

FEASIBILITY OF UNDERGROUND FREIGHT TRANSPORTATION (UFT) IN TEXAS

By

SEYEDEH HOSNA MOUSAVIPOUR

Presented to the Faculty of the Graduate School of
The University of Texas at Arlington in Partial Fulfillment
of the Requirements
for the Degree of

MASTER OF SCIENCE IN CIVIL ENGINEERING

THE UNIVERSITY OF TEXAS AT ARLINGTON

December 2015

Copyright © by Seyedeh Hosna Mousavipour 2015

All Rights Reserved



Acknowledgements

Foremost, I would like to express my sincere gratitude to my advisor, Dr. Mohammad Najafi, for his continuous support of master's degree study and research, for his patience, motivation, enthusiasm, and immense knowledge. His guidance helped me immeasurably while researching and writing this thesis. I could not imagine having a better advisor and mentor. In addition to my advisor, I would like to thank the rest of my thesis committee, Dr. Yu and Dr. Sattler for their encouragements, insightful comments, and questions.

I would like to thank my friends for helping me get through the difficult times and for all their support, entertainment, and caring. Without them, this research would have been impossible.

I would like to thank Mr. Jim Rush, Editor of Trenchless Technology Magazine, who assisted with the survey and provided valuable information.

Additionally, I would like to thank all the survey respondents for their time and efforts to provide valuable information regarding the feasibility of underground freight transportation in Texas.

Finally, I would like to thank my parents and family for their endless love and encouragement throughout the course of my study at The University of Texas at Arlington. To them I dedicate this thesis.

November 23, 2015

Abstract

Feasibility of Underground Freight Transportation (UFT) in Texas

Seyedeh Hosna Mousavipour, MS

The University of Texas at Arlington, 2015

Supervising Professor: Mohammad Najafi

The U.S. economy is expected to double in size over the next 30 years. Truck and rail freight traffic is expected to increase by approximately 45 percent. Air freight is expected to triple in response to demand for the rapid movement of high-value merchandise, while multimodal shipments will likely double.

Texas with a gross state product (GSP) of \$1.4 trillion dollars is the second largest economy in the U.S. Its size and population, central location, Gulf coastline, and energy resources require a reliable freight transportation system to facilitate further growth. This thesis focuses on the feasibility of Underground Freight Transportation (UFT) to determine the role of UFT in addressing the growing demand for freight transportation in Texas.

Underground Freight Transportation (UFT) is a process in which freight is transported in large capsules moving through underground pipelines. As concluded in this thesis, UFT reduces congestion and traffic jams on highways and streets, and increases highway safety by reducing the number of accidents caused by freight trucks, and also reduces highways maintenance costs.

To conduct this research, in addition to a comprehensive literature search, a survey on the feasibility of Underground Freight Transportation was performed. The

survey was sent to the professionals involved in design, engineering, planning, contracting and regulating freight transportation in the state of Texas.

The results of this investigation showed that, due to expected increase in freight transportation in the next couple of decades, UFT can be used as a complementary method of freight transportation to reduce the increased traffic load caused by freight trucks on the road structure.

Table of Contents

Acknowledgements	iii
Abstract	iv
List of Illustrations	x
List of Tables	xii
Chapter 1 Introduction.....	1
1.1 Background.....	1
1.3 Objectives	3
1.4 Need Statement.....	3
1.4.1 Freight Traffic	4
1.4.2 Panama Canal Expansion.....	5
1.4.3 Population Growth.....	6
1.4.4 Air Cargo Transportation in Texas	8
1.5 Methodology	11
1.6 Expected Results.....	12
1.7 Chapter Summary.....	13
Chapter 2 Literature Review	14
2.1 Background.....	14
2.1.1 Automated Trucks	15
2.1.2 Rail- Bound Vehicles	15
2.1.3 Coal Slurry Pipelines	15
2.1.4 Pneumatic Capsule Pipeline (PCP).....	16
2.1.5 Linear Induction Motor (LIM)	17
2.1.6 Hydraulic Capsule Pipeline (HCP)	18
2.2 Previous Studies.....	18

2.3 UFT Components	24
2.3.1 Capsules.....	24
2.3.2 Rails.....	24
2.3.3 Station	24
2.3.4 Control System	26
2.4 Underground Infrastructure (Tunnels)	26
2.4.1 Feasibility Study	27
2.4.2 Planning and Design	27
2.4.3 Construction	28
2.4.4 Commissioning.....	28
2.5 Construction Cost and Variables	28
2.5.1 Geotechnical Risks.....	29
2.5.2 Location	29
2.5.3 Design	30
2.5.4 Safety Regulations	30
2.5.5 Environmental Regulations	31
2.5.6 Contingencies.....	31
2.5.7 Material/Labor.....	31
2.6 Tunnel Construction Methods.....	32
2.6.1 Tunnel Boring Machine (TBM)	32
2.6.2 Cut-and-cover.....	34
2.7 Chapter Summary.....	35
Chapter 3 Case Study.....	36
3.1 Background.....	36
3.2 Methodology	36

3.2.1 Technology Description.....	36
3.2.2 Potential Applications to New York City	37
3.2.2.1 Tunnel Construction.....	37
3.2.2.2 Transporting Pelleted and Other Goods (Pallet-Tube System)	38
3.2.2.3 Solid Waste Transport	39
3.2.3 Routes	39
3.3 Cost Analysis.....	40
3.4 Case Study Conclusions	41
3.5 Chapter Summary.....	42
Chapter 4 Survey on Feasibility of Underground Freight Transportation (UFT)	
in Texas.....	43
4.1 Introduction.....	43
4.2 Methodology	43
4.3 Objectives.....	44
4.4 Questionnaire and Results	44
4.5 Analysis of Results	60
4.6 Chapter Summery.....	60
Chapter 5 Discussion of Results.....	61
5.1 Introduction.....	61
5.2 Results of Literature Review.....	61
5.3 Results of Survey.....	64
5.4 Chapter Summery.....	66
Chapter 6 Conclusions and Recommendations for Future Research	67
6.1 Conclusions	67
6.2 Recommendations for Future Research	68

Appendix A List of Acronyms and Abbreviations	69
Appendix B Survey Questions	71
References	78
Biographical Information	83

List of Illustrations

Figure 1.1 Modes of Transportation Distribution.....	2
Figure 1.2 U.S. Ton-Miles of Freight (in Millions)	2
Figure 1.3 Cost of Congestion	4
Figure 1.4 Top 10 U.S. Ports in 2014 by Cargo Value	5
Figure 1.5 Population Change Projections by Commuting Zone, 2010-2030 Source: Foxx, 2015	7
Figure 1.6 Population Change Projections Source: Texas Freight Advisory Committee, 2015	7
Figure 1.7 Research Methodology Flowchart	12
Figure 2.1 UFT Methods	14
Figure 2.2 PCP (Source: Kosugi, 2000).....	17
Figure 2.3 CargoCap (Source: www.cargocap.com)	20
Figure 2.4 FSS (Source: Roop et al, 2011).....	22
Figure 2.5 GRID System (Source: http://www.gridinc.biz/thegridproject).....	23
Figure 2.6 Railroad with required two switchblades	24
Figure 2.7 UFT tunnels with stations	25
Figure 2.8 Capsule exit/entrance ramp.....	25
Figure 2.9 Tunnel Delivery Process Source: Erfon and Read, 2012.....	27
Figure 2.10 Tunnel Boring Machine.....	32
Figure 3.1 Pneumatic Capsule Pipeline (a) shows a Round PCP and (b) is a.....	37
Figure 3.2 Tunnel entrance.....	38
Figure 3.3 PCP extending outside the tunnel to the dump site	38
Figure 3.4 Cross-section of the pallet-tube PCP for New York City	39
Figure 3.5 Proposed alternative PCP routes (AB and CD) investigated	40

Figure 4.1 Respondents Involvement with Freight Transportation	45
Figure 4.2 Distribution of Respondents Involvement with Freight Transportation	46
Figure 4.3 Cost Effectiveness of UFT	48
Figure 4.4 UFT Expected Construction Date	49
Figure 4.5 Applicable Construction Methods of UFT	50
Figure 4.6 UFT Challenges	52
Figure 4.7 UFT Construction Obstacles	53
Figure 4.8 Applicable UFT Sizes	54
Figure 4.9 Applicable UFT Sizes for Proposed Routes	55
Figure 4.10 Benefits of UFT	57
Figure 4.11 Applicable Financing Methods	58
Figure 4.12 Applicable Delivery Methods	59

List of Tables

Table 1.1 DFW Air Cargo, 1996–2007 (tons)	9
Table 1.2 Top 11 Texas Airports by Total Air-Cargo Activity, 2007 (tons)	10
Table 4.1 Respondents Involvement with Freight Transportation	45
Table 4.2 Distribution of Respondents Involvement with Freight Transportation	46
Table 4.3 Cost Effectiveness of UFT	48
Table 4.4 UFT Expected Construction Date	49
Table 4.5 Applicable Construction Methods of UFT	51
Table 4.6 UFT Challenges	52
Table 4.7 UFT Construction Obstacles.....	53
Table 4.8 Applicable UFT Sizes.....	54
Table 4.9 Applicable UFT Sizes for Proposed Routes	56
Table 4.10 Benefits of UFT	57
Table 4.11 Applicable Financing Methods.....	58
Table 4.12 Applicable Delivery Methods.....	60

Chapter 1

Introduction

1.1 Background

The purpose of this thesis is to investigate the feasibility of Underground Freight Transportation in Texas and to study the potentials for employing technological advances in Underground Freight Transportation (UFT), which allows for the efficient use of available highway capacity. With increasing traffic in the current highway system in both freight transportation and human movement, many of the nation's roads are getting congested and continue to worsen due to a population increase in the U.S. and State of Texas (Texas Freight Advisory Committee, 2015).

Approximately 63 tons of goods per person in the U.S. are moved by trucks, railroad, waterborne and air transportation methods each year. As our population grows and our economy expands, demand for freight transportation will grow as well, thereby straining an already challenged system (Foxy, 2015).

The U.S. economy is expected to double in size over the next 30 years. Truck and rail freight movements are expected to increase by approximately 45 percent. Air freight is expected to triple in response to demand for the rapid movement of high-value merchandise, and multimodal shipments are expected double. Overall, the volume of imports and exports transported by our freight system is expected to more than double in the next 30 years. This expansion of imported goods will have implications for ports, which handle 75 percent of America's international trade by volume, and for intermodal carriers that move imports and exports between ports and inland locations (Foxy, 2015). Figure 1.1 illustrates different modes of transportation. Figure 1.2 shows how ton-miles of the trucking industry has more than doubled between 1980 and 2011.

Every mode of transportation moves freight, but trucking is the primary mode of freight travel.



Figure 1.1 Modes of Transportation Distribution
Source: Foxx, 2015

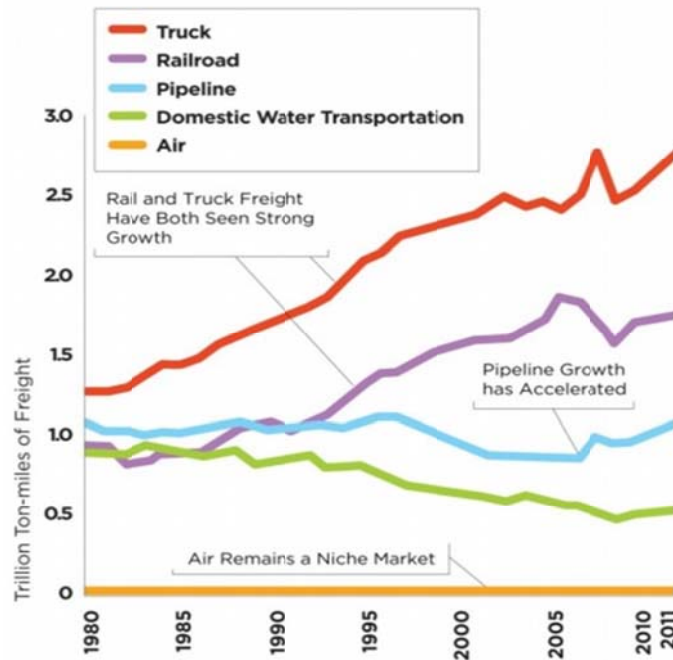

Figure 1.2 U.S. Ton-Miles of Freight (in Millions)
Source: Foxx, 2015

Additionally, Figure 1.2 shows the ton-miles quantity of U.S. freight transported in the last 30 years. As shown, trucks are the main means of freight transportation in the U.S followed by railroad.

Based on the 2014 Texas Motor Crash Statistics published by Texas Department of Transportation, in Tarrant and Dallas Counties alone, more than 5,000 commercial

motor vehicle crashes were reported that year. The same report estimated that the economic loss of all motor vehicle crashes in Texas in 2014 was \$28.8 billion compared to \$20.7 billion in 2003. This economic loss can potentially be reduced by separating freight transportation from human transportation on highways. UFT can increase highway safety by reducing the volume of trucks on highways (Texas Freight Advisory Committee, 2015).

In 1924, at the 1st National Conference on Streets and Highways Safety in Washington D.C., it was determined that the separation of freight transportation from human movement could increase efficiency and safety (Foxy, 2015). Since then, the idea of separation of freight and human movement has been periodically reexamined.

Underground transportation systems have many desirable features such as less environmental impacts. These systems can be fully automated. Last but not least, they are enclosed in an underground capsule that can be operated regardless of weather or conditions above ground (Liu, 2004).

1.3 Objectives

The main objectives of this thesis are:

- To analyze feasibility of underground freight transportation in the State of Texas
- To identify features and benefits of underground freight transportation as well as its limitations compared with other modes of transportation in Texas

1.4 Need Statement

Based on the previous section, in the next 30 years, an expected expansion in both the U.S. economy and population will increase transportation of goods. The following sections present growth impacts on the U.S. transportation system and

additional information on the effect of the projected increase in traffic congestion on Texas freight delivery.

1.4.1 Freight Traffic

Growth in overall freight demand will increase freight congestion and delays throughout the country. In 2012, approximately 10 million trucks moved more than 13 billion tons of freight across America's highways. These trucks are major contributors to congestion on 4,500 of the busiest highway miles in the nation (Foxx, 2015).

Based on a report prepared by U.S. Department of Transportation, areas with the worst truck delays include major international trade gateways and hubs, such as Los Angeles, New York, and Chicago, and major distribution centers such as Atlanta, Charlotte, Dallas-Fort Worth, Denver, Columbus (Ohio), and Portland (Oregon). Border crossings are also bottlenecks. At two major Mexican border crossings, it takes trucks, on average, nearly an hour to enter the United States (Foxx, 2015). Figure 1.3 presents amount of money which will be spent on traffic congestion in 2040.



Figure 1.3 Cost of Congestion
Source: Foxx, 2015

Figure 1.4 shows the largest ports used for import and export purposes in the U.S., and presents Houston, Texas as the third largest port in the U.S. based on its delivery of \$168.3 billion worth of imported and exported containerized freight annually.



Figure 1.4 Top 10 U.S. Ports in 2014 by Cargo Value
 Source: Foxx, 2015

1.4.2 Panama Canal Expansion

The Panama Canal, completed in 1914, created one of the most important trade routes in the world, linking the Atlantic and Pacific Oceans. After nearly a century, the canal is undergoing a \$5.25 billion dollar expansion to accommodate more and larger ships. When the expanded canal opens in 2015, the new locks will allow for deeper, longer and wider 'New Panamax' vessels, essentially doubling existing throughput capacity. The expansion will reduce Canal delays, and potentially reduce shipper costs (Cambridge Systematics, Inc., 2011).

The widening and deepening of the Panama Canal, which is expected to be completed by 2016, will enable larger ocean-going vessels, to be referred to as "Post-

Panamax” ships, to pass through the Canal. Of the cargo passing through the Canal, 64 percent originates in or is destined for the United States, so the widening is expected to increase the containerized ship freight volume loaded and unloaded at Gulf and East Coast ports. Canal improvements may also increase traffic at West Coast ports by enabling more efficient commerce between those ports and the Caribbean, as well as Atlantic ports in South America. It will also become increasingly important for ports to address congestion and equipment shortage challenges generated by bigger, new-generation container ships that offload larger volumes of containers in relatively shorter amounts of time (Cambridge Systematics, Inc., 2011).

The Panama Canal Authority (ACP) estimated that with expansion, total volumes transiting the Canal would increase from a total of 279 million tons in 2005 to 508 million tons in 2025, a 3 percent annual growth rate (Cambridge Systematics, Inc., 2011). If this growth is evenly distributed, Texas ports can expect to receive an additional 6.6 million tons of cargo arriving from the Pacific via the Canal, and to export an additional 15 million to destinations in the Pacific (Cambridge Systematics, Inc., 2011).

1.4.3 Population Growth

Freight is a demand driven activity. Population growth leads to more consumption of goods, commodities and services which increases freight activity. Figures 1.5 and 1.6 show the projected percent change in the population between 2010 and 2040 in United States and in Texas respectively. Figure 1.5 shows significant population increase in Austin, San Antonio, Houston and DFW area. This population increase results in freight transportation increase demand (Foxy, 2015).

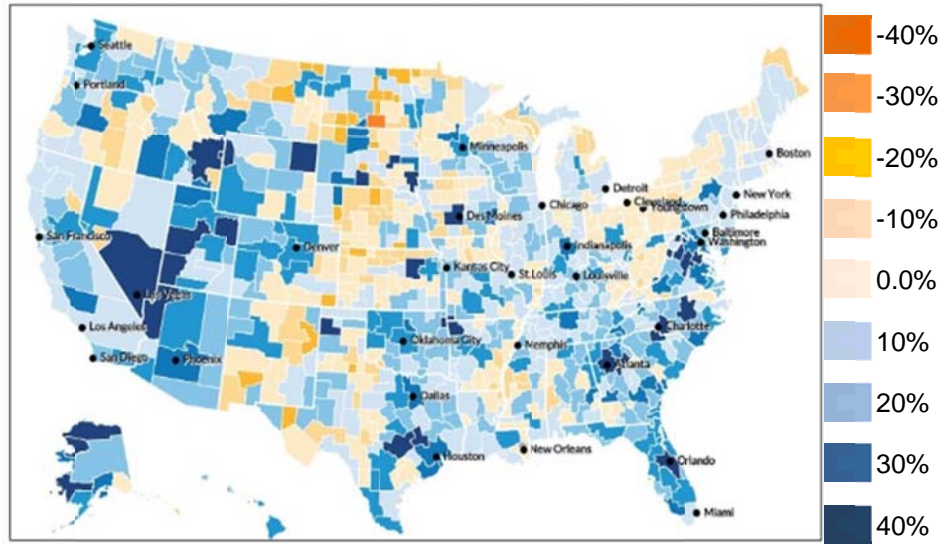

Figure 1.5 Population Change Projections by Commuting Zone, 2010-2030
Source: Foxx, 2015

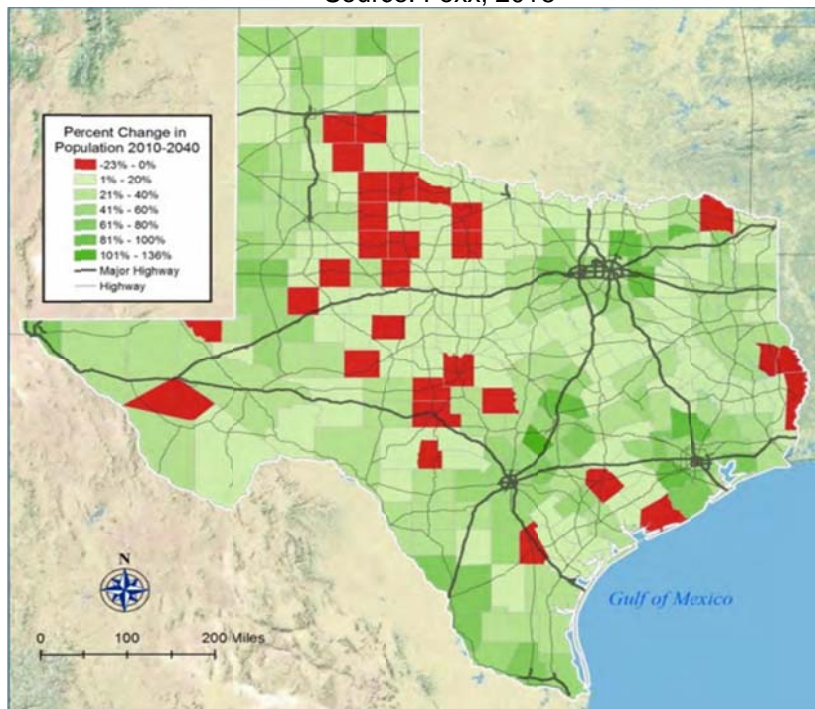

Figure 1.6 Population Change Projections
Source: Texas Freight Advisory Committee, 2015

Currently, heavy-duty long-haul semi-trucks use the existing roadways to transport and distribute goods to the desired locations. However, this type of delivery service comes at a high cost, which includes road and bridge deterioration, congestion, traffic safety issues, and pollution. The funding for state transportation departments, which is supplemented by fuel taxation and the highway trust fund, is showing signs of distress. State departments of transportation are struggling with the overwhelming burden of highway expansion to meet growing demand while maintaining the aging network that is already in place. According to the ASCE report card for 2013, the condition of US roads rates a grade of D. Their overview summary is as follows (ASCE, 2015):

“Forty-two percent of America’s major urban highways remain congested, costing the economy an estimated \$101 billion in wasted time and fuel annually. While the conditions have improved in the near term, and Federal, state, and local capital investments increased to \$91 billion annually, that level of investment is insufficient and still projected to result in a decline in conditions and performance in the long term. Currently, the Federal Highway Administration estimates that \$170 billion in capital investment would be needed on an annual basis to significantly improve conditions and performance” (ASCE 2015).

This same report noted that our road network contains 4 million miles of public roadways for almost 3 trillion vehicle miles as per 2011 statistics. Nearly 11 million trucks travel these roads.

1.4.4 Air Cargo Transportation in Texas

Texas airports play a significant role in the movement of goods by air. Most of this movement of goods is accomplished at the largest airports in Texas. Hence, the Dallas/ Fort Worth International Airport (DFW) and Houston Intercontinental Airport rank highly among all U.S. airports in terms of freight value and weight (Frawley et al., 2011).

Between 1996 and 2006, growth in air-cargo activity at DFW has been steady, averaging almost 12 percent over the 11-year period (see Table 1.1). Table 1.1 also shows an increase in activity of 46 percent between 2000 and 2001, due in large part to the establishment of the UPS Airlines operations hub at DFW in 2001. In 2007, the Dallas/Fort Worth International Airport (DFW) was the most dominant Texas airport in terms of total tons of cargo activity, accounting for 41.53 percent of all air-cargo movements in the state (see Table 1.2) (Frawley et al., 2011).

Table 1.1 DFW Air Cargo, 1996–2007 (tons)
Source: Frawley et al., 2011

Year	Inbound	Outbound	Total
1996	188,226.06	196,132.49	384,358.55
1997	194,799.84	199,306.71	394,106.55
1998	186,645.35	191,051.17	377,696.52
1999	197,573.25	190,982.03	388,555.29
2000	216,402.83	199,691.29	416,094.11
2001	316,652.79	290,129.53	606,782.32
2002	325,006.28	286,628.37	611,634.65
2003	433,580.24	377,384.42	810,964.66
2004	485,381.67	406,400.25	891,781.93
2005	473,005.84	399,615.20	872,671.05
2006	481,322.45	408,279.78	889,602.23
2007	468,527.60	382,221.93	850,749.53

In 2007, the airport experienced a decrease in drop-off business between the DFW international airport and the temporary distribution stations. However, the air cargo business increased every year up until 2007. In 2008, DFW added air cargo service to Japan and DFW's main air cargo service, has maintained an impressive growth rate of more than 18 percent annually since 2000 (DFW Newsletter, 2008).

Table 1.2 Top 11 Texas Airports by Total Air-Cargo Activity, 2007 (tons)
Source: Frawley et al., 2011

Rank	Code	City	Inbound	Outbound	Total	parcel
1	DFW	Dallas/Fort Worth International	468,527.60	382,221.93	850,749.53	41.53
2	IAH	Houston International	231,731.54	248,075.75	479,807.29	23.42
3	AFW	Fort Worth Alliance	107,993.32	115,504.63	223,497.95	10.91
4	SAT	San Antonio International	87,773.71	59,605.44	147,379.15	7.19
5	AUS	Austin-Bergstrom International	57,199.80	55,826.76	113,026.56	5.52
6	ELP	El Paso International	41,538.93	44,231.39	85,770.32	4.19
7	HERL	Rio Grande Valley International	18,710.92	17,371.47	36,082.39	1.76
8	DAL	Dallas Love Field	15,940.32	14,900.82	30,841.15	1.51
9	LBB	Lubbock International	19,499.44	8,605.77	28,105.21	1.37
10	LRD	Laredo International	17,804.87	9,265.44	27,070.31	1.32
11	HOU	Houston Hobby	6,987.19	9,296.11	16,283.30	0.79
Remainder of Texas			5,690.29	4,421.30	10,111.59	0.49
Total Texas Activity			1,079,397.93	969,326.82	2,048,724.75	100

As discussed previously, Texas is one of the major states in the United States with problems associated with traditional freight transportation. A potential solution to these problems may be Underground Freight Transportation. To address this problem,

four routes were considered in this thesis to study the feasibility of underground freight transportation in Texas:

- Port of Houston to a Distribution Center in Dallas
- The border with Mexico at Laredo to a Distribution Center in Houston
- Port of Houston to a Distribution Center Outside of Houston
- DFW airport to a distribution center within 10 miles

1.5 Methodology

- Perform literature research and analysis of case studies. Research sources included:
 - Relevant manuals, books, and reports, using both online research and research at UTA libraries.
 - Academic database sources such as Engineering Village, Science Direct, and theses and dissertations from UTA as well as other universities.
 - Relevant industry-based technical papers and journal databases such as ProQuest, Engineering Village, and ASCE.
 - Other relevant publically available journal and magazine databases such as those found in *Underground Construction* and *Trenchless Technology*.
 - A survey of area engineers, educators, government entities and their agency personnel, and contractors.
 - All of these resources will be used to identify features and benefits of underground freight transportation as well as its limitations. The findings will be incorporated into the thesis as shown in Figure 1.7, which represents a flow chart of the organization of this thesis.

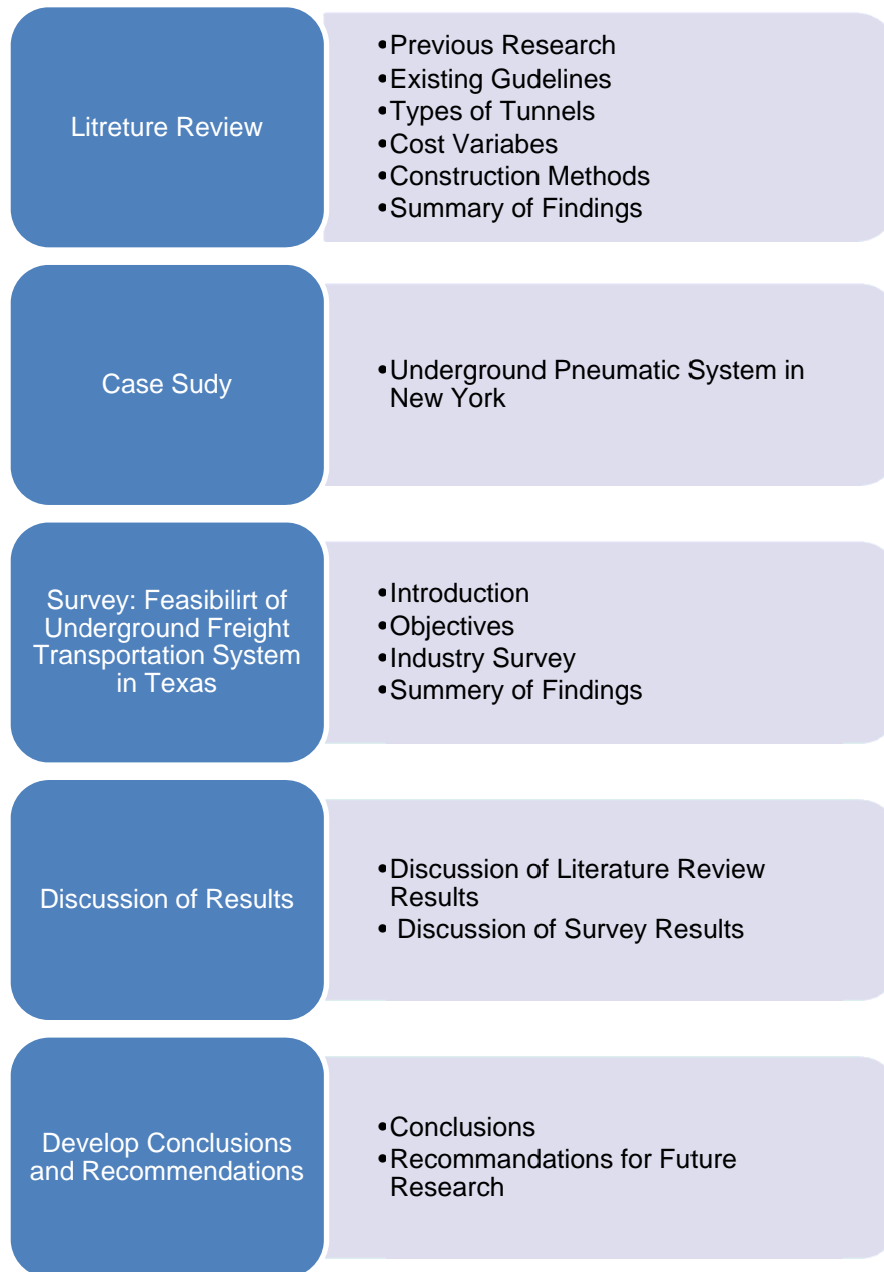

Figure 1.7 Research Methodology Flowchart

1.6 Expected Results

The demands for freight transportation will increase due to significant expected population increase in the state of Texas in the next few decades. The increase in truck

freight transportation will cause traffic congestion on highways and also requires massive investments in construction and maintenance of highways. Underground freight transportation is expected to be used in the next few decades to address part of freight transportation needs in the future. It is expected that UFT can be used as a part of intermodal freight transportation in the State of Texas. However, considering the technological, financial and constructability limitations, UFT is not likely to become the main mode of freight transportation in the U.S. for at least 20 years.

1.7 Chapter Summary

This chapter presented existing conditions of freight transportation as it relates to a potential for a new mode of transportation (e.g., pneumatic underground freight transport) as well as expected demand increase in the next few decades for freight transportation in the U.S. and State of Texas. Finally, the objectives and expected outcome of this thesis were presented.

Chapter 2

Literature Review

2.1 Background

“Underground Freight Transportation (UFT) includes all the methods of automated transport of general cargo by vehicles moving through a network of underground tunnels” (Roop et al., 2000). UFT has been in operation for 150 years and can be categorized as capsule pipeline systems and automated vehicle systems. In the capsule pipeline system, freight is transported in a capsule through underground pipeline large enough to accommodate the semi-trailer loads being delivered by the semi-trucks often referred to as 18-wheelers. Automated vehicle systems transport freight using automated vehicles through a tunnel (Pielage and Rijsenbrij, 2005).

Different types of Underground Freight Transportation Systems can be found in Figure 2.1.

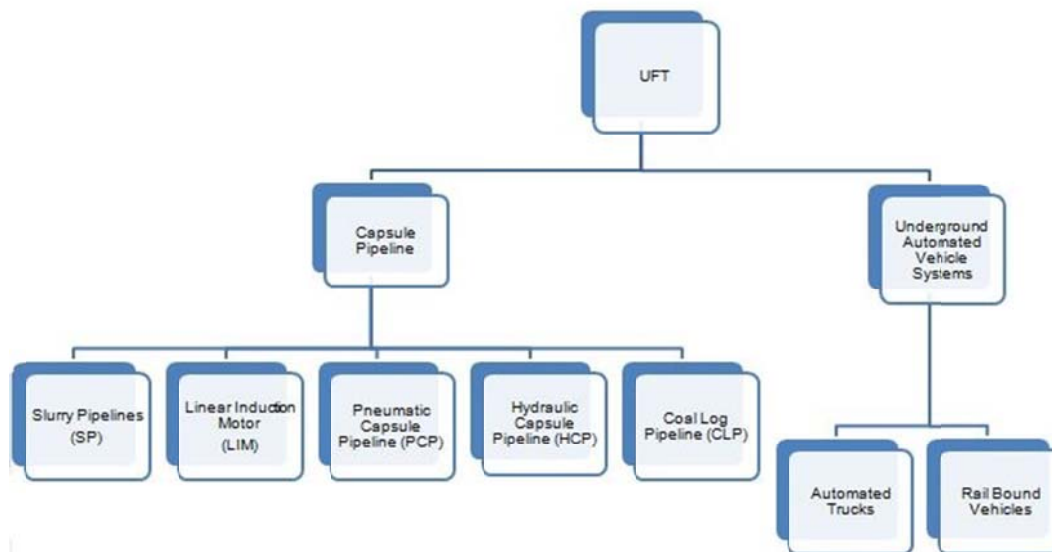

Figure 2.1 UFT Methods

Automated vehicles can operate underground without any disturbance on the surface, which leads to a more reliable and efficient transportation system. Automated vehicle systems can be categorized as follows:

2.1.1 Automated Trucks

Trucks are one of the most important vehicles for goods movement. “One of the developments of automated vehicle systems was involving the automation of small trucks underground” (Pielage and Rijsenbrij, 2005). In Japan the Public Works Research Institute (PWRI) in 1980, started research on Underground Freight Transportation and automated trucks. This automated transportation system could travel through underground tunnels without a driver. The electric vehicle used side wheels and had an external power supply while traveling on an exclusive track (Pielage and Rijsenbrij, 2005).

2.1.2 Rail- Bound Vehicles

Since the invention of the first rail system, there have been some developments in rail bound systems. In Japan, much research was conducted in the 1990s on the possibility of Underground Freight Transportation systems with rail bound vehicles driven by linear motors. The Tokyo L-net project, for instance, proposed an underground network for trains with linear motors to connect post offices in the central area of Tokyo (Pielage and Rijsenbrij, 2005).

Freight pipelines can be divided in to four groups: Coal Slurry Pipelines, Pneumatic Capsule Pipeline (PCP), Linear Induction Motor (LIM), and Hydraulic Capsule Pipeline (HCP). These terms are defined as follows:

2.1.3 Coal Slurry Pipelines

Coal pipelines are usually referred to as slurry pipelines because coal is moved in a pulverized form in water (one-to-one ratio by weight). Once coal arrive its destination,

water is removed and the coal is ready for use. Slurry lines are primarily used for transporting coal to utility companies for generating electricity (Roop et al, 2000).

2.1.4 Pneumatic Capsule Pipeline (PCP)

In the PCP system blowers or fans are used to move the capsule which leads to blocking the tube for passage of other capsules. A complicated switching system as switching pipes are used to make capsules bypass the blowers. In this system, the flow is not continuous and it becomes severely limited. They greatly reduce the efficiency of PCP systems, which make it impractical to use PCP for long distances and in complex tube systems where the flow must be continuous, where capsules must be able to enter and leave tubes at intermediate stations, and where the PCP have multiple inlets/outlets or branches (Liu, 2004). Despite these disadvantages, there was one PCP at the Karasawa Mine of Sumitomo Cement Company in Kuzuu-City, Japan that used PCP for transporting limestone at a rate of 2 million tons per year between a mine and a cement plant. The distance was 3200 meters and it achieved continuous loading and unloading with a controlled velocity and the aid of a braking zone. Sumitomo began researching PCP in 1974 and with the help of Kajima Corporation; his Sumitomo Metals introduced a newly developed PCP in 1983 and put it to work transporting limestone.

Figure 2.2 shows Sumitomo's PCP system in a tube. The illustration was created by Sanai Sumitomo and used extensively by Dr. Liu (with permission) to create interest in the technology. The illustration is actually highlighting the wheels. Sumitomo used wheeled capsules in his PCP to transport limestone for about 20 years. Each wheel set was made up of at least five small wheels placed at each end of the capsule. Sumitomo's system connected three capsules together to make one capsule train. The wheel assemblies were mounted on a bearing at the central axis of the capsule. The cargo remained stable because the capsule's center of gravity was below the point of rotation,

thereby preventing spillage. Meanwhile, the wheel assemblies were set at a slight angle to allow them to spiral in transit which allowed an even distribution tire wear. One of the unique aspects of Sumitomo's system was that while the capsule were in motion the three bottom lids of each capsule would open and close consecutively to unload the limestone. Furthermore, both ends of the pipelines were fitted with dual blowers to minimize the effect of rapid pressure increase when the capsule train increased speed in the launching tube. A centrifugal suction blower pulled the train into the tube (Kosugi, 1992).

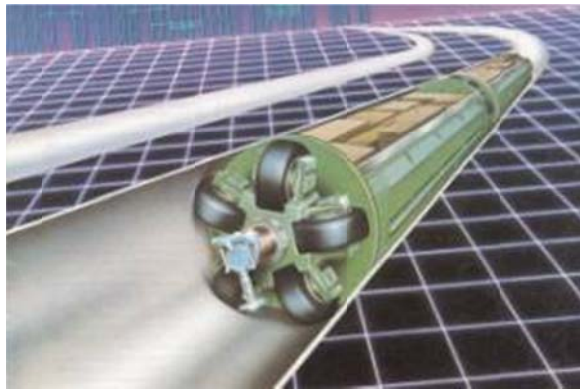

Figure 2.2 PCP (Source: Kosugi, 2000)

2.1.5 Linear Induction Motor (LIM)

In 2000, Liu was looking at the linear induction motor (LIM) as a non-intrusive type of pump instead of blowers. He also stated that loading and unloading of capsules should be done outside the pipeline. He was confident that if these improvements were added, a fivefold increase in the line fill of PCP from the current 3% to 15% was possible. Liu's solution to the pump problem was an electromagnetic capsule pump, i.e., the linear induction motor (LIM) (Liu, 2000). Unfortunately, his life was cut short before he could build a prototype and prove the viability of such a system.

As Liu stated at the first international symposium on underground freight pipelines, the problems associated with PCP can be solved by using the linear induction motor (LIM). In this system instead of using blowers capsules are pumped by the electromagnetic capsule pump, i.e., the LIM. The following is copied from Liu's 2000 Mid-Continent Transportation Symposium article:

“As capsules of metallic wall enter the LIM, an electromagnetic thrust is generated on the capsules to accelerate and to push the fluid forward. The capsule wall will be made of steel with an outer layer of aluminum. An “eddy current” is induced in the aluminum wall which generates the electromagnetic force (thrust) needed to push the capsules forward” (Liu, 2000).

2.1.6 Hydraulic Capsule Pipeline (HCP)

Hydraulic Capsule Pipeline (HCP) was first introduced during World War II to transport war materials to China via Burma. Due to technological constraints at that time, the concept was never implemented. The concept was reborn in Canada in 1959 and has been studied in the U.S., Japan, and South Africa since then. HCP uses water as a transporting fluid. Since water is a thousand times denser than air at standard atmospheric pressure, larger buoyancy and lift forces are generated on hydraulic capsules, thus making it possible to lift the capsules in the pipe at relatively low velocities without the need for wheels (Roop et al, 2000).

2.2 Previous Studies

A conceptual research project by Visser and Binsbergen focused on urban freight transport as an element in larger transportation and distribution systems for the daily delivery of goods. The study included transportation systems with a linear motor with pneumatically or electrically driven self-propelled transporting units for the city of Leiden in The Netherlands. Major areas in this study included receiving the goods, transporting

the goods, delivering the goods, and the control system. Due to technical limitations in pneumatic systems like loss of compressed air and steering issues, was considered not feasible for (Visser and Binsbergen, 1997).

In 1998, Goff et al. studied the feasibility of a freight pipeline structure between San Antonio and Dallas, (approximately 300 miles long). The diameter of the pipeline was assumed to be 6.6 ft. Proposed terminals for the system were to be located at Waco, Temple, Austin, and San Marcos, in addition to the end terminals. Assuming LIM as the means of propulsion, capsules would travel at 55 mph. Based on this research it was estimated that the mean years to failure for the propulsion and control systems are 80 years which is approximately eight times more effective (indicating more years of use) than the average of 10 years estimated for truck engine failure. The total life time of the tube system itself was estimated to 60 years until failure, which is approximately three times greater than highway and finally, the track or guide way would last approximately 55 years until failure (Goff et al, 1998).

CargoCap is a project which was initiated in 1999 at the Ruhr University, Bochum. The aim was to develop an underground freight transportation system in the Ruhr area to connect urban areas, industrial estates, business centers, logistic parks, airports etc. The inner diameter of the proposed CargoCap capsule, as shown in Figure 2.3, is 63 in. and the vehicles can carry two Euro Pallets ($W*L*H = 32*48*42$ in.) run on rails.



Figure 2.3 CargoCap (Source: www.cargocap.com)

Vehicles travel at 20 miles/hour with a minimum spacing of 6.6 ft between each vehicle. The CargoCap plan is to develop the system in several stages, starting with basic components and scaled prototypes, eventually arriving at an operational system for the Ruhr area. Possible extensions into the Rhineland are also for seen (Pielage and Rijsenbrij, 2005). Figure 2.3 shows a CargoCap capsule with the two Euro Pallets. According to Lavagno and Schranz (2008), CargoCap is capable of carrying 2/3 of the goods that are being transported in Germany.

A UFT feasibility study for use on highway M25, London, UK, was conducted by Miles and Loose for Mole Inc. in 2008. This highway's congestion is due to an overload of passenger car and truck traffic. It is also close to an airport, which adds to the problem. The best solution could be the separation of freight transportation and human movement. In this research, Miles and Loose studied how the new technology would affect direct cost and capital cost as well as the potential social and environmental benefits (Miles and Loose, 2008).

Based on the Miles and Loose (2008) study, by using underground freight pipelines, travel time would be reduced by up to 5% which is equal to an estimated \$4 billion in cost savings. In addition, based on estimated costs in the UK, the trunk road building cost million dollars per miles however, the cost of one mile of underground freight pipeline depends on the amount of cut and fill and boring which is approximately \$3 million per mile (Miles and Loose, 2008).

Based on 2005 statistics in the UK, Heavy Goods Vehicle (HGV) caused 486 accidents and 3200 serious injuries while carrying 63% of UK's freight; however; oil pipelines carried 4% of the freight with no injuries. Last but not least, underground freight pipelines would be generated by electricity, which can be fed from a renewable source. Hence, the air pollution is much less than trucks. Additionally, trucks have high visual impact and produce noise pollutants. Nevertheless, Miles and Loose (2008) predicted that all these negative impacts would be reduced by an underground transportation system.

Roop et al. (2011) addressed freight transportation problems in the ports-of-entry (POE) along the border of Mexico from El Paso to Ciudad Juarez. Generally, this region faces a lot of truck traffic that is either importing or exporting goods, and it is estimated each truck spends about one hour in traffic peak (most conducive to congestion) on average. One of the issues which leads to this problem is establishing manufactures in this area since Mexico is the closest market and the cheapest resource. All of these problems contribute to more freight traffic which causes significant amount of pollution, increasing diesel consumption, and more delay in freight delivery. In addition a considerably high amount of drug traffic threatens the security of freight transportation. In order to solve these problems, an alternative transportation system, the Freight Shuttle System (FSS), has been suggested (Roop et al, 2011). Figure 2.4 shows FSS.



Figure 2.4 FSS (Source: Roop et al, 2011)

In order to analyze the feasibility of FSS via trucks and highways, a statistical study covering a projected 24-year period was conducted. One of the focus areas of this study was the improvement of air quality. Since FSS is an electronically operated transportation system, and green energy such as solar or wind can generate the necessary power, in a 24-year period 87,000 tons of pollutants and 696 tons of NO_x could be prevented from entering the atmosphere (Roop et al, 2011). In addition to air quality, FSS plays a significant role on diesel consumption. Over the 24-year period, FSS can reduce 47.9 million vehicle miles traveled (VMT) which leads to cutting diesel fuel consumption by up to 7.5 million gallons (Roop et al, 2011). By analyzing truck delay times, it has been concluded that FSS in a 24 year period eliminates 3.1 million hours of delay. Considering the value of time for trucking at \$76.29 per hour, the calculated Net Present Value (NPV) for avoided delay is \$102 million (Roop et al, 2011). Last but not least, to enhance Customs and Border Protection (CBP) a method called Inspect-in-Motion has been suggested to utilize FSS to inspect 100 percent of the cargoes (Roop et al, 2011).

Another UFT study is based on Southern California geography and logistics, which is known as the GRID System and is exportable and scalable to meet local geographic, geologic, environmental, and logistic needs.

The objectives of this study were to reduce the amount off truck traffic, which delivers the cargoes between terminals in Southern California Harbor to the distribution centers. The freight pipeline is 137 miles long and is designed to follow current logistics routes 60 feet below that can coincide with the surface transportation routes. Powered by electric rail and transported by drone train technologies, it will operate out of sight and out of mind to deliver cargo to our inland feeder distribution terminals. This pipeline system is specifically designed to replace a large portion of truck drayage coming to and from port complexes. This system will significantly reduce time and increase the productivity of delivering the cargoes up to 90%. This includes servicing inter-state deliveries as well as the electric drone trains feeding into our freight pipeline. Figure 2.5 presents the conceptual freight pipeline system in California (GRID Logistic Corporation, 2015).

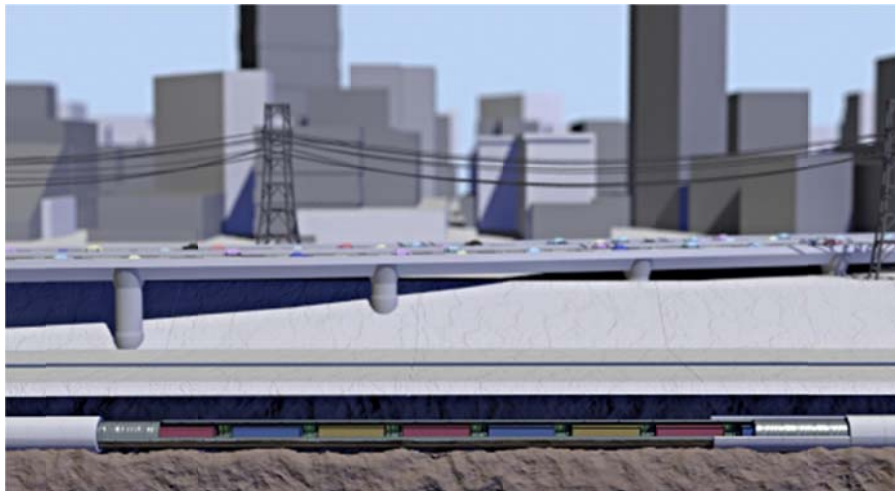

Figure 2.5 GRID System (Source: <http://www.gridinc.biz/thegridproject>)

2.3 UFT Components

Underground Freight Transportation components can be found as follow.

2.3.1 Capsules

The capsules consist a box which carries the cargo. The box usually includes wheels and a battery pack to power the capsule when it is the self-propelled (e.g., LIM). These batteries are a special type of lithium battery that can be rapidly charged and have a high cycle life. Currently, such batteries are used in electric and hybrid vehicles. The capsule can travel approximately 100 miles on a single charge (Liu and Lenau, 2008).

2.3.2 Rails

It has been determined that in order to have the most productive transportation system, a well-designed railroad must have a smart switching system. Figure 2.6, represents a railroad with the required two switchblades. In this system two switchblades work together which leads the capsule to drive into the right rail (Liu and Lenau, 2008).

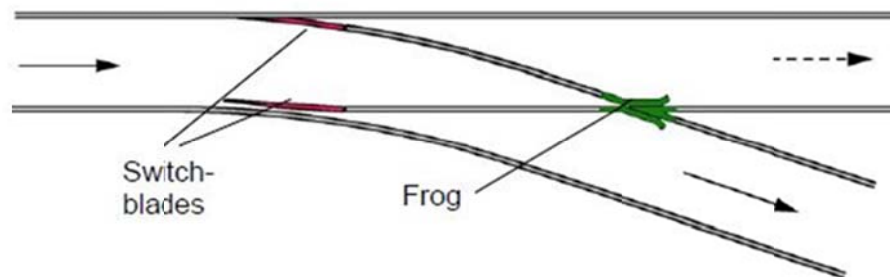

Figure 2.6 Railroad with required two switchblades
Source: Liu and Lenau, 2008

2.3.3 Station

A special station for loading and unloading capsules is required. It is assumed that UFT tunnels will be constructed on two sides of the highway with two PCP tubes, one along each side of the highway. Figure 2.7 shows UFT tunnels with stations on each side of the highway. In this figure, red lines represent the underground tunnels and black

lines show highway lanes. On the upper part of the figure, the capsules travel through the underground PCP from right to left. Likewise, capsules on the bottom of the Figure travel through the underground PCP from left to right. Openings in the station give the option to the capsules to continue along the tunnel or exit at the station. Figure 2.8 shows the exit ramp in detail. When a capsule exits a tunnel, it follows an up-ramp to the ground surface while the speed decelerates. In contrast, when a capsule enters a tunnel, it follows a down-ramp that accelerates the capsule's speed. Each capsule will then use any of these three lanes to continue, to be loaded or unloaded (Liu and Lenau, 2008).

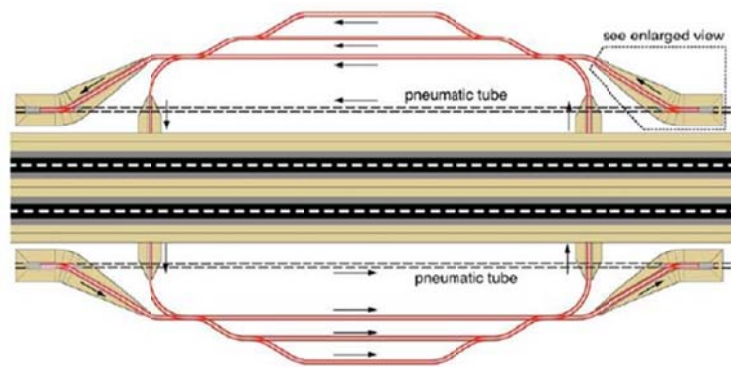

Figure 2.7 UFT tunnels with stations
Source: Liu and Lena, 2008

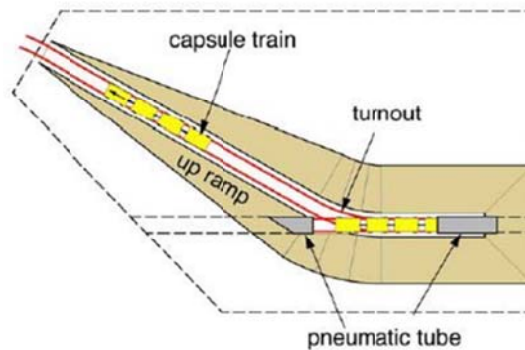

Figure 2.8 Capsule exit/entrance ramp
Source: Liu and Lenau, 2008

2.3.4 Control System

Each capsule contains a Radio Frequency Identification (RFID) tag, which has the same function of tag that is carried by cars for instant identification at toll booths. With such tags, whenever a capsule approaches a toll station. The computer that controls the station operation recognizes the cargo feature to find its destination, and decides whether to send the capsule into the outlet ramp. Once the capsule enters the station, the capsule will be directed to one of the three parallel tracks to be stopped, loaded or unloaded and immediately dispatched to its destination, or returned empty to another station for use, or sent for repair or cleaning. Loading or unloading of cargo will be done either by using forklifts, cranes, or other heavy duty equipment (Liu and Lenau, 2008).

2.4 Underground Infrastructure (Tunnels)

Tunnel infrastructure includes the structure that supports the main transport mechanism and serves as the tunnel to transport material. It is designed to have a life expectancy of 50 years. Adequate entrance/exit stations must be designed for this subterranean system. The tunnel system must be compatible with natural phenomenon such as rivers, lakes, etc., by going over it or under it; however, it is supposed to withstand natural disasters such as earthquake and floods or other destructive issues such as seepage. In addition to having a proper planning system to design and construct the tunnel, a preventive maintenance program must also be established and designed in a manner which allows personnel to effectively handle maintenance and emergencies (Roop et al., 2000).

Usually tunnels are known as covered corridors. Tunnel construction is a big challenge from the very beginning—from feasibility studies to the final commissioning. The underground construction is the major challenge other than the supporting infrastructure

since working underground faces variability (Harris, 2011). The breakdown of the tunnel delivery process is displayed in Figure 2.9.

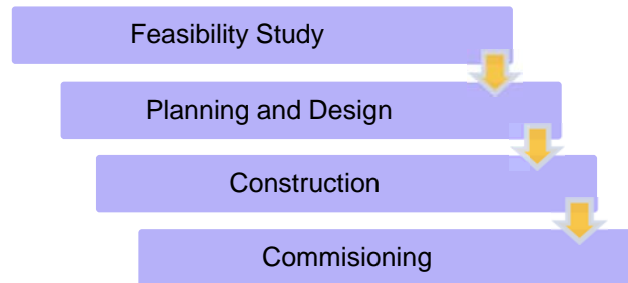

Figure 2.9 Tunnel Delivery Process
Source: Erfon and Read, 2012

2.4.1 Feasibility Study

The first step in tunneling starts with a feasibility study, which includes site investigation, preliminary design, and cost estimate. Site investigation (SI) provides more accurate information about the geological data which is critical in planning tunneling construction. Working underground deals with lots variables such as soil and rock types and potential risks, such as faults shear zones, ground water, and subsurface utilities. The more exact investigation avoids delays in the construction process and leads to a more accurate cost estimation. At the end of this phase the initial stages of design starts (Parker, 1996).

2.4.2 Planning and Design

As the tunneling project develops, the feasibility study finds the best design, which helps in the estimation of project cost. At this point, issues such as health, safety, environmental regulations, and overhead will be accounted for in both the design and budget. In this phase, designs will be more detailed by 80% to 100% (Efron, and Read, 2012). In this stage, while completing the design, an expert cost estimator develops the exact cost of the tunneling project (Efron, and Read, 2012).

2.4.3 Construction

After the completion of the planning phase, the project starts the construction phase. At this stage there are many variables to account for. Each tunnel will have a different required set of materials depending on its end-use and the ground type that will be encountered. The construction will require various amounts of material depending on the length and size of the proposed structure. The ground type will also affect the type of lining and support that the tunnel will need during and after excavation. All of these variables affect the overall complexity of the tunnel and will influence the required workforce to complete the project (Mouratidis, 2008).

2.4.4 Commissioning

Once the tunnel construction is completed, all parts need to be tested and approved. A pull out test is often done to test the strength of supports, evaluate lining thickness, and waterproof membranes if needed. These tests confirm that the tunnel is safe for service and also investigate all of the operation, electrical and mechanical equipment in the completed structure. Every part of the final outcome must be approved by the contractor, owner, and regulatory authorities before the final cost is compiled. After the completion of the tunnel there will still be costs to operate and maintain the infrastructure. These costs will vary depending on construction techniques, but that information is typically excluded from the final cost report of tunnel construction (Efron, and Read, 2012).

2.5 Construction Cost and Variables

There are numerous factors associated with constructing tunnels, which can all heavily influence the total cost. Overall, the key consideration is whether or not a cost variable will result in a statistically significant variance. This essential consideration along

with a means to measure some of the less tangible variables is crucial in calculating the overall cost (Efron and Read, 2012).

2.5.1 Geotechnical Risks

According to Hoek and Brown (1982), "One of the largest cost factors associated with tunnel construction is determining what kinds of geological conditions exist between the portals or shafts of a tunnel. "Modern geotechnical engineering software analyzes rock type and groundwater infiltration. However, even though this software provides acceptable information regarding the soil condition, it is not fully reliable. Construction management usually adds a percent of contingency to soil reports based on previous projects to use in the proposed project (Pells, 2002)

The inaccuracy of geotechnical information makes the type of subsurface one of the largest factors in the variance of tunneling costs. The ideal soil type for tunnels is usually soft homogenous rock. The complexity enhances when tunneling leads to boring through gravels or sand, because of the high permeability and low structural stiffness. Tunneling can be even more complicated while boring through heterogeneous subsurface, such as a combinations of hard rock, sands, and water pockets. In this case, identifying the soil weaknesses and determining a solution affects the project cost (Hoek and Brown, 1982).

2.5.2 Location

Location is one of the critical factors, which affects cost. Construction, based on location can be categorized as urban and non-urban. Construction in an urban area is often more expensive due to different factors. The cost of real estate and easements can be considerably higher in urban areas, in addition to the cost of multiple long term shaft site locations on the surface. Additionally, there are limitations in operational hours and

weight of the material and equipment which must be hauled into urban areas (Efron and Read, 2012).

Complications also exist for non-urban areas such as the cost of long distance driving or the need to build a plant nearby to provide construction materials. Additionally, if the project is significantly far from the labor source, it is often necessary to set up temporary housing for the workers (Efron and Read, 2012).

2.5.3 Design

Every country has their own rules and regulations to design infrastructure projects. Some countries may have more strict rules to ensure the safety requirements and public needs are met. In this case the project cost will be affected by these rules, which has to be applied to the designs (Lieske, 2008).

Generally, when more restrictions are enforced, it takes a lot more time to develop the design. This process can be seen in countries such as United States, Australia, and European countries. However, some research has been conducted to determine the actual amount of time required to design a tunneling project, which was difficult because of the variable parameters such as contract type, project type and the system of government (Lenferin, 2009).

2.5.4 Safety Regulations

This parameter, just like design parameter has a huge dependency on government rules and regulations for safety. Generally, safety consideration costs can be divided in two categories: construction costs and workers safety costs. In construction costs, construction companies are obligated to provide safety equipment and high levels of insurance. These costs may vary depending on location, because different governments may have differing levels of worker safety (Hinze, 2008).

An example of a construction safety cost is proper ventilation, which is necessary to provide for the health of workers during construction. These costs can be very high and often result in construction management companies making the bare minimum investment in safety required by the regulations imposed by the government. Although these regulations have resulted in a great improvement in safety statistics in many countries, other countries still lag behind in safety requirements. Additionally, there are costs to provide for the safety of the end-user after construction (Hinze, 2008).

2.5.5 Environmental Regulations

Environmental regulations are other factors which have big impacts in determining the cost. Some countries develop documents as an environmental impact assessment (EIA) which determines the impact of every activity on the environment. In this case, extra costs are applied for cleanup, removal and disposal of waste products, and there may be certain regulations for industrial waste disposal which affects construction cost (Gurtoo and Antony, 2007).

2.5.6 Contingencies

Although there is some variance in the way in which companies formulate bids for projects in different regions, most construction management firms have a good idea of the local issues associated with bidding on a project. Typically, due to unexpected ground conditions that may cause delays, contractors assign a higher contingency (Touran, 2003).

2.5.7 Material/Labor

The cost estimation for material and labor is a complicated process which is done by contractual companies. It is difficult to compare data on infrastructure project estimates across different contracting firms due to a lack of standard parameters in the

industry. It also should be mentioned that the price index between countries will be different and should be considered when using different sources of data (Crighton, 1992).

The cost and productivity of the labor force are considerable factors when estimating the construction cost. Government regulations can also have a significant impact on labor costs. Finally, Riegger (2008) noted that “Local and national governments can pass legislation requiring not only minimum wages, but also benefits like health insurance, which over time can significantly increase cost of labor.”

2.6 Tunnel Construction Methods

There are various methods available for tunnel construction depending on project conditions. In the following sections, the two methods of Tunnel Boring Machine (TBM), and Cut-and-Cover are discussed.

2.6.1 Tunnel Boring Machine (TBM)

TBMs are basically large-diameter horizontal drills used for tunnel excavations. Based on soil categories, self-support and non-self-support rock TBMs and slurry shield TBM are used, respectively (Federal Transit Administration and MTA New York City Transit, 2015).



Figure 2.10 Tunnel Boring Machine
Source: http://web.mta.info/capital/sas_docs/feis.htm

Both types of TBMs encompass a cutter head followed by several hundred feet of machinery. This machinery runs the cutter head, moves the spoils, and rotates the TBM cutter head. The cutter head surface is covered with numerous steel bits. As the cutter head rotates, the soil is cut to assist in the construction of the tunnel (Federal Transit Administration and MTA New York City Transit, 2015).

After boring, the tunnel's pre-cast or cast-in-place liners are used to complete the tunnel. After placing the liner, any voids are sealed with cement grout under pressure (Federal Transit Administration and MTA New York City Transit, 2015).

With a rock TBM, the exposed rock tunnel wall is secured directly behind the drilling head with rock bolts, precast concrete, or other techniques. In slurry TBMs, thrust arms are used to support the excavation area and the tunnel at the same time. Tunnels created with slurry shield TBMs are secured by locating an enclosed pressurized compartment at the tunnel face, and then exerting pressure provided by pumping a bentonites slurry into the area. Often, the top of the excavation chamber is also pressurized with air (an "air bubble slurry machine"). The slurry TBM constantly removes the soil and slurry mixture from the tunnel and replaces the mixture with new slurry at the tunnel face. The removed slurry is then separated from the excavated soil slurry plant near the tunnel alignment, and returned to the tunnel for reuse. An "Earth Pressure Balance Machine" (EPBM) TBM is similar to a slurry shield TBM, except that the pressure at the tunnel face is provided by a plug of excavated soil (Federal Transit Administration and MTA New York City Transit, 2015).

Behind the cutter face, TBMs are mobilized with computers which control TBMs operation. This equipment includes pumps, transformers, and grouting equipment, as well as mechanisms for removing the excavated rock or soil and moving it back behind

the machine either by rail or conveyor (Federal Transit Administration and MTA New York City Transit, 2015).

With all these components, TBMs are very large pieces of equipment that are brought to the start of the tunnel operation and lowered into the ground in pieces, where they are assembled at the base of a shaft in a large underground chamber. TBMs excavate circular openings typically inches bigger (in diameter) than the TBMs themselves. The openings are subsequently lined or supported immediately behind the TBM, which effectively reduces the opening diameter to less than that of the TBM. Thus, the machines cannot be pulled backwards unless pieces of the machinery are disassembled and reassembled elsewhere. Generally, it is faster (and therefore more economical) to remove the machines entirely rather than attempt to reverse them or pull them back (Federal Transit Administration and MTA New York City Transit, 2015).

2.6.2 Cut-and-cover

Cut-and-cover construction entails cutting the ground surface open and then backfilling over the surface once construction is complete. During construction, a temporary surface covering (or deck) is generally placed over portions of the cut to minimize disruption at the surface and to facilitate traffic flow. Once construction is complete, the excavation above the finished structures is backfilled, and the streets are repaved and fully reopened for traffic. Because of the disruption that cut-and-cover construction can cause, it can only be used in areas where there is inadequate cover to allow safe and stable underground mining (Mouratidis, 2008).

Cut-and-cover method always requires some excavation of the tunnel and station areas from the street surface. Typically, using various methods of bracing to support the excavation sides and to limit movement of the surrounding ground, the street is excavated to allow the opening to be covered by a deck system (Mouratidis, 2008).

Once the deck is installed, portions of the streets and sidewalks can be reopened to allow limited vehicular traffic and pedestrian flow while construction continues underneath the decks. However, as for any construction below ground surface, covered cut-and-cover construction still requires a continuous vehicle lane and partial sidewalk closures to permit access and egress by workers, equipment, and materials, and to accommodate spoils removal (Mouratidis, 2008).

2.7 Chapter Summary

This chapter initially covered different UFT methods and previous research on feasibility of UFT. Then the components of UFT were discussed. Four tunnel construction phases were introduced. Finally, the main factors that impact construction of tunnels and its cost were presented.

Chapter 3

Case Study

3.1 Background

Traffic congestion is one of the most important challenges that New York City, as one of the largest cities in the world, is faced with. The congestion may have consequences such as loss of productivity due to the time spent in traffic, lower highway safety due to vehicular accidents, waste of energy in traffic congestion and air pollution. To investigate the solutions for this problem, Liu (2004) conducted research sponsored by the New York State Energy Research and Development Authority (NYSERDA) to establish the feasibility of PCP UFT in New York City.

This research illustrated that multiple approaches and technologies must be used to solve New York City's transportation problems. The approaches include increased use of bicycles, increased use of mass transit, increased use of rails for passenger and freight transport, limiting truck delivery to off-peak traffic hours, reduced time for street repair that will block traffic, building additional tunnels across the Hudson River to alleviate traffic to and from New Jersey, and so forth. However, Underground Freight Transportation can be used as a complementary method to alleviate traffic congestion issues in New York City.

3.2 Methodology

Liu studied the feasibility using PCP in New York through assessment of modern technologies in UFT as well as identifying potential PCP applications.

3.2.1 Technology Description

PCP (Pneumatic Capsule Pipeline) utilizes wheeled capsules (vehicles) to transport freight through large-diameter underground pipes of the order of 36 in. Air is blown through the pipe to move the capsule. Besides PCP, an electromagnetic pump

(linear induction motor) which is an improved capsule propulsion system has been studied and deemed useful as a solution to PCP problems (Source: Liu, 2004). Figure 3.1 shows a round PCP and rectangular PCP

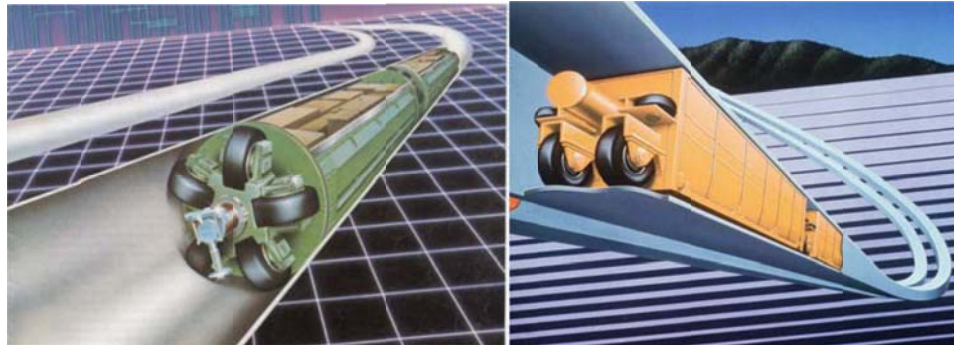

(a) (b)
Figure 3.1 Pneumatic Capsule Pipeline (a) shows a Round PCP and (b) is a Rectangular PCP (Sources: a): Kosugi, 2000; b): Liu, 2004)

3.2.2 Potential Applications to New York City

Various applications were considered for PCP in New York. The major applications are discussed below:

3.2.2.1 Tunnel Construction

In the construction of large tunnels, the excavated soil is moved by trucks. The trucks need to be hoisted into the access shaft and hoisted out when loaded. This process is costly and may also result in delay in construction of the tunnels. PCP can be used as an alternative to transport excavated material by the tunnel boring machine (TBM) from the tunnel to the dump site (Liu, 2004). Figures 3.2 and 3.3 show a PCP system used in a tunnel construction project in Japan.



Figure 3.2 Tunnel entrance
(Source: Liu, 2004)



Figure 3.3 PCP extending outside the tunnel to the dump site
(Source: Liu, 2004)

3.2.2.2 Transporting Pelleted and Other Goods (Pallet-Tube System)

The features of the Pallet-Tube System is the same as regular PCP; however, since most of the goods delivered by trucks in New York City come on pallets or in boxes, a PCP system, able to handle pallet sized goods was considered. Figure 3.4 shows the cross section of pallet- tube PCP for New York City (Liu, 2004).

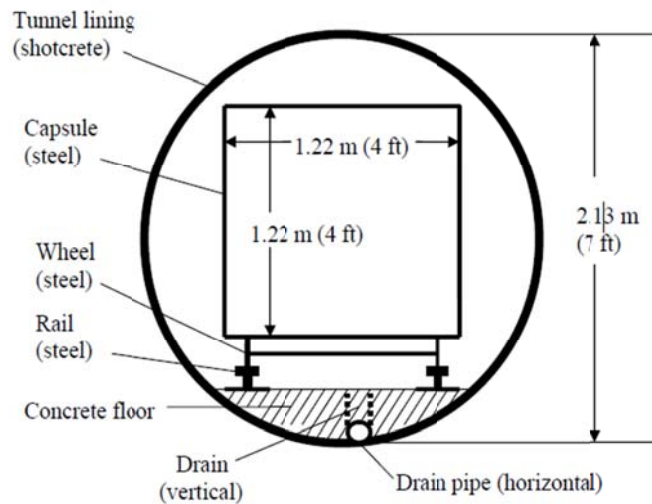

Figure 3.4 Cross-section of the pallet-tube PCP for New York City
Source: Liu, 2004

3.2.2.3 Solid Waste Transport

New York City generates a large volume of residential and industrial solid waste every day. The generated solid waste needs to be collected and transported to landfills around the New York metropolitan area. PCP can be employed to reduce the number of trucks transporting solid waste on New York streets and highways (Source: Liu, 2004).

3.2.3 Routes

Hunts Point is the place in New York City where the City's foods are processed, serving millions of people in the New York Metropolitan area. It has the nation's largest produce processing center, and the nation's largest meat processing center (Source: Liu, 2004). Each day, over 3,000 trucks of various sizes enter Hunts Point from its north and proceed to its south, either to pick up the processed foods from or deliver the unprocessed foods to the food processing centers, which are located next to each other in the southeast corner of Hunts Point along Food Center Drive (Source: Liu, 2004). The

high-density truck traffic in Hunts Point has caused not only accidents but also severe air pollution (Liu, 2004).

Figure 3.5 shows two PCP alternative routes, which were studied in this case study. Route AB and CD. The study considered various aspects such as geology, urban development, intersections with existing underground utilities and access to freeways. The study found that the east route, CD, was preferable (Liu, 2004).

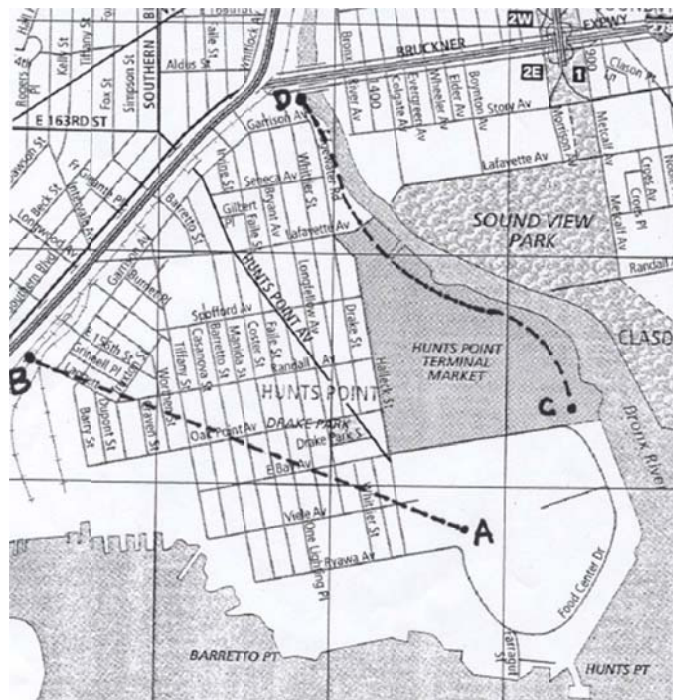

Figure 3.5 Proposed alternative PCP routes (AB and CD) investigated for ferrying trucks across Hunts Point (Source: Liu, 2004)

3.3 Cost Analysis

It is expected that the most costly item of this project is the tunneling cost. Therefore, it is important to evaluate the tunneling cost as accurate as possible so that the total cost can be determined accurately. Unfortunately, many construction factors cannot be determined in feasibility study. Thus, tunneling costs vary greatly with many different factors, making it difficult if not impossible to determine accurately without

detailed engineering design and site exploration. Since such detailed engineering site investigation is not possible for this feasibility research, only a rough estimate of the tunneling cost is possible. An alternative way to estimate such costs is to find out the unit-length cost of similar tunnels built in New York City using TBMs, then to adjust the unit-length cost for each case according to the tunnel diameter, which is the single most important factor affecting the unit cost of tunnels built under similar conditions in New York City. This assumption enables us to use a simple formula of the following form for estimating purpose as an alternative:

$$\text{Equation: } C = KD^N$$

In this equation, C is the cost in dollars per linear foot of tunnel; K is a constant that must be determined from reliable existing cost data; D is the tunnel diameter in feet; and N is a constant greater than one but less than 2. If the tunneling cost is assumed to be proportional to the volume of the earth removed during tunneling, then N will be equal to 2. In reality, due to cost-effectiveness of using large tunnel boring machines, the value of N is expected to be somewhat smaller than 2 – in the neighborhood of 1.7. Therefore, unless otherwise proven by reliable cost data, the value of N is assumed to be 1.7 (Yu et al, 2008).

3.4 Case Study Conclusions

This research study concluded that it is both technically and economically feasible to use the technology of pneumatic capsule pipeline (PCP) to transport freight in New York City for a variety of cargoes including construction materials, municipal solid waste, mail and parcels, goods normally transported on pallets or in boxes, crates and bags, and entire containers.

3.5 Chapter Summary

This chapter presented an overview of the project conducted on feasibility of underground pneumatic freight transportation in New York City. PCP modern technologies were discussed, potential applications of PCP in New York were presented and the proposed routes for PCP construction in New York were discussed. Finally the conclusions of this research were presented.

Chapter 4

Survey on Feasibility of Underground Freight Transportation (UFT) in Texas

4.1 Introduction

To supplement the literature research, a survey was conducted with several tunneling, design, and construction companies as well as transportation planning and engineering firms in Texas to obtain their comments and expertise in underground freight transportation. The survey gathered valuable technical information on key elements of underground freight transportation.

4.2 Methodology

The survey consisted of 14 questions which included multiple choice, essay and rank questions. Under each question a comment box was designed so the respondents could provide their feedback. The survey was sent to more than 150 individuals in various freight transportation fields of expertise such as engineering and design, planning, contracting, operating and regulating in Texas. A total number of 57 responses were received out of which 30 responses were provided by individuals with experience in freight transportation in Texas.

The survey included three major types of questions—multiple choice, essay, and ranking. Multiple choice questions were analyzed and presented in a pie chart format. In ranking questions, to enable a comparison among provided options, weights were assigned to the options based on their degree of desirability. For instance, in the question which asked for ranking the most desirable UFT size among Small, Medium and Large, the option which ranked the 1st received a weight of 3, and the option that was ranked 2nd received a weight of 2. The option that was ranked as the least favorable received a weight of 1. Then the weighted average was calculated for each alternative. The option

that received the highest weighted average score was determined as the most desirable answer. Ranking questions results were presented in a bar chart format.

4.3 Objectives

The objective of the survey was to obtain as much information as possible on feasibility of UFT in Texas through a survey that was sent to professionals involved with freight transportation in Texas.

The survey questionnaire was prepared under the supervision of Dr. Mohammad Najafi and was sent to more than 150 tunneling design and construction and transportation design and construction firms in Texas. A total number of 57 responses were received out of which, 30 had previous experience in freight transportation in Texas. To ensure reliability of the results, only collected responses from respondents with previous involvement in freight transportation in Texas were considered. The Survey Monkey software was used to send questionnaires.

4.4 Questionnaire and Results

Question 1: Have you been involved in any freight transportation projects in any capacity in Texas?

Figure 4.1 shows whether or not the 30 respondents were previously involved with Freight Transportation in Texas. The purpose of this question was to limit the respondents to those who had experience in Freight Transportation. This will increase the reliability of the answers. Table 4.1 shows the actual number of respondents to each question.

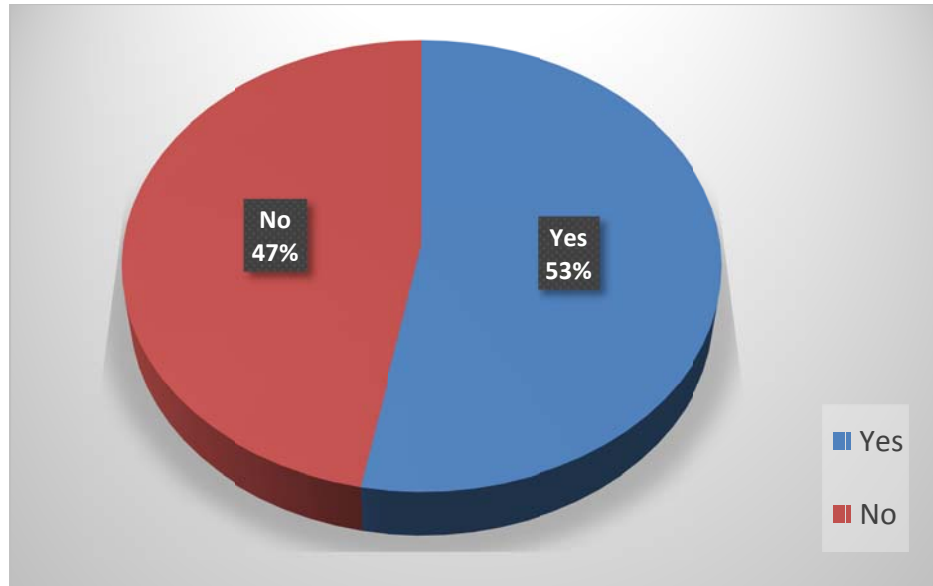

Figure 4.1 Respondents Involvement with Freight Transportation

Table 4.1 Respondents Involvement with Freight Transportation

With UFT Experience	30	53%
Without UFT Experience	27	47%
Total Number of Responses	57	100%

Question 2: Please specify your type of involvement with freight transportation in Texas.

Figure 4.2 presents the distribution of survey participants. The majority of the survey respondents were involved in Freight Transportation Engineering and planning. Regulating was ranked the third popular group. Table 4.2 shows the actual number of respondents to each question.

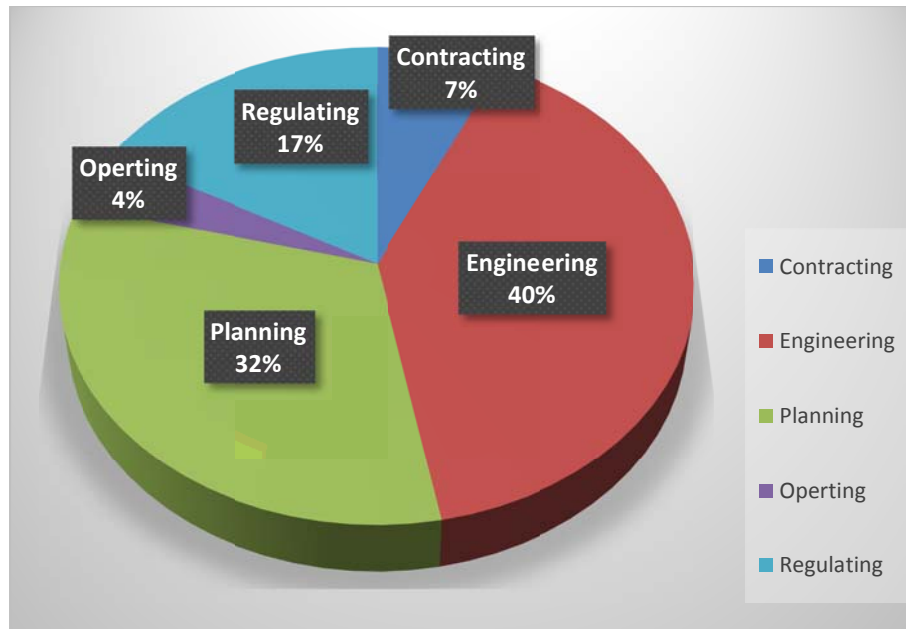

Figure 4.2 Distribution of Respondents Involvement with Freight Transportation

Table 4.2 Distribution of Respondents Involvement with Freight Transportation

Engineering	12	40%
Planning	10	32%
Regulating	5	17%
Contracting	2	7%
Operating	1	4%
Total Number of Responses	30	100%

Question 3: Do you think that UFT will be cost effective and competitive with other modes of freight transportation in Texas, such as trucks and railroad?

Figure 4.3 shows that the majority of the respondents believe that underground freight transportation will not be competitive and cost effective compared with other modes of transportation such as trucks and railroad. However, some of the responses state that the growing demand for freight transportation increases the need for new

modes of freight transportation such as UFT. Followings are some of the comments from the respondents:

- UFT is a complementary system to the existing transportation system. It has lots of advantages which makes it essential to the next generation of the freight transportation system. Although the capital cost is high, its benefits in long term will make it logical.
- Cost of UFT is likely prohibitive. It is unlikely that the cost / benefit ratio will be favorable for long range deployment.
- UFT could be cost effective and competitive in some markets depending on the willingness of manufacturing companies to shift from a proven mode. Also, rail and trucking companies were approached in the study as they possibly could be the builders and/or operators of the UFT.
- I guess as the railroads of Texas are fully developed and serve the major areas of state, UFT may be only cost effective in transportation of certain materials within highly populated cities such as Houston or Dallas. In other areas it may not be very necessary yet.
- The infrastructure costs for UFT would be prohibitive; not just the transportation lanes but terminals too.

Table 4.3 shows the actual number of respondents to each question.

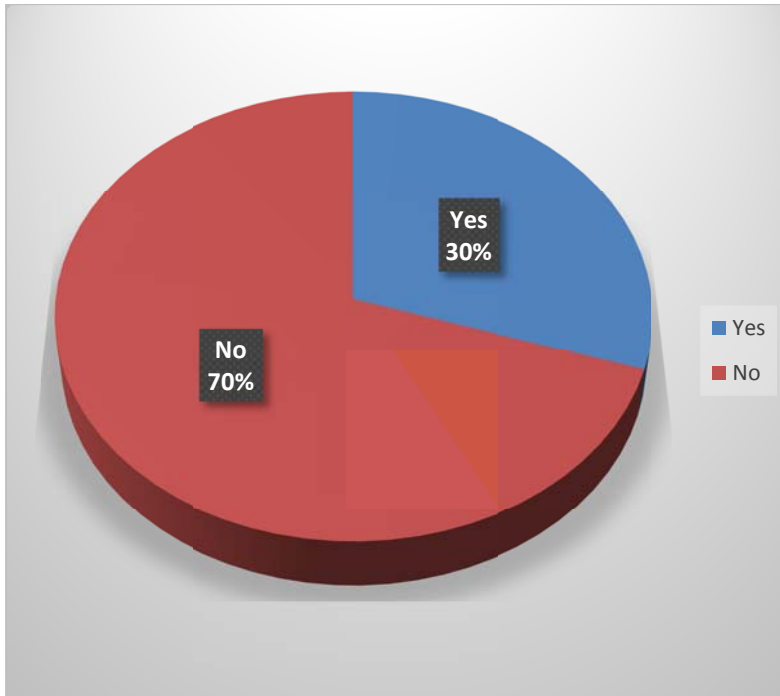

Figure 4.3 Cost Effectiveness of UFT

Table 4.3 Cost Effectiveness of UFT

UFT is Cost Effective	9	30%
UFT is Cost Effective	21	70%
Total Number of Responses	30	100%

Question 4: Do you foresee UFT to be a part of inter-modal freight transportation in Texas?

Figure 4.4 shows that the majority of respondents believed that UFT would not be a part of inter-modal freight transportation system in less than 15 years. It shows that there is a need for study on the feasibility of UFT. Table 4.4 shows the actual number of respondents to each question.

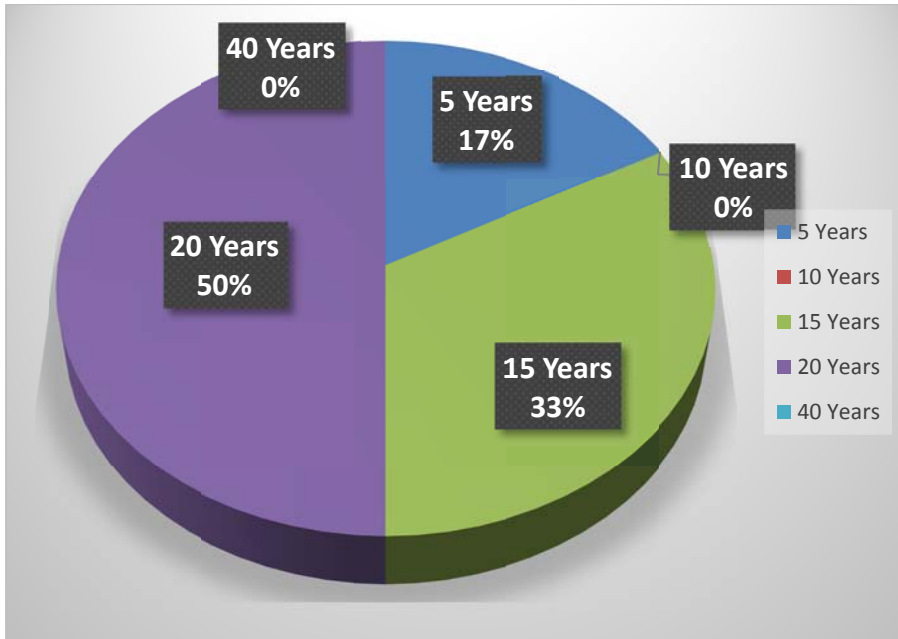

Figure 4.4 UFT Expected Construction Date

Table 4.4 UFT Expected Construction Date

5 Years	5	17%
10 Years	0	0%
15 Years	10	33%
20 Years	15	50%
40 Years	0	0%
Total Number of Responses	30	100%

Question 5: What method of construction is most applicable for an underground freight transportation project in Texas? Please rank from 1 to 4, with 1 being the most and 4 being the least.

The respondents were asked to choose the most applicable construction methods for construction of UFT in Texas. Figure 4.5 shows the responses received for this question. To make a comparison among proposed UFT construction methods, the

average weighted score for each method is calculated. As shown in Figure 4.5, open-cut tunneling¹ has received the highest weighted average score. Tunneling², Box Jacking³ and Pipe Jacking⁴ are in the second to fourth place. Table 4.5 shows the actual number of respondents to each question.

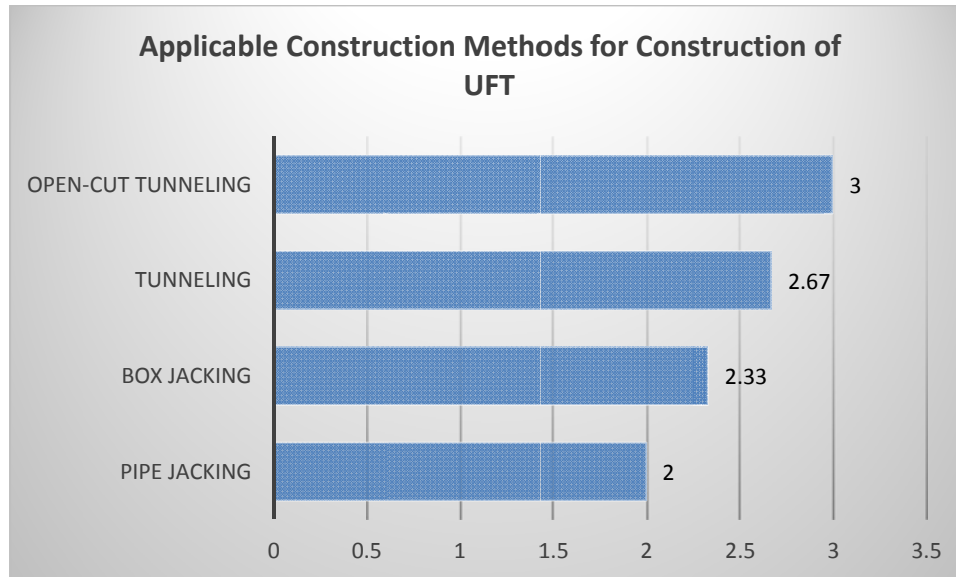

Figure 4.5 Applicable Construction Methods of UFT

¹Open-cut Tunneling method has been the conventional technology for tunnel construction which includes digging a trench and constructing a tunnel (Najafi, 2013).

²Tunneling is a Trenchless method used to install new tunnels underground. The tunneling procedure is the same as Pipe Jacking method except temporary supports are needed in this method. Tunneling, is a two-step operation, where soil is excavated, a liner is installed, and then the pipe is transported inside the tunnel. The liner can be special steel or concrete liner plates (Najafi, 2013).

³Box Jacking is a Trenchless Construction method used to install rectangular box culverts under existing facilities such as highways and railroads. In this method, box culverts are pushed through the ground using the thrust power of a hydraulic jack. Due to excavation methods and space requirements, the box culverts need to be large enough to provide adequate space for excavation (Najafi, 2013).

⁴Pipe Jacking is a Trenchless Construction method for installation of a new prefabricated pipe underground from a drive shaft to a reception shaft. It includes a cyclic method that uses the thrust power of hydraulic jacks to propel each segment of the pipe through the ground (Najafi, 2013).

Table 4.5 Applicable Construction Methods of UFT

UFT Challenges	1	2	3	4	5
Constructability Issues	6	8	6	5	5
Operational Problems	7	7	2	7	7
Lack of Government Support	5	7	6	7	5
High Cost	5	5	6	8	6
Availability of Funds	3	4	10	10	3

Total No. of Respondents: 30

Question 6: What are the most challenging problems for traditional modes of freight transportation (such as, truck, railroad, air, etc.?) In Texas?

Followings are some of the responses:

- The congestion and social costs that have been made in last decade and will be more in the future. Also a lack of security these days has made the UFT a must for our transportation system
- Infrastructure costs
- Air pollution, high energy consumption
- Safety, traffic congestion, security of the cargoes

Question 7: For the following, please rank from 1 to 5, with 1 being the least and 5 being the most challenges of UFT:

Figure 4.6 below shows the weighted average score for each factor. Based on the survey results, the constructability issues are the most challenging factor which affects UFT. Operational problems and lack of government support were in the second place. High cost and availability of funds were ranked the 4th and 5th challenging factors. Table 4.6 shows the actual number of respondents to each question.

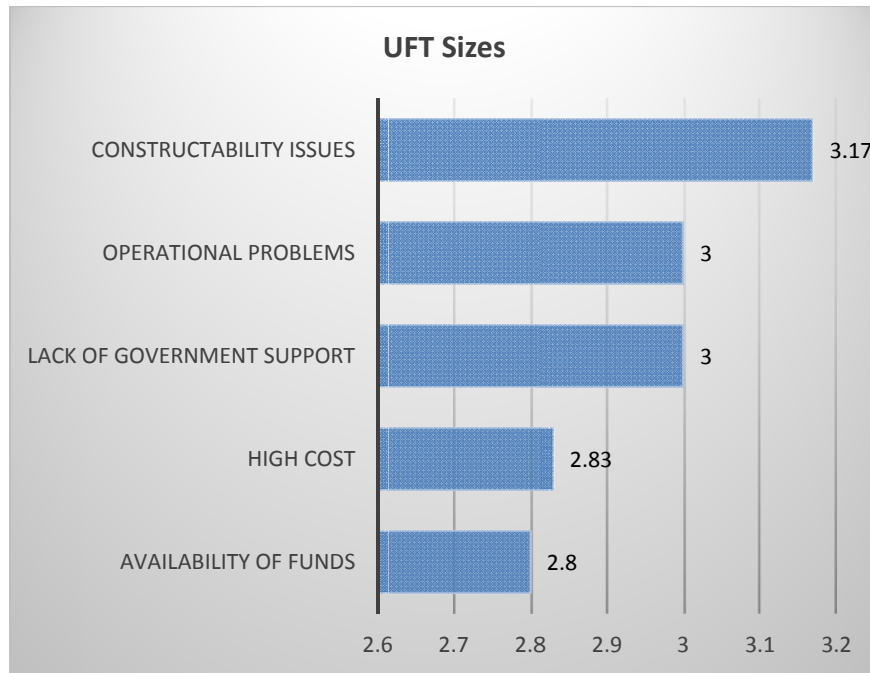

Figure 4.6 UFT Challenges

Table 4.6 UFT Challenges

UFT Challenges	1	2	3	4	5
Contractibility Issues	6	8	6	5	5
Operational Problems	7	7	2	7	7
Lack of Government Support	5	7	6	7	5
High Cost	5	5	6	8	6
Availability of Funds-	3	4	10	10	3

Total Respondents: 30

Question 8: Among the following, please rank from 1 to 10, with 1 being the least and 10 being the most obstacles for construction of UFT in Texas.

From Figure 4.7 it is concluded that open-cut construction and open-cut construction are the most important obstacles involved with UFT followed by

underground water control, soil conditions, spoil removal and excavation support. Table 4.7 shows the actual number of respondents to each question.

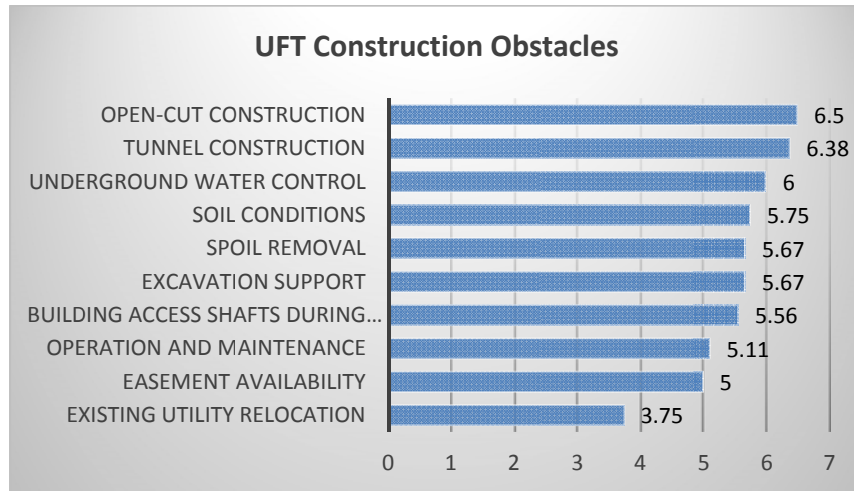

Figure 4.7 UFT Construction Obstacles

Table 4.7 UFT Construction Obstacles

UFT Construction Obstacles	1	2	3	4	5	6	7	8	9	10
Open-cut Construction	4	0	4	4	2	3	3	1	1	0
Tunnel Construction	4	4	2	1	2	2	2	2	2	1
Underground Water Control	4	3	2	1	2	2	2	2	2	2
Soil Conditions	3	3	3	0	3	3	0	2	2	3
Spoil Removal	2	2	2	2	3	2	2	2	2	2
Excavation Support	2	2	3	3	2	2	2	2	2	2
Building Access Shaft	3	2	2	2	2	3	1	2	2	3
Operation and Maintenance	1	1	1	3	4	3	3	3	2	1
Easement Availability	1	1	2	2	2	4	4	4	4	0
Existing Utility Relocation	0	0	0	1	3	4	4	4	4	2

Total Respondents: 22

Question 9: What size of UFT is most effective? Please rank from 1 to 3, with 1 being the most and 3 being the least.

Figure 4.8 shows that large UFT with the dimensions of 10 ft x 10 ft x 50 ft, which can be used to transport large containers, is the most appropriate size for UFT. Medium UFT with the dimensions of 5 ft x 5 ft x 12 ft, which is capable of handling mini containers is ranked the second most appropriate size for UFT. Table 4.8 shows the actual number of respondents to each question.

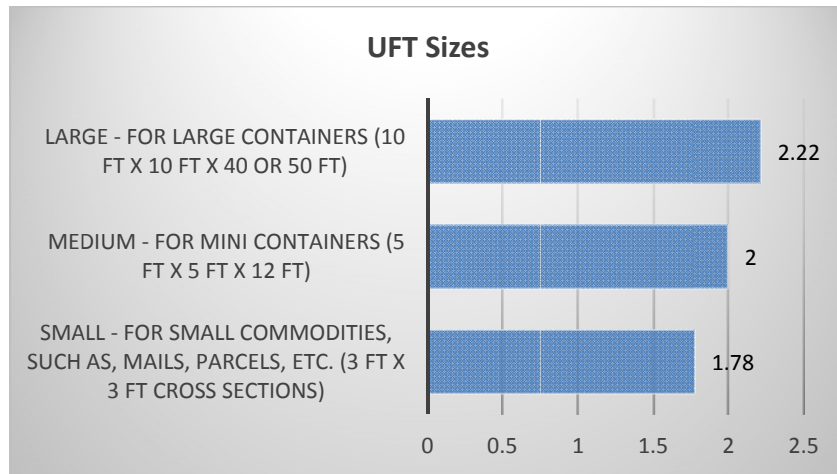

Figure 4.8 Applicable UFT Sizes

Table 4.8 Applicable UFT Sizes

UFT Size	1	2	3
Large	13	10	7
Medium	9	12	9
Small	6	11	13

Total Respondents: 30

Question 10: What size of UFT might be a good candidate for the routes listed below in Texas? Please rank from 1 to 3, with 1 being the most and 3 being the least.

Figure 4.9 illustrates the distribution of responses for proposed routes and UFT sizes. It is concluded from the graph that a large UFT was the most appropriate size for Port of Houston to a distribution center in Dallas and the border with Mexico at Laredo to a distribution center in Houston. As shown in the graph, Medium UFT is a good candidate for the Port of Houston to a distribution center outside of Houston and DFW airport to a distribution center within 10 miles. As shown in the graph, Medium UFT is a good candidate for the Port of Houston to a distribution center outside of Houston and DFW airport to a distribution center within 10 miles. Table 4.9 shows the actual number of respondents to each question.

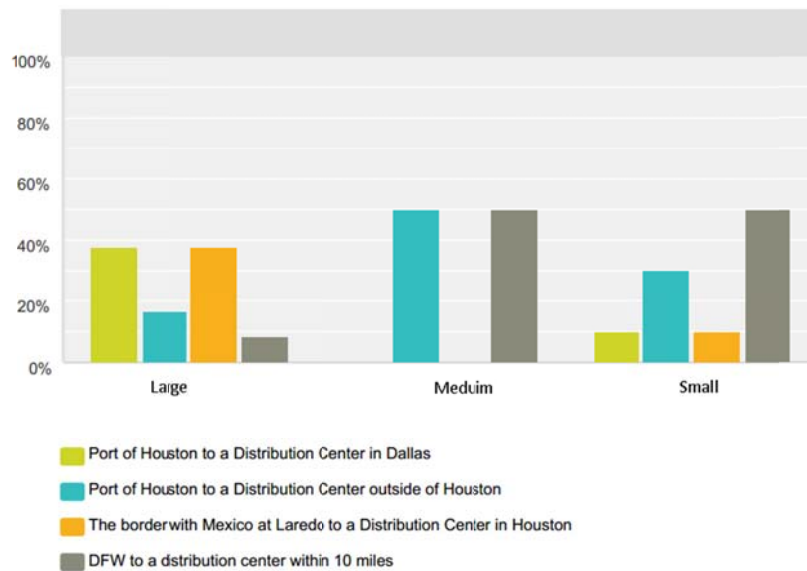

Figure 4.9 Applicable UFT Sizes for Proposed Routes

Table 4.9 Applicable UFT Sizes for Proposed Routes

Proposed Routs	Large	Medium	Small
Port of Houston to a Distribution Center in Dallas	8	0	2
Port of Houston to a Distribution Center Outside Houston	3	10	6
The border with Mexico at Laredo to a Distribution Center in Houston	8	0	2
DFW Airport to a Distribution Center within 10 miles	1	10	10

Total Respondents: 20

Question 11: Please give us your suggestions for additional routes that might be a candidate for UFT in Texas.

The followings are some of the suggested route:

- Laredo or Eagle Pass to the DFW area.
- Small size UFT from Austin (the capital of Texas) to Houston or Dallas.
- Within metropolitan areas from existing collection centers to distribution centers. One example would be postal centers in the DFW metropolitan area.
- El Paso to DFW.

Question 12: Among the following, please rank the benefits of UFT in Texas?

Please rank from 1 to 9, with 1 being the most and 9 being the least.

Figure 4.10 illustrates the most important benefits of UFT. As shown in the Figure below, reducing traffic congestion, enhancing highway safety and increasing reliability were the most important benefits of UFT. Table 4.10 shows the actual number of respondents to each question.

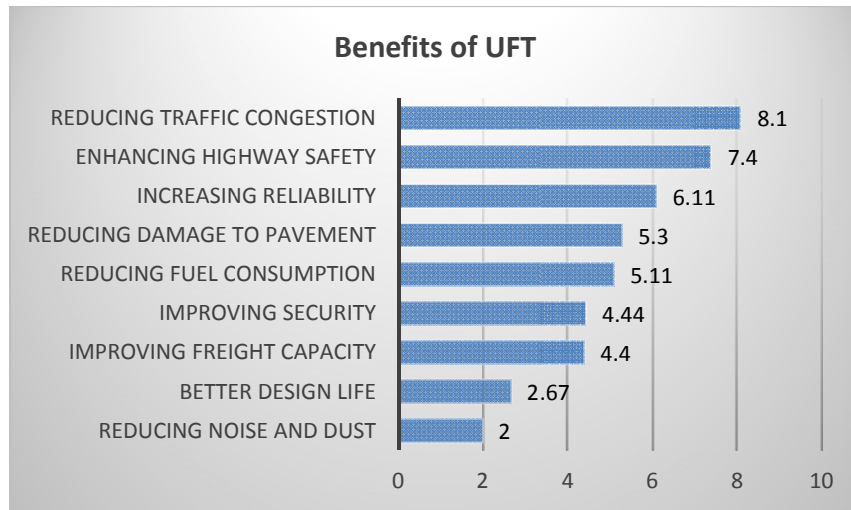

Figure 4.10 Benefits of UFT

Table 4.10 Benefits of UFT

UFT Benefits	1	2	3	4	5	6	7	8	9
Reducing Traffic Congestion	13	9	7	0	1	0	0	0	0
Enhancing Highway Safety	9	8	7	1	2	2	1	0	0
Increasing Reliability	7	4	4	3	3	4	2	2	1
Reducing Damage to Pavement	4	4	3	3	3	4	4	4	1
Reducing Fuel Consumption	3	3	4	4	4	4	3	2	3
Improving Security	2	2	2	2	6	5	5	4	2
Improving Freight Capacity	2	2	2	2	5	5	5	3	4
Better Design Life	0	1	1	1	0	3	7	8	9
Reducing Noise and Dust	0	0	1	0	0	1	5	6	12

Total Respondents: 30

Question 13: What type of financing might be best suitable to construct and operate UFT in Texas? Please rank from 1 to 4, with 1 being the most and 4 being the least.

After analyzing the responses and calculating the weighted average scores for each financing method, Public Private Partnership¹ (PPP) was selected as the most appropriate financing method followed by Public-Public² financing method. Figure 4.11 shows PPP was the most appropriate financing method. Table 4.11 shows the actual number of respondents to each question.

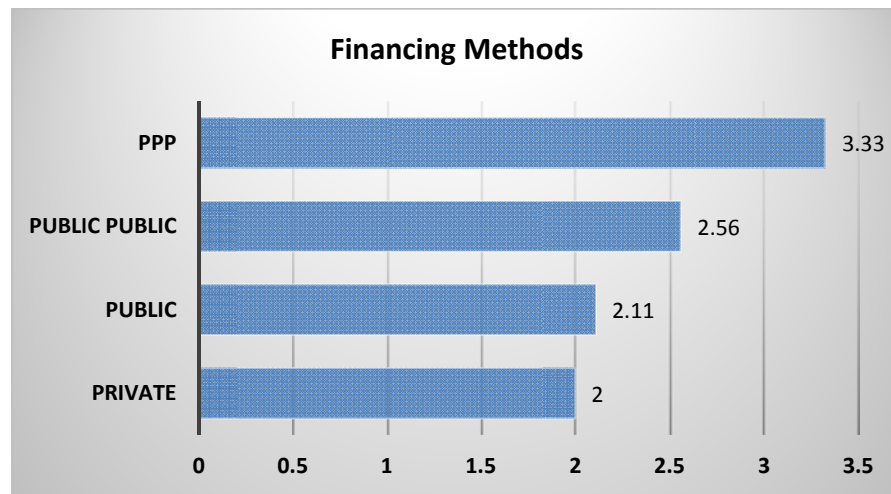

Figure 4.11 Applicable Financing Methods

Table 4.11 Applicable Financing Methods

Financing Methods	1	2	3	4
PPP	20	4	2	4
Public- Public	7	9	8	6
Public	3	7	10	10
Private	3	5	11	11

Total Respondents: 30

¹A public-private partnership is a contractual agreement formed between public and private sector partners, which allows more private sector participation than is traditional. The agreements usually involve a government agency contracting with a private company to renovate, construct, operate, maintain, and/or manage a facility or system (Khankarli, 2009).

² A public-public partnership that combines various forms of cooperation and integration between public sector entities to finance investment in public infrastructure and/or to carry out joint tasks (Khankarli, 2009).

Question 14: What type of delivery method might be best suitable to construct and operate UFT in Texas? Please rank from 1 to 4, with 1 being the most and 4 being the least:

Below, Figure 4.12 shows the applicable delivery methods for construction of UFT. As it is presented in the figure below, nearly 70 percent of the respondents chose design-build-operate-maintenance (DBOM) as the most appropriate delivery method followed by Design Build (DB) by 14 percent. Table 4.12 shows the actual number of respondents to each question.

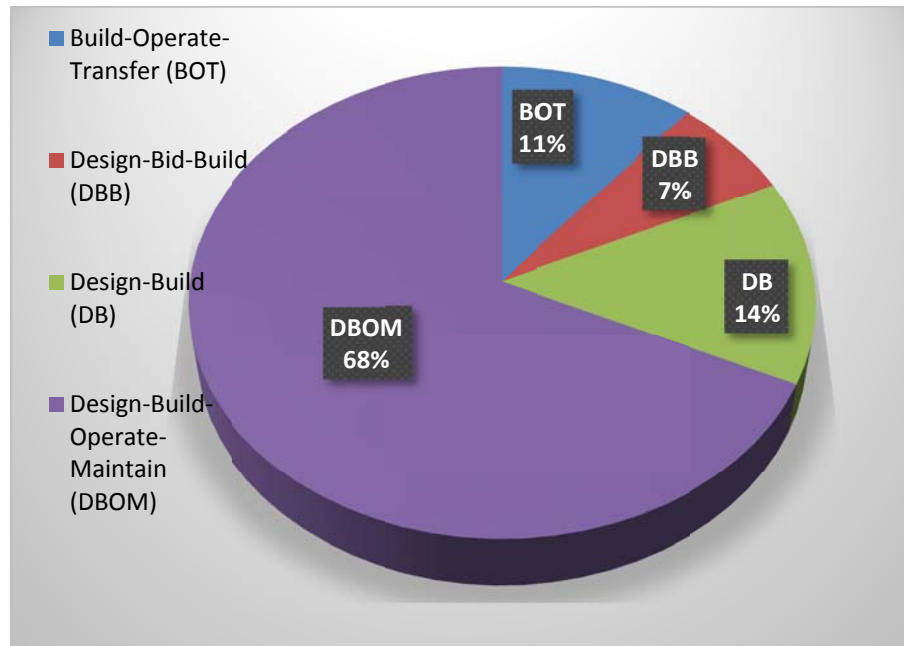

Figure 4.12 Applicable Delivery Methods

Table 4.12 Applicable Delivery Methods

DBOM	21	68%
DB	4	14%
BOT	3	11%
DBB	2	7%
Total Number of Responses	30	100%

4.5 Analysis of Results

According to the respondents cost effectiveness is one of the most important factors that limits the UFT competitiveness with other freight transportation methods such as trucks or rail road. In order to have a more productive UFT, large cargoes for long distances and small cargos for short distances were suggested.

The most challenging element in constructing UFT is tunnel construction, and the most beneficial part of UFT was reducing traffic congestion and increasing the number of highways safety.

4.6 Chapter Summery

This chapter showed that UFT can be used as an effective method of transportation to address the increasing demand for freight transportation in the next 15 to 20 years. Reducing traffic congestion and enhancing highway safety were ranked as the most important benefits of UFT. However, 70 percent of the respondents believed that high construction cost could affect the feasibility of UFT in the short term. Survey results also stated that large UFTs from the port of Houston to a distribution center in Dallas and large UFT from the port of Mexico at Laredo to a distribution center in Houston were ranked as the most appropriate options.

Chapter 5

Discussion of Results

5.1 Introduction

This chapter presents the results of this research. The research was carried out by conducting literature review of the previous studies on Underground Freight Transportation as well as a survey with freight transportation professionals in Texas. The participants answered various questions regarding the cost, challenges of UFT, construction methods, financing methods, etc.

5.2 Results of Literature Review

After reviewing the background and the worldwide studies about underground freight transportation it was concluded that UFT systems can be divided in two categories, underground automated vehicle systems and underground capsule pipelines. The main feature, which is common for both systems, is the underground automatic driverless system; however, underground freight pipelines are more desirable than the other method since in this system a self-propelled capsule with a linear induction motor (LIM) is used, which contributes to less fuel consumption that results in a more sustainable, more cost effective, and more environmental friendly transportation system.

In the first part of the literature review background, previous research on UFT was discussed as found in different countries such as, the Netherlands, U.S., Germany, and the UK. Several of these studies were conducted to determine the feasibility of UFT and the results were as follows:

- Underground freight transportation is not dependent upon above-ground traffic flow and elements. The underground route will be dedicated to UFT only; hence, goods will be delivered faster.
- The average failure of UFT is almost eight times less than that of trucks.

- UFT can help minimize congestion and traffic on highways.
- UFT reduces the amount of incidents such as car and truck accidents.
- Having UFT results in less fuel consumption which means it can increase air quality.
- The desirable power source for UFT is the linear induction motor, which has an electric power source that can be produced from green sources such as solar panels.
- UFT decreases noise pollution.
- Last but not least, the underground feature results in limited access to the freight protecting it from theft and accidents, which leads to a more secure freight transportation.

A review of the results shows that UFT is financially, technically, environmentally, and socially more beneficial than traditional transportation modes.

The focus on the second part of the literature review was on cost and construction issues. It is obvious that various parameters affect UFT cost. These parameters can be divided into seven major categories: geotechnical risks and subsurface determination, location, design, safety regulations, environmental regulations, contingency, and material/labor. In addition to the cost, another challenge that was discussed was the tunnel construction as the most challenging part of implementation. The main characteristic of the tunnel is to support the main transport mechanism that serves as the route to transport material while, being compatible with natural phenomenon such as ground water and danger of seepage as well as natural disasters such as earthquake.

Generally, tunnel construction can be divided in two categories: 1) Tunnel boring machine (TBM) used for trenchless construction and 2) the cut and cover method of

above ground construction. In TBM, large-diameter horizontal drills continuously excavate predominantly circular tunnel sections. This machinery powers the cutter head, hauls the spoils, and leads the TBM forward. The circular cutter head is mobilized with numerous steel bits, which cut rock, soil, or mixed materials as the cutter head rotates, producing a circular tunnel.

Cut and cover construction encompasses cutting the ground surface open and then backfilling over the surface once construction is complete. Cut and cover method always requires some excavation of the tunnel and station areas from the street surface which could result in rerouting traffic and causing delays for drivers and traffic jams. To have the most productive construction method it is suggested to combine the TBM method cost and cover.

Chapter 3 presents a research study on the feasibility of UFT in New York City conducted by Liu (2004) for the New York State Energy Research and Development Authority (NYSERDA). The objective of this research was to study the feasibility of using modern PCP technology for possible use in New York City for underground freight transportation as a means to reduce the City's reliance on trucks and to reduce the City's traffic-related problems. The major reason for this research was to address goods transportation in New York such as the prevention of loss in productivity caused by traffic congestion, to decrease the number of accidents, to conserve energy by reducing the amount of fuel used in transportation, improve the air quality, and last but not least, to enhance security and safety.

Finally, it was concluded that it is both technically and economically feasible to use the technology of pneumatic capsule pipeline (PCP) to transport freight in New York City. Applications of PCPs in New York City can bring great social and environmental

benefits to the City, derived from the reduced use of trucks in the City for freight transport.

5.3 Results of Survey

Survey results illustrated that underground freight transportation can be used as a complementary means of freight transportation in Texas. However, the majority of the survey participants felt that UFT can be part of intermodal freight transportation in the next 15 years. The survey highlighted the needs for more research on feasibility of UFT in costs, construction methods, and propulsion systems. According to Figure 4.2, 70 percent of the survey respondents believed that UFT is not cost effective and competitive with existing freight transportation methods such as railroad or trucks. However, the respondents did not consider the social, environmental, and safety costs of traditional freight transportation. Additionally, they were not asked to include all the costs of trucking, which is the major mode of transportation in Texas. In consideration of costs, such parameters as, road construction and maintenance, and impacts of truck traffic on road structure need to be considered. Therefore, conducting research on increasing cost effectiveness of UFT comparing with existing freight transportation methods in the state of Texas can enhance the feasibility of UFT.

As mentioned in previous chapters, Texas is expected to experience a significant population growth in next few decades, which will result in an increase in demand for freight transportation. In addition, the Panama Canal expansion project is expected to be completed by 2016 which will greatly increase freight transportation due to the import and export growth caused by a more accessible canal. According to Figure 4.11, the survey results indicated that the majority of survey participants ranked traffic reduction on highways and streets, increased traffic safety, increased reliability, reduction in damage

to pavement and reduction in fuel consumption among the most important benefits of UFT.

By analyzing the answers to the previous two questions regarding cost effectiveness of UFT and the benefits of UFT, it can be concluded that the public is aware of negative impacts of traditional transportation systems, but they may not be aware that these impacts could result in paying more for fuel, pavement maintenance, safety, etc., in the long-term. All of these problems can be resolved by UFT.

In this thesis, four proposed routes for construction of UFT in Texas as well as three UFT sizes (small, medium and large) were proposed. Proposed routes are the Port of Houston to a distribution center in Dallas, The border with Mexico at Laredo to a distribution center in Houston, the Port of Houston to a distribution center outside of Houston and the DFW airport to a distribution center within 10 miles. Based on the survey results, three routes were favored: 1) a large UFT system from the port of Houston to a distribution center in Dallas, 2) a large UFT from Port of Houston to a distribution center outside Houston, and 3) a small UFT from the DFW airport to a distribution center in DFW were chosen as the most appropriate options. These three options can facilitate transportation of freight containers in the mentioned routes.

As shown in Figure 4.5, among the four applicable UFT construction methods discussed in this survey, open-cut tunneling was selected as the most applicable UFT construction method followed by the tunnel boring method (a trenchless technology). On the other hand, constructability issues and space problems for open-cut construction were among the most challenging construction issues of UFT in Texas. A combination of construction methods can be used in construction of UFT in the aforementioned routes; however, trenchless or tunneling method using TBM is more appropriate for urban areas

due to less disruption to surface and existing pavement and open-cut tunneling can be used outside cities.

Finally, an issue for UFT in Texas, according to respondents, is the financing and construction delivery method. After analyzing the responses for the best financing method for UFT, Public Private Partnership (PPP) was preferred followed by Public-Public, public sector funding, and private sector funding, respectively. Design-build-operate-maintenance (DBOM) with 68% vote was selected as the best construction delivery method.

5.4 Chapter Summary

In this chapter, the results of the literature review and the Survey of Feasibility of UFT in Texas were discussed. The survey results indicated that respondents felt that UFT may not be a cost effective transportation system now, but definitely will be cost effective in 15 years. The overall benefits of UFT such as, sustainability, lower maintenance costs, safer and more reliable freight delivery, as well as a reduction in emissions and use of fossil fuel were among the parameters that caused survey respondents to prefer UFT when compared with other modes of transportation.

Chapter 6

Conclusions and Recommendations for Future Research

6.1 Conclusions

The conclusions of this thesis can be summarized as follows:

1. Due to expected population growth in Texas in the next few decades and as a result of a projected increase in freight transportation, underground freight transportation can be used as a complementary method of freight transportation.
2. Cost effectiveness is one of the most important factors to consider for UFT competitiveness with other freight transportation methods such as trucks or railroad, and once the infrastructure is established, UFT will pay for itself many times over due to low maintenance underground and reduced traffic aboveground, which will cut down on accidents and road repairs.
3. Results showed that container-size UFT with the dimensions of 10 ft × 10 ft × 50 ft for the Port of Houston to Dallas is the most appropriate compared to small and medium UFT sizes.
4. Public and Private Partnership (PPP) was the most desirable financing method for construction of UFT.
5. Design-build-operate-maintenance (DBOM) was the most appropriate delivery method for construction of underground freight transportation.
6. Tunnel construction is the most challenging element in construction of underground freight transportation.
7. Reducing traffic congestion and increasing highways safety are the most important benefits of UFT.
8. Among other benefits, UFT is more environmentally friendly than traditional modes of transportation.

6.2 Recommendations for Future Research

The recommendations for future research can be summarized as follows:

1. Conduct a detailed cost estimate on construction of UFT to facilitate cost comparison between UFT and existing modes of freight transportation.
2. Conduct an in-depth research to further develop the LIM system as the most effective propulsion method for transportation of large size containers.
3. Perform research to determine energy savings to transport each ton of freight over one mile of distance by UFT.
4. Perform laboratory tests to study technological advances of UFT.
5. Consider more routes in the state of Texas.
6. Improve public perception of UFT.
7. Conduct more studies and research on using green energies (such as wind and solar) as the power source to operate the UFT system.

Appendix A

List of Acronyms and Abbreviations

Abbreviations	Descriptions
ACP	Panama Canal Authority
BOT	Build Operation Transfer
CBP	Customs and Border Protection
DBOM	Design- Build- Operate- Maintenance
DBB	Design-Bid-Build
DB	Design-Build
EIA	Environmental Impact Assessment
EPBM	Earth Pressure Balance Machine
FSS	Freight Shuttle System
HCP	Hydraulic Capsule Pipeline
HGV	Heavy Goods Vehicle
LIM	Linear Induction Motor
NPV	Net Present Value
PCP	Pneumatic Capsule Pipeline
POE	Ports-of-Entry
PPP	Public Private Partnership
RFID	Radio Frequency Identification
TBM	Tunnel Boring Machine
UFT	Underground Freight Transportation
VMT	Vehicle Miles Traveled

Appendix B
Survey Questions

*** Question 1: Have you been involved in any Freight Transportation projects in any capacity in Texas?**

- Yes
- No

Question 2: Please specify your type of involvement with Freight Transportation in Texas:

- Contracting
- Engineering
- Planning
- Operating
- Regulating
- Other (please specify)

Question 3: Do you think that UFT will be cost effective and competitive with other modes of Freight Transportation in Texas, such as trucks and rail road?

- Yes
- No

Why or why not, please explain:

Question 4: Do you foresee UFT to be a part of an inter-modal Freight Transportation in Texas in (pick one):

- 5 Years
- 10 Years
- 15 Years
- 20 Years
- 40 Years

Please provide additional information in the box below:

Question 5: What method of construction is most applicable for an Underground Freight Transportation project in Texas. Please rank from 1 to 4, with 1 being the most and 4 being the least (Please see definitions below):

⋮	▾	Open-cut Tunneling
⋮	▾	Box Jacking
⋮	▾	Tunneling
⋮	▾	Pipe Jacking

Question 6: What are the most challenging problems for traditional modes of Freight Transportation (such as, truck, railroad, air, etc.)in Texas? Please respond in the box below:

Question 7: For the following, please rank from 1 to 5, with 1 being the least and 5 being the most challenges of UFT:

⋮	Availability of Funds
⋮	High Cost
⋮	Constructability Issues
⋮	Operational Problems
⋮	Lack of Government Support

Please provide additional information in the box below:

Question 8: Among the following, please rank from 1 to 10, with 1 being the least and 10 being the most obstacles for construction of UFT in Texas:

⋮	Existing Utility Relocation
⋮	Soil Conditions
⋮	Tunnel Construction
⋮	Open-cut Construction
⋮	Underground Water Control
⋮	Spoil Removal
⋮	Excavation Support
⋮	Easement Availability
⋮	Building Access Shafts During Tunnel Construction
⋮	Operation and Maintenance

Please provide additional information in the box below:

Question 9: What size of UFT is most effective. Please rank from 1 to 3, with 1 being the most and 3 being the least:

⋮	<input type="text"/>	Small - For small commodities, such as, mails, parcels, etc. (3 ft x 3 ft cross sections)
⋮	<input type="text"/>	Medium - For mini containers (5 ft x 5 ft x 12 ft)
⋮	<input type="text"/>	Large - For large containers (10 ft x 10 ft x 40 or 50 ft)

Please provide additional information in the box below:

Question 10: What size of UFT might be a good candidate for the routes listed below in Texas? Please rank from 1 to 3, with 1 being the most and 3 being the least:

	Small	Medium	Large
Port of Houston to a Distribution Center in Dallas	<input type="text"/>	<input type="text"/>	<input type="text"/>
Port of Houston to a Distribution Center outside of Houston	<input type="text"/>	<input type="text"/>	<input type="text"/>
The border with Mexico at Laredo to a Distribution Center in Houston	<input type="text"/>	<input type="text"/>	<input type="text"/>
DFW to a distribution center within 10 miles	<input type="text"/>	<input type="text"/>	<input type="text"/>

Please provide additional information in the box below:

Question 11: Please give us your suggestions for additional routes that might be a candidate for UFT in Texas.

Question 12: Among the following, please rank the benefits of UFT in Texas? Please rank from 1 to 9, with 1 being the most and 9 being the least:

⋮	⬇	Reducing Traffic Congestion
⋮	⬇	Increasing Reliability
⋮	⬇	Enhancing Highway Safety
⋮	⬇	Reducing Fuel Consumption
⋮	⬇	Reducing Noise and Dust
⋮	⬇	Better Design Life
⋮	⬇	Improving Freight Capacity
⋮	⬇	Improving Security
⋮	⬇	Reducing Damage to Pavement

Please provide additional information in the box below:

Question 13: What type of financing might be best suitable to construct and operate UFT in Texas? Please rank from 1 to 4, with 1 being the most and 4 being the least (Please see definitions below):

⋮	⬇	PPP
⋮	⬇	Public Public
⋮	⬇	Public
⋮	⬇	Private

Question 14: What type of delivery method might be best suitable to construct and operate UFT in Texas? Please select (Please see definitions below):

- Design-Bid-Build (DBB)
- Design-Build (DB)
- Design-Build-Operate-Maintain (DBOM)
- Build-Operate-Transfer (BOT)

Question 15: Please add any suggestions or comments you may have in the following box:

References

- ASCE. (2015). "Roads: Conditions and Capacity." Available at:
<<http://www.infrastructurereportcard.org/a/#p/roads/conditions-and-capacity>>
(Accessed on December 15, 2015).
- Cambridge Systematics, Inc. (2011) "Potential Effects of the Panama Canal Expansion on the Texas Transportation System." Center for Transportation Research (CTR) – University of Texas, October, 2011.
- CargoCap. (2015). "Freight Transportation in Congested Urban Areas." Available at:
<<http://www.cargocap.com/content/the-cargocap-system>> (Accessed on December 10, 2015).
- Crighton, G. S. (1992). "Tunnel Design and Construction." *Proc., Institution of Civil Engineers*, ISSN 0965-089X, E-ISSN 1751-7672.
- Efron, N., and Read, M. (2012). "Analyzing International Tunnel Costs, an Interactive Qualifying Project." Worcester Polytechnic Institute.
- Federal Transit Administration, and MTA New York City Transit, (2015). "Final Environmental Impact Statement (FEIS): New York Second Avenue Subway." Available at: <http://web.mta.info/capital/sas_docs/feis.htm> (Accessed on October 20, 2015).
- Foxx, A. (2015). "Beyond Traffic, Trends and Choice." Available at:
<https://www.transportation.gov/sites/dot.gov/files/docs/Draft_Beyond_Traffic_Framework.pdf> (Accessed on November 10, 2015).
- Frawley, W. E., Borowiec, J. D., Protopapas, A., Warner, J. E., Morgan, C. A. (2011). "Landside Freight Access to Airports—Challenges and Solutions." Texas Department of Transportation and the Federal Highway Administration, May 2011.

- Goff, A., Patil, S. and Shih, C. S. (1998). "Feasibility of Freight Pipelines to Relieve Highway Congestion." Texas Department of Transportation. Available at: <http://d2dtl5nnlpr0r.cloudfront.net/tti.tamu.edu/documents/1803-1.pdf> (Accessed on October 20, 2015).
- GRID Logistic Corporation. (2015). "Comprehensive Sustainable Freight Transportation." Available at: < <http://www.gridinc.biz/thegridproject> > (Accessed on December 20, 2015).
- Gurtoo, A., and Antony, S.J. (2007). "Environmental regulations: Indirect and unintended consequences on economy and business." *Management of Environmental Quality*, v 18, n 6.
- Harris, W. (2011). "How tunnels work." Available at: <http://science.howstuffworks.com/engineering/structural/tunnel.htm>, (Accessed on October 15, 2011).
- Hinze, J. (2008). "Construction safety." *Safety Science*, v 46, n 4.
- Hoek, E., and Brown, E. T. (1982). "Underground Excavations in Rock." *Support of Underground Excavation in Hard Rock*, Institution of Mining & Metallurgy, London, UK, ISBN 0900488-54-9.
- Khankarli, G. A., (2009). "The Politics of Public-Public Partnerships: The Case for Toll Roads." The University of Texas at Dallas.
- Kosugi, S. (2000). "A Capsule Pipeline System for Limestone Transportation," *Proc., 2000 Mid-Continent Transportation Symposium*.
- Kosugi, S. (1992). "A Capsule Pipeline System for Limestone Transportation." *Proc., 4th International Conference on Bulk Materials Storage, Handling and Transportation*, Wollongong, Australia.

- Lavagno, E., and Schranz, L. (2008). "Underground Freight Transportation in Urban Areas." *Proc., 5th International Symposium on Underground Freight Transportation by Capsule Pipelines and Other Tube/Tunnel systems*, The University of Texas at Arlington.
- Lenferin, S. (2009). "Government Strategies for Market Involvement in Road Infrastructure Planning: An International Overview." University of Groningen, Netherlands.
- Lieske, S. N. (2008). "Planning Decision Support—Australian Examples." Geodata Services, Inc., Missoula, Montana, USA.
- Liu, H. (2000). "Pneumatic Capsule Pipeline—Basic Concept, Practical Considerations, and Current Research." *Proc., 2000 Mid-Continent Transportation Symposium*, Iowa State University.
- Liu, H. (2004). "Feasibility of Underground Pneumatic Freight Transport in New York City." Final Report prepared for The New York State Energy Research and Development Authority (NYSERDA).
- Liu, H., and Lenau, C. (2008). "Pneumatic Capsule Pipeline (PCP): Recent Progress." *Proc., 5th International Symposium on Underground Freight Transportation by Capsule Pipelines and Other Tube/Tunnel systems*, University of Texas at Arlington.
- Miles, R., and Loose, B. (2008). "Sizing the Prize – Presenting the Case for Freight Pipelines." *Proc., 5th International Symposium on Underground Freight Transportation by Capsule Pipelines and Other Tube/Tunnel systems*, University of Texas at Arlington.
- Mouratidis, A. (2008). "The Cut-And-Cover and Cover-And-Cut Techniques in Highway Engineering." *1st Conference "Earthworks in Europe*, Paris, France.

- Najafi, M. (2013). "Trenchless Technology; Planning, Equipment, and Methods." New York: McGraw-Hill Companies.
- DFW Newsletter. (2015). <https://www.dfwairport.com/cargo/P1_008842.php> (Accessed on December 14, 2015).
- Parker, H. W. (1996). "Geotechnical Investigations." *Tunnel Engineering Handbook*, 2nd Ed, edited by Kuesel and King, Chapman & Hall., New York.
- Pells, P. (2002). "Developments in the Design of Tunnels and Caverns in the Triassic Rocks of the Sydney Region." *Rock Mechanics and Mining Sciences*, 39(5), 569-587.
- Pielage, B. J., and Rijsenbrij, J. (2005). *The Future of Automated Freight Transportation*, Edward Elgar Publishing., Boston, Massachusetts.
- Riegger, M. H., (2008). "Calculating The Annual Cost Of Labor: Setting Fees Correctly And Fine-Tuning Work Schedules Help Keep It In Line." *DVM Newsmagazine*, 39(7), 52.
- Roop, S.S., Olson, O., Warner, J., Morgan, C., and Rediniotis, O. (2000). "The Technical and Economic Feasibility of a Freight Pipeline System in Texas – Year 1 Report." Texas Department of Transportation Research and Technology Implementation, 1519-1.
- Roop, S. S., Aldrete, R., Bujanda. A., Fierro. K., Warner. J., Williams. J. (2011). "Freight Shuttle System: Cross-Border Movement of Goods." Texas Department of Transportation Research and Technology Implementation.
- Texas Freight Advisory Committee. (2015). "Freight Movement in Texas: Trends and Issues." Available at: <<http://ftp.dot.state.tx.us/pub/txdot-info/freight/white-papers/white-paper-freight-trends-and-issues.pdf>> (November 5, 2015).

- Touran, A. (2003). "Calculation of Contingency in Construction Projects." Northeastern University, Boston, Massachusetts, USA.
- Visser, J. and Binsbergen, A.J. (1997). "Underground Networks for Freight Transport: A Dedicated Infrastructure for Intermodal Short-Distance Freight." *Transport, Infrastructure and Logistics, New Times and Innovative Solutions Offered*, University of Delf, Netherland, October 30, 1997.
- Yu, L., Najafi, M., Liu, H. (2008). "Evaluation of Construction Cost of Underground Tunnels for Large Diameter Pneumatic Capsule Pipelines." Proc., 5th International Symposium on Underground Freight Transportation by Capsule Pipelines and Other Tube/ Tunnel Systems, The University of Texas at Arlington, Arlington, Texas, U.S.A.

Biographical Information

Seyedeh Hosna Mousavipour graduated in 2013 with a bachelor's degree in Architectural Engineering from Shiraz University in Iran. While studying, she worked as a project engineer on several projects for major cities as well as residential and commercial projects for one year. In January 2014, she entered the University of Texas at Arlington to pursue a Master's Degree in Civil Engineering with a focus in Construction Engineering and Management. She worked as a graduate research/teaching assistant under supervision of Dr. Mohammad Najafi at the Center for Underground Infrastructure Research and Education (CUIRE).

She is currently working as a project engineer at Criado & Associate, Inc. on infrastructure projects.