

CFD BASED DESIGN AND OPTIMIZATION OF LOUVER BLADE ANGLES TO
ENHANCE BETTER AIR FLOW DISTRIBUTION AND IMPROVE THERMAL
EFFICIENCY OF IT EQUIPMENT IN DATA CENTERS

By

AVINASH KUMAR RAY

Presented to the Faculty of the Graduate School of
The University of Texas at Arlington in Partial Fulfillment
of the Requirements
for the Degree of

MASTER OF SCIENCE IN MECHANICAL ENGINEERING

THE UNIVERSITY OF TEXAS AT ARLINGTON

May 2016

Copyright © by Avinash Kumar Ray 2016

All Rights Reserved



Acknowledgements

I would like to take this opportunity to express my sincerest gratitude to my supervising professor Dr. Derejee Agonafer for his prodigious support, guidance and encouragement throughout the course of my research work. The invaluable advice and timely support whenever required was the major driving force, which enabled me to complete my research work.

I would like to thank Dr. Abdolhossein Haji Sheikh and Dr. Miguel A Amaya for taking their time for serving as my committee members. I would also like to take this opportunity to thank Mr. Mike Kaler, Mr. Naveen Kannan and Mr. James Hoverson of Mestex for all their expertise and continuous support and feedback during the projects. Their industrial expertise has been really important for my research. Also I would like to thank Dr. Betsegaw Gebrehiwot, Devi Prasad Gorrepati and other lab mates for their invaluable support while working at the EMNSPC labs.

I would like to thank Ms. Debi Barton and Ms. Sally Thompson for being very kind and helpful throughout my administrative work and educational matters at all times.

I would like to thank all my friends in the EMNSPC team and my roommates who constantly supported me throughout my time here. Lastly, I would like to thank my parents Mr. Ashok and Mrs. Asha, my brother Mr. Venkatesh, my sister Ms. Bhavani for their support both emotionally and financially, without which I would not have been able to dream this far. I would also like to thank my best friend Ms. Navya for her advice and support. I owe my love and gratitude to god almighty for giving me strength and keeping me motivated.

April 15, 2016

ABSTRACT

CFD BASED DESIGN AND OPTIMIZATION OF LOUVER BLADE ANGLES TO ENHANCE BETTER AIR FLOW DISTRIBUTION AND IMPROVE THERMAL EFFICIENCY OF IT EQUIPMENT IN DATA CENTERS

Avinash Kumar Ray, MS

The University of Texas at Arlington, 2016

Supervising Professor: Derejee Agonafer

A data center is a depository which stores, processes and distribute large amounts of data and information using computer systems and associated components for power supplies, cooling systems. Modular data center is a portable method of deploying traditional large data center capacity into a small portable unit. According to the Uptime Institute, the amount of heat generated inside IT equipment has been increasing significantly. Data centers are using nearly 60% of their power in employing expensive cooling techniques. In addition, the cost of cooling has necessitated a need to reduce or eliminate mechanical cooling. As such, Air Economization, Direct and Indirect evaporative cooling techniques are effective methods for extending free cooling. These cooling techniques can only be efficient when coupled with proper air flow management inside the data center. The air handling unit is responsible to distribute the conditioned air inside the data center. The air from cooling unit is passed into the IT Pod through a set of angled slats or fixed strips hung at regular intervals called Louvers.

Louvers are very essential and basic components of any HVAC systems. It is often overlooked or not given due importance while designing. Poor air flow management can cause air recirculation in the cold aisle creating a low pressure region. The fans

inside the servers have to draw air and cool the IT after overcoming this negative pressure differential which in turn makes the fan to draw less amount of air than specified. This causes insufficient cooling of the IT equipment and thereby increasing the amount of heat generated inside the servers.

These Louver blades are adjustable, placed inside duct entries to regulate the flow of air. The air flow distribution inside the data center should be optimum with minimum air recirculation. The amount of air flow inside the data center is regulated by the free area of a Louver. The orientation of Louver blades gives the air flow pattern in the data center. These two factors are very crucial while designing and selecting a Louver as they have a significant impact on its performance. The focus of this study is to characterize the air flow pattern with the appropriate Louver orientation and thus provide sufficient amount of air passed into the IT pod with minimum air recirculation. The air from the cooling unit can only be fully utilized when it is followed by proper air flow management inside the data center. This reduces the heat generated in the IT equipment and thereby increases its efficiency and reliability which saves significant amount of energy and cost involved in the cooling applications.

The study was done in collaboration with industrial partner and results have been verified and adopted.

TABLE OF CONTENTS

Acknowledgements	iii
ABSTRACT	iv
LIST OF TABLES	xiii
CHAPTER 1 INTRODUCITON TO MODULAR DATA CENTERS	15
1.1 Data Centers.....	15
1.1.2 Power trends in Data centers	16
1.2 ASHRAE Recommendations.....	17
1.3 Modular Data Centers	18
1.3.1 Modular data centers: Introduction.....	18
1.3.2 Classification of Modular data centers :	19
1.3.3 Advantages of modular data center	21
1.3.4 Modular Data Centers vs. Traditional Data centers [15]	22
1.3.5 First generation Modular Data Center	24
1.3.6 Second Generation Modular Data Center	24
1.4 Use of cooling methods in Data centers.....	25
CHAPTER 2 INTRODUCTION TO FREE COOLING AND EVAPORATIVE COOLING.....	26
2.1 Air Side Economization	26
2.1 Introduction to Evaporative Cooling	27
2.2 Types of Evaporative Cooling	28
2.2.1 Direct Evaporative Cooling	28
2.2.2 Indirect Evaporative Cooling	29
2.2.3 Direct/Indirect evaporative cooling.....	30
2.3 Advantages of Evaporative cooling	31

2.4 Disadvantages of Evaporative cooling	31
CHAPTER 3 AIR HANDLING UNIT AND LOUVERS	32
3.1 INTRODUCTION TO AIR HANDLING UNITS	32
3.2 INTRODUCTION TO LOUVERS	33
3.3 IMPORTANCE OF LOUVERS	34
3.4 Types of Louvers	35
3.4.1 Drainable louvers.....	35
3.4.2 Non Drainable louvers.....	35
3.4.3 Hurricane Louver	36
3.4.4 Acoustic Louver	36
3.4.5 Operating Louver.....	37
3.4.6 Miscellaneous Louver.....	37
3.4.7 Brick/ Block Louver.....	38
3.4.8 Dual Combination Blades Louver (Drainable).....	38
3.5 Criteria for Selecting a Louver	39
3.5.1 Free Area.....	39
3.5.2 Water Penetration:.....	40
3.5.3 Resistance to Air flow:.....	40
3.6 Importance of Louvers.....	41
CHAPTER 4 COMPUTATIONAL FLUID DYNAMICS	42
4.1 Introduction to CFD Analysis	42
4.2 Governing Equations	43
4.3 Computational Solution Domain	43
4.4 Turbulence Modeling	45
4.4.1 LEVEL Turbulence Model.....	46

4.4.2 K-Epsilon Turbulence Model	46
4.5 Grid Constants and Meshing	47
4.6 Smart Parts in FloTHERM	47
4.6.1 Cuboid	47
4.6.2 Resistance	48
4.6.3 Enclosure	48
4.6.4 Source	48
4.6.5 Monitor Points	48
4.6.6 Region	48
4.6.7 Command Center	49
4.6.8 Sloping Blocks	49
4.6.8.1 System Curve Characteristics	49
4.6.8.2 Fan Curve Characteristics	50
4.6.9 Rack	51
CHAPTER 5 DESCRIPTION OF THE CFD MODEL	52
5.1 Description of the Modular Data Center	52
5.2 Description of the CFD Model	53
5.2.1 Dimensions of the IT Pod	53
5.2.2 Description of Louver setup	55
5.2.3 Model Setup	56
5.3 Meshing	56
5.4 Scenarios Considered	58
5.4.1 First Scenario:	58
5.4.2 Second Scenario:	59
5.4.3 Third Scenario:	59

CHAPTER 6 RESULTS AND DISCUSSIONS.....	60
6.1 Zero degree angle (Baseline) Results.....	60
6.1.1 Thermal contour in IT pod.....	61
6.1.2 Air flow Distribution in the IT pod.....	63
6.2 Case study 15 degree angle.....	64
6.2.1 Thermal Contour in IT pod.....	64
6.2.2 Air flow Distribution inside IT pod.....	65
6.3 Case study 25 degree angle:.....	66
6.3.1 Thermal Contour in the IT Pod.....	66
6.3.2 Air flow Distribution inside IT pod.....	68
6.4 Case study 35 degree angle.....	69
6.4.1 Thermal Contour in the IT Pod.....	69
6.4.2 Air flow Distribution inside IT pod.....	71
6.5 Case study 45 degree angle.....	71
6.5.1 Thermal Contour in the IT Pod.....	72
6.5.2 Air flow Distribution inside IT pod.....	73
6.6 II set of blade spacing Results.....	76
6.6.1 Comparison between the I and II set of spacing.....	77
6.7 Vertical louver arrangement.....	78
CHAPTER 7 RECOMMENDATIONS AND FUTURE WORK.....	79
7.1 Recommendations.....	79
7.2 Future Work.....	80
REFERENCES.....	81
BIOGRAPHICAL INFORMATION.....	83

LIST OF ILLUSTRATIONS

Figure 1 Amazon data center [1].....	15
Figure 2 Energy Break down in a Data center [2].....	16
Figure 3 Psychometric chart showing various zones recommended by ASHRAE [5].....	17
Figure 4 HP modular data center.....	19
Figure 5 Mestex Modular data center	20
Figure 6 Commscope Modular data center.....	21
Figure 7 HP POD	24
Figure 8 Ice Cube Air Modular Data Center Using Air-Side Economizer Cooling	25
Figure 9 Hours with Ideal conditions for an air-side economizer operation [7].....	27
Figure 10 CAD model of Louver	33
Figure 11 Different shapes of Louvers [16].....	33
Figure 12 Air Intake louver in front of vehicles.....	34
Figure 13 Inlet Louver in cooling unit.....	34
Figure 14 Drainable Louver [3]	35
Figure 15 Non - Drainable Louver [3].....	35
Figure 16 Hurricane Louver [3]	36
Figure 17 Acoustic Louver [3]	36
Figure 18 Operating Louver [3]	37
Figure 19 Miscellaneous Louver [3].....	37
Figure 20 Brick Louver	38
Figure 21 Louvers Free area	39
Figure 22 Water penetration in Louvers.....	40
Figure 23 Resistance to air flow.....	41
Figure 24 Representation of 3-D grid.....	44
Figure 25 System Curve	50

Figure 26 Fan Curve	50
Figure 27 Representation of smart rack option in FloTHERM	51
Figure 28 Data center facility	52
Figure 29: (a) CFD model of the IT Pod (b) Cold aisle and hot aisle.....	53
Figure 30 Server Cabinets inside the IT pod	54
Figure 31 Servers stacked inside cabinet	54
Figure 32 Server stacked front view	54
Figure 33 Louver Setup.....	55
Figure 34 Mesh generated Top View	57
Figure 35 Mesh Front view	57
Figure 36 Mesh side view	57
Figure 37 Side view of the Louver setup varying the orientation from 0 ° to 45	58
Figure 38 Showing the variation in No. of blades	59
Figure 39 Vertical arrangement of louver blades	59
Figure 40 Inlet Louver at 0 degree orientation	60
Figure 41 Thermal contour for 0 degree	61
Figure 42 Temperature distribution across the racks	62
Figure 43 Particle trace of air flow for 0 degree case	63
Figure 44 Inlet louvers at 15 degree case.....	64
Figure 45 Thermal contour for 15 degree case	64
Figure 46 Temperature distribution across server racks	65
Figure 47 Air flow pattern for 15 degree case.....	65
Figure 48 Inlet louvers at 25 degrees	66
Figure 49 Thermal profile of IT pod for 25 degree case	67
Figure 50 Temperature distribution across server racks	68

Figure 51 Air flow pattern for 25 degree case.....	68
Figure 52 Inlet louvers at 35 degrees	69
Figure 53 Thermal profile of IT pod for 35 degree case	70
Figure 54 Temperature distribution across server racks	70
Figure 55 Air flow pattern for 35 degree case.....	71
Figure 56 Inlet louvers at 45 degrees	71
Figure 57 Thermal profile of IT pod for 35 degree case	72
Figure 58 Temperature distribution across server racks	73
Figure 59 Air flow pattern for 45 degree case.....	73
Figure 60 Temperature distribution across server racks for different louver orientation ..	74
Figure 61 Flow rate through server racks for different orientations	75
Figure 62 Temperature distribution across server racks for II set of blade spacing	76
Figure 63 Comparison of Temperature distribution between I and II set for 0 degree	77
Figure 64 Comparison of Temperature distribution between I and II set for 45 degree ...	77
Figure 65 Vertical louver arrangement.....	78
Figure 66 Comparison chart among I set II set and Vertical louver case	78

LIST OF TABLES

Table 1 Modular Data center Vs Tradiitonal Data Center	22
Table 2: Dimensions of the IT Pod.....	53
Table 3: Dimensions of the Louver arrangement.....	55

NOMENCLATURE

ρ	Density (kg/m ³)
k	Thermal Conductivity (W/m-K)
ϵ	Kinematic Rate of Dissipation (m ² /s ³)
v	Velocity (m/s)
μ	Viscosity (N/m ² s)
\dot{m}	Mass flow rate (kg/s)
q	Heat load (W)
P	Power (W)
\dot{v}	Volumetric Flow Rate (cfm)
IT	Information Technology

ASHRAE American Society of Heating, Refrigeration and Air Conditioning
Engineers

Re	Reynolds number
C_p	Specific Heat capacity (J/kg K)
p	Pressure (in of H ₂ O)
DEC	Direct Evaporative Cooling Unit
IEC	Indirect Evaporative Cooling Unit

CHAPTER 1

INTRODUCITON TO MODULAR DATA CENTERS

1.1 Data Centers

A data center is a huge depository that is used to store IT equipment such as servers and computer systems and other electronic equipment. These data centers are responsible for functions like storage, processing, manage and interchange of data and information. The ever increasing need for networking and internet usage for basic activities such as payment of utility bills, shopping, fund transfer and travel booking lead to the data centers to be seemingly ubiquitous. Moreover we observe with the usage of telecommunications, banking, stock markets, social networks, educational institutions, search engines the need for data centers are prominently increasing day by day. The IT equipment inside the data centers has to perform all these functions. Therefore the size of the data centers and power utilized by the facility has also increased considerably.



Figure 1 Amazon data center [1]

The heat dissipated by the IT equipment increases with the amount of work load. These conventional data centers employ complex power distribution and expensive cooling systems to cool the IT equipment. These relatively expensive cooling systems can underperform their full capacity and can be inefficient.

1.1.2 Power trends in Data centers

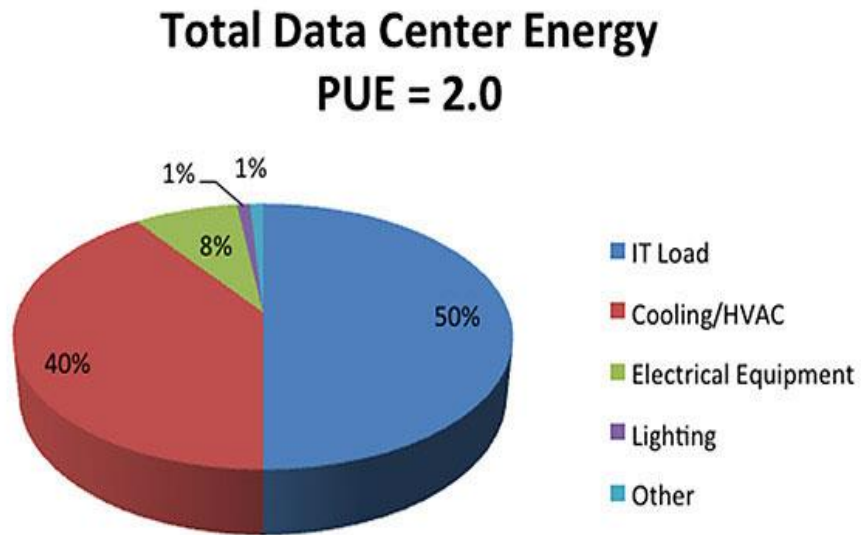

Figure 2 Energy Break down in a Data center [2]

It is estimated that nearly 12 million computer servers in nearly 3 million data centers deliver all U.S online activities. These data centers consume enough electricity to power all of New York households for about 2 years. [1].

The above figure illustrates the energy break down within a data center. It can be seen that 50% of the total power is consumed by the IT equipment and another 40% of the total power goes in cooling these equipment

This trend is likely to increase every year. So there is a need for designing energy efficient data centers.

1.2 ASHRAE Recommendations

The American society of Heating, Refrigeration and Air conditioning Engineers (ASHRAE) recommended certain thermal guidelines for the safe operations of IT equipment in data centers. Earlier to these guidelines, the IT manufacturer used to provide recommendations on the operation of their product in data center environment which is not accurate due to diversity of usage of equipment in a data center [1].

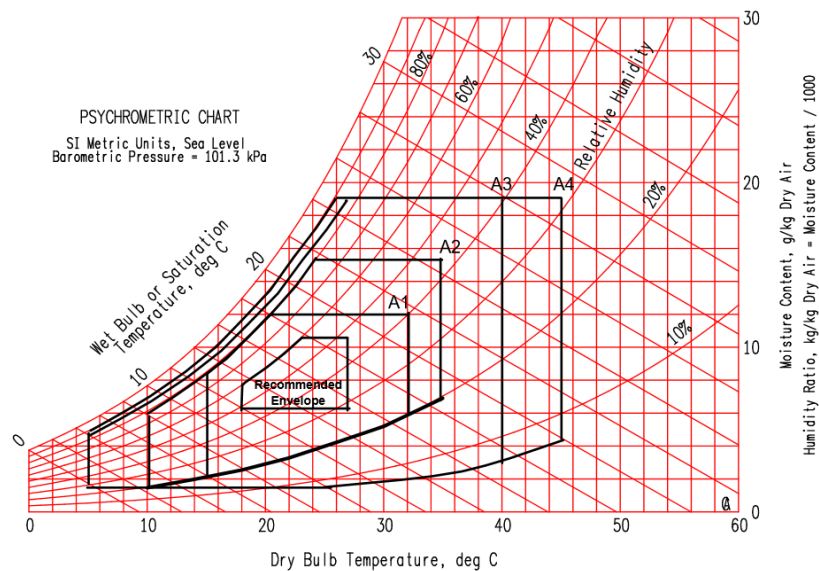

Figure 3 Psychrometric chart showing various zones recommended by ASHRAE [5]

The TC 9.9 expanded the environmental range in order to allow data center operators to operate in the most energy efficient mode and achieve the required reliability for the IT equipment.

ASHRAE class A3 gives allowable window for temperature range to 41°F to 113 °F while moisture range extends from 8% RH and 10.4 °F dew point temperature to 90% RH.

ASHRAE class A4 gives the allowable temperature range from 41 °F to 113 °F while the moisture range extends from 8% RH and 10.4°F dew point temperature to 90 % RH.

The recommended class extends from dry bulb temperatures 64.4°F to 80.6°F, with humidity range from 41.9°F dew point to 60 % RH and 59°F dew point temperature [6]

1.3 Modular Data Centers

1.3.1 Modular data centers: Introduction

The conventional data centers are expanding in terms of size and power density with rapid advancement of technology and networking. Therefore, the investment to set up high capacity data centers has also increased so as the additional costs for construction and maintenance. Expansion of traditional, large data centers is difficult unless it is accounted earlier before construction. Expansion in terms of capacity is also considerably difficult as systems have to be ordered, shipped and delivered to the data center where they must be racked and installed. The process would require skilled labor in addition to cost of shipping and delivering the system. [3]

Therefore the need for energy efficient modules that can save money and reduce electricity is necessary. This motivated to start the use of Modular data center.

Modular data centers are portable way of deploying the traditional large data center capacity into small portable units. Modular data centers are energy efficient modules designed for rapid deployment, energy efficiency and better computing density.

They are group of integrated pre-engineered and pre-fabricated modular blocks that need to be transported to a customer's site and assembled to provide the required payload capacities and equipped with proper cooling and power distribution facilities.

The first modular data center known as Project Black box was introduced by Sun Microsystems (now known as Oracle Corporation). It consists of a portable data center of standard 20 feet shipping container which requires power supply and an external chiller to be operated. It was equipped with around 280 servers. Since then the use of Modular data centers rose to prominence

1.3.2 Classification of Modular data centers :

Modular data centers comes under two types of form factors.



Figure 4 HP modular data center

- a. The First type is called Containerized data centers or portable modular data center as it ships its entire IT equipment like servers, storage and networking equipment into a standard shipping container called Intermodal container. This container helps to transport the equipment to desired locations. Containerized data centers typically come equipped with their own cooling systems.
- b. The second type of modular data center fits its equipment into a facility consists of prefabricated components which can be built on site and can be added to the capacity later as per the requirement.



Figure 5 Mestex Modular data center

The main difference between a modular data center and traditional data center is that in traditional data center the equipment structures and sheets are bought first and then fabricated at its backyard while , in modular data center the parts are already pre-fabricated and can be readily shed procured readily at the backyard and can be used readily. [6]

1.3.3 Advantages of modular data center

The advantages of modular data centers over traditional data center can be seen below

1. The reliability and veracity of the modules present inside can be modified as per the required efficiency.
2. The airflow inside the air handling units can be modified for better performance and efficiency.
3. The tight management of set points and inlet temperatures recorded inside the devices helps in reducing the energy required for cooling substantially.
4. Modular data centers are 60% faster to deploy as compared to that of a traditional data center.
5. They are energy efficient and require less maintenance compared to traditional data centers.



Figure 6 Commscope Modular data center

These modular data centers have gained great importance with time because of their simplicity and the ease at which it can be deployed.

Modular data centers are having faster computing ability at a lower cost when compared to traditional data centers and are more energy efficient can be deployed at a faster rate. The differences between modular data center and traditional data center can be summarized in the table below.

1.3.4 Modular Data Centers vs. Traditional Data centers [15]

Table 1 Modular Data center Vs Traditional Data Center

Sr. No.	Factor	Traditional data center build out	Facility module
1	Time to deploy	12 to 24 months represents a typical timeframe Can be designed, delivered, installed, and operational within	8 months or less
2	Cost to deploy	High up front capital cost with extensive field assembly, installation, and integration	Allows data center to be built out in large kW building blocks of pre-manufactured power and cooling capacity
3	Regulatory roadblocks	Regulatory approvals on an ad-hoc basis for the various steps of the infrastructure layout. This approach often results in delays that impact the initiation of downstream construction. The end user is responsible for securing approvals.	Data center owners who choose to install facility modules should check with local authorities prior to installation. Permitting processes may vary greatly across different geographies.
4	Security	Physical security is enhanced when assets are located deep within the building, away from the outside perimeter	Location of physical infrastructure assets outside of the building increases exposure to outside physical security and weather threats

5	Installation	From a physical infrastructure perspective, a retrofit can be more complex and more invasive than a build out of a new data Center.	Specialized equipment (such as a crane) is needed to maneuver 20 and 40 foot pre-configured facility modules.
6	Tax implications	Recognized as permanent part of the building	Temporary structure which can be more attractive from a tax perspective
7	Reliability	The solution is assembled on site from various parts and pieces provided by multiple vendors. This increases the need for coordination and therefore, creates more chances for human error.	More predictable performance because components are prewired and are factory acceptance tested before shipping. Smaller modules reduce risks of human error:
8	Efficiency	Existing structures often limit the electrical efficiencies that can be achieved through optimized power and cooling distribution; complex custom configured controls often result in suboptimal cooling operation, reducing efficiency.	Facility modules can utilize standard modular internal components and can be specified to a target PUE.
9	Carbon footprint	Construction materials utilized are high in carbon emissions. Brick, insulation and concrete are all carbon emission intensive materials. Concrete is often used for floors, walls and ceilings.	Steel and aluminum produce about half the carbon emissions of concrete. Concrete is only used to pour a support pad. Significantly less concrete is needed for facility modules as opposed to a comparable "building shell" data center.
10	Serviceability	Traditional data centers have more room for service people to maneuver.	Servicing is more limited with facility modules because of space constraints

1.3.5 First generation Modular Data Center

First generation modular data centers are those facilities that require chiller water systems or refrigerant cooling coils as cooling units and can utilize direct expansion cooling units. These require direct expansion cooling units in which compressors and condensers are located outside the container.



Figure 7 HP POD

1.3.6 Second Generation Modular Data Center

Second generation modular data centers do not require chiller systems or direct expansion cooling. These systems use free cooling techniques such as evaporative cooling which is a highly efficient technique is sometimes paired with free air cooling when ambient air temperature reduction is required. These systems may also include

chilled water or direct expansion cooling units as a backup when the use of economizers may not cool outside air temperature.



Figure 8 Ice Cube Air Modular Data Center Using Air-Side Economizer Cooling

1.4 Use of cooling methods in Data centers

Unlike the cooling systems involved in traditional data centers which required compression and expansion of the refrigerant. The modular data centers use outside free air with the help of ASHRAE recommendations. The cooling techniques used by modular data centers are

1. Air-Side Economization
2. Direct Evaporative Cooling
3. Indirect Evaporative Cooling
4. Indirect / Direct Evaporative Cooling

CHAPTER 2

INTRODUCTION TO FREE COOLING AND EVAPORATIVE COOLING

2.1 Air Side Economization

Air side economization is a mechanism which is used to regulate the use of outside air for cooling. These are the most commonly used cooling systems. Air economizers are used to supply the cold air from outside into the data center through ducts. The sensors are used to monitor the temperature of outside and inside air conditions. If the external conditions are favorable for use of fresh outside air for cooling purpose, then economizers adjust the position of dampers through a control system to allow fresh air into the facility as a primary source of cooling. As air passes through the ducts, it is filtered to remove excess dust and contaminants. The filtered air is circulated across the portion of server racks that needs to be cooled and the hot air is exhausted out. If there is an excess amount of air into the system while driving fresh air then exhaust dampers maintain the pressure by driving out extra amount of air. If the external temperature is cooler than required then the dampers allow a portion of return air to mix with the cold air outside which is either recirculated or exhausted back outside. In this way air side economizers reduce the use of air conditioning units and chilled water systems.

Studying the ambient air conditions is very important to use air-side economizer technique. If the ambient air is dry though at lesser temperature the cooling system have to spend excessive energy humidifying the air. Similarly if the ambient air is too humid than required then system have to use dehumidifiers to remove excess humidity.

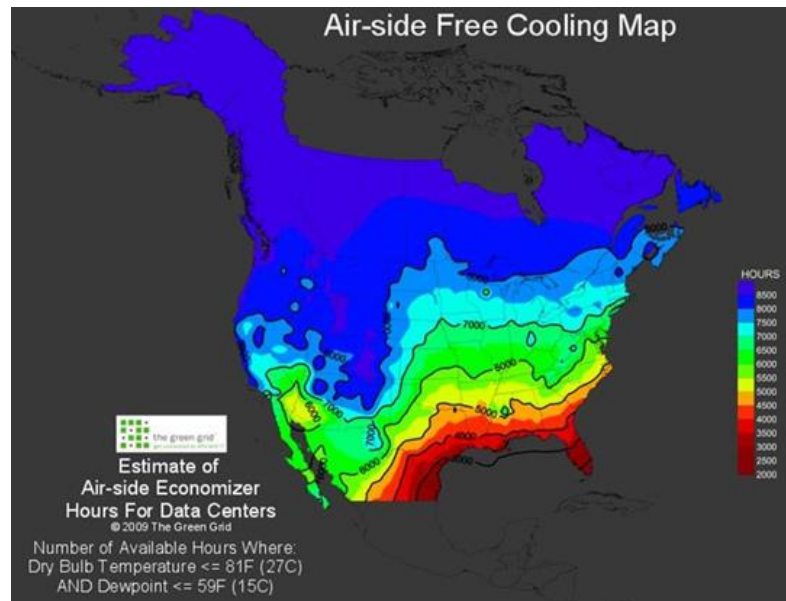

Figure 9 Hours with Ideal conditions for an air-side economizer operation [7]

2.1 Introduction to Evaporative Cooling

Cooling through evaporation technique is a naturally occurring process. The principle behind evaporative cooling is the use of heat to change from liquid to vapor. As a result heat is absorbed from the water remaining in liquid state making it a cooler liquid. [7]

Conventional cooling systems require high initial and operating cost and operate on refrigeration cycle. In arid areas where traditional cooling system can be avoided by using evaporative cooling techniques. It is also known as mist cooling, spray cooling or evaporative cooling. In typical air conditioning systems, which use vapor- compression or absorption refrigeration cycles which require a huge initial capital whereas in evaporative cooling methods naturally occurring process is used without any huge investment.

The molecules of liquid located near the surface evaporate by moving in proper direction and possess sufficient kinetic energy to overcome the liquid-phase

intermolecular forces. Only a small proportion of molecules located near the surface meet these criteria making the rate of evaporation to be limited. Kinetic energy is a property that depends directly on temperature hence the evaporation rate increases with increase in temperature. As the surface molecules evaporate and escape from the surface at a higher rate leaving back the rest of molecules travelling at a slower rate having less kinetic energy and therefore decreases the temperature of liquid. This is the basic working principle of evaporative cooling. [8]

2.2 Types of Evaporative Cooling

There are basically two types of evaporative cooling systems, direct evaporative cooling and indirect evaporative cooling.

2.2.1 Direct Evaporative Cooling

In direct evaporative cooling method, the air from outside is blown into water saturated medium and is cooled using evaporation. A blower is used to circulate this cooled air inside the unit. This cooling method adds moisture to the air until it reaches its saturation point. Dry bulb temperature is reduced while keeping the wet bulb temperature constant. These systems are used in home and industries. These are economical because it costs about half of traditional vapor compression system and consume one fourth of energy.

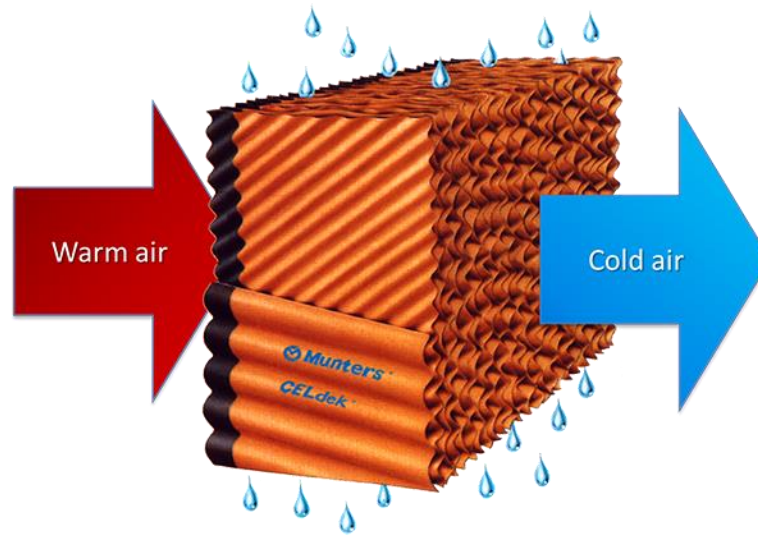

Fig 1.6 Direct Evaporative Cooling [2]

2.2.2 Indirect Evaporative Cooling

In indirect evaporative cooling, a secondary air stream is cooled using water and is passed through a heat exchanger where it helps to cool the primary air stream from the direct evaporative cooling method. Now the cooled air is circulated using blower. In this method moisture is not added to the primary air stream. Dry bulb and wet bulb temperatures are reduced. The sequential explanation of indirect evaporative cooling system is explained below [7].

1. Hot outside air is blown through a heat exchanger that is supplied with water. One design for this type of heat exchanger features a series of metal tubes that are kept wet on their outside surfaces. As hot air passes over these tubes, the water evaporates and the tubes are cooled. After passing over the tubes, the cool, moist air is exhausted to the outside.
2. As cooling happens on the heat exchanger's exterior surfaces, hot exterior air is drawn through the tube interiors. This air is cooled, but

without gaining any extra humidity, before it is blown through ductwork to the building interior.

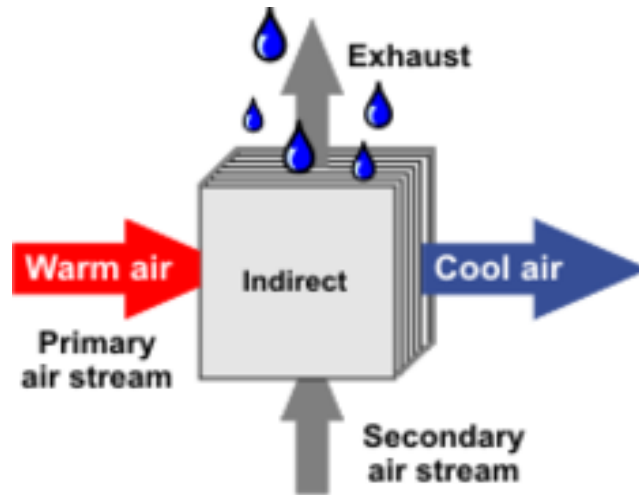

Fig 1.6 Indirect Evaporative Cooling [2]

2.2.3 Direct/Indirect evaporative cooling

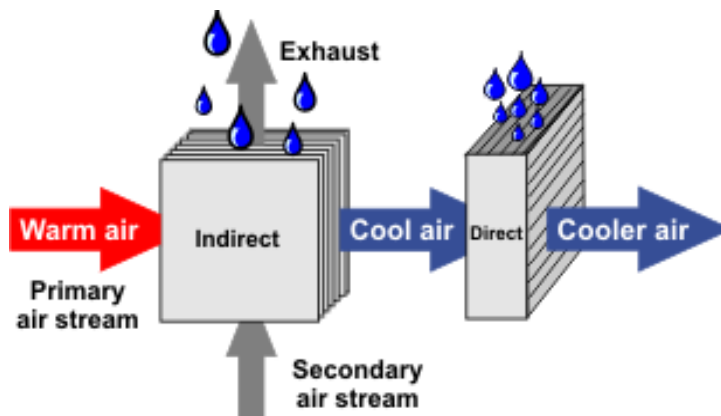

Fig 1.6 Indirect/Direct Evaporative Cooling [2]

This uses the combination of both direct and indirect evaporative cooling techniques. The primary air stream is cooled using indirect evaporative cooling and then it is passed into direct evaporative cooling unit where it is further cooled.

2.3 Advantages of Evaporative cooling

1. The use of Evaporative cooling is economical and helps in cutting down cost when compared to conventional refrigerant based AC system.
2. It adds moisture to dry air which helps in dry climatic regions.
3. It is suitable to be used in hot and dry climates.

2.4 Disadvantages of Evaporative cooling

1. This process continually consumes water throughout its working.
2. It adds humidity to the intake air while too much humidity is not good for the components present inside. It should be dehumidified regularly.
3. Regular maintenance is required in this process.
4. Evaporative cooling method is not suitable for regions where the climate is hot humid type.

With the ever increasing usage of power data centers have to come up with the usage of free air cooling to save significant amount of energy employed in huge cooling infrastructures. Depending upon the nature of outside air and the requirement inside the IT Pod, Modular data centers use the combination of the above mentioned cooling methods.

CHAPTER 3

AIR HANDLING UNIT AND LOUVERS

3.1 INTRODUCTION TO AIR HANDLING UNITS

An air handler, or air handling unit (AHU), is a device used to regulate and circulate air as part of a heating, ventilating, and air-conditioning (HVAC) system [8]. The air handler is usually a large metal box connects to a ductwork, ventilation system that distributes the conditioned air throughout the building and returns it to the AHU. The return duct from the IT pod forms as supply duct to the AHU and the supply duct to the IT pod acts as the AHU output. There are various components of AHU from the return duct, through the unit, to the supply duct.

The components include

1. Filters,
2. Heating or cooling element,
3. Humidifiers,
4. Mixing chambers
5. Blower fans and
6. Dampers and Louvers.

Air from the cooling unit is effective only when we use this cooled air properly through proper orientation of Inlet louvers.

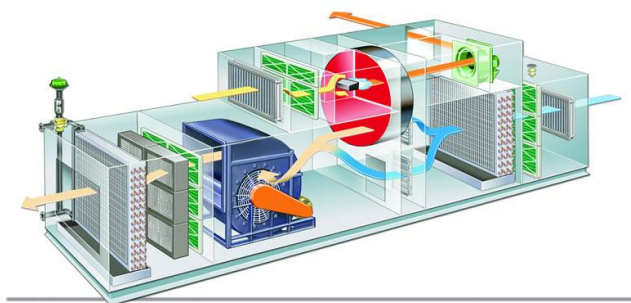

Figure 10 Air handling unit [10]

3.2 INTRODUCTION TO LOUVERS

Louvers were originally used in olden days as a ventilation product that were fitted on top of roof holes in kitchen that allows air, sunlight to pass through it while keeping out unwanted elements such as water, dirt, and debris. Now -a-days louvers are also used as aesthetics of a building apart from its functionality.

They are a set of angled slats or fixed strips hung at regular intervals. They are the essential and basic components of an HVAC system.

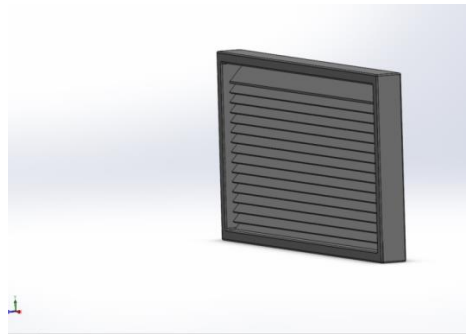

Figure 11 CAD model of Louver

Louvers come in a variety of shapes and sizes according to the requirement in the industry or in daily life. Based on the type of application required the Louvers are designed and manufactured in various appearances like line vertical, horizontal or often with mullions and provided with vertical, horizontal or inverted blades



Figure 12 Different shapes of Louvers [16]

3.3 IMPORTANCE OF LOUVERS

Louvers are used not only as a common primary design element in modern architecture but also as technical device. They are used in industrial facilities such as steel foundries and power plants as a source for natural ventilation and temperature control. They can be used as a type of flood opening designed in such a way to allow flood waters to enter and leave the facility thereby mitigating structural damage to the building. They are also used as a means of thermal control on spacecraft, mounted as an accessory for automobiles. They are primarily used in cooling systems of high capacity data centers



Figure 13 Air Intake louver in front of vehicles

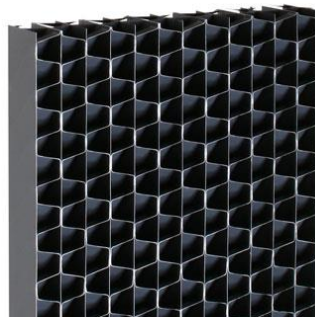

Figure 14 Inlet Louver in cooling unit

3.4 Types of Louvers

3.4.1 *Drainable louvers*

Drainable blade louvers feature a specially constructed edge gutter and downspout in each blade. Falling water is drained to the jambs, removing cascading water droplets from the air stream. Drainable blades are highly recommended for use in applications where water penetration and air performance are most critical. These louvers allow very low water penetration with extremely high free area. [2]



Figure 15 Drainable Louver [3]

3.4.2 *Non Drainable louvers*

These Non drainable louvers should be used in applications where water penetration is low and ventilation is important.



Figure 16 Non - Drainable Louver [3]

3.4.3 Hurricane Louver



Figure 17 Hurricane Louver [3]

3.4.4 Acoustic Louver

These louvers are designed in such a way that reduces the intensity of sound while allowing air.



Figure 18 Acoustic Louver [3]

3.4.5 Operating Louver

Operable louvers control the amount of air through a louver available with different operable blade angle. [3]



Figure 19 Operating Louver [3]

3.4.6 Miscellaneous Louver

These louvers are used in pent houses that require huge flow of air and intake units that prevent entry of undesirable elements



Figure 20 Miscellaneous Louver [3]

3.4.7 Brick/ Block Louver

These louvers are used in air conditioning intake units, heating rooms. These are ideal for crawl space, between floor and exhaust.



Figure 21 Brick Louver

3.4.8 Dual Combination Blades Louver (Drainable)

This louver is a combination of both fixed and adjustable blades in a single frame. The advantage of this louver is that it provides control over the air flow keeping the exterior appearance to be constant.

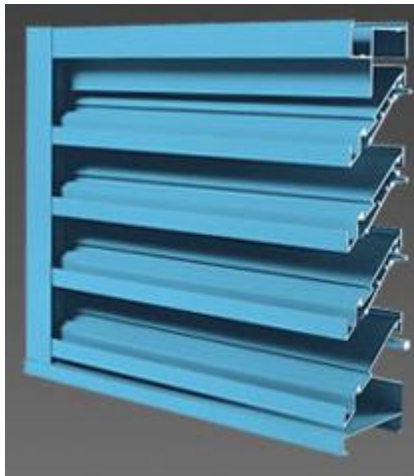

Figure 20 Dual Combination Louver [13]

3.5 Criteria for Selecting a Louver

The basic considerations for selecting a louver are

1. Free area
2. Water penetration
3. Resistance to air flow (Pressure drop)

3.5.1 Free Area

Free area is defined as the total minimum area available for the air to flow through a louver after removing all kinds of hindrances to the flow.

It is obtained by taking the total open area of the louver after subtracting all the obstructions from the blades and frames and dividing with the overall wall opening.

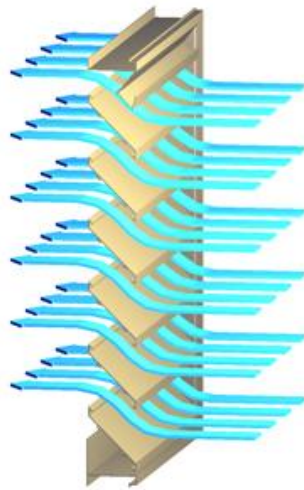

Figure 22 Louvers Free area

3.5.2 Water Penetration:

The water penetrates in some proportions into the louver while allowing the air intake due to rainfall, winds. An efficient louver should maximize its free area while allowing minimum amount of water entering through it. First point of water penetration is the point at which a louver allows the passage of water through it. It is the air intake velocity at which louver will begin leaking. It is measured in feet per minute (fpm).

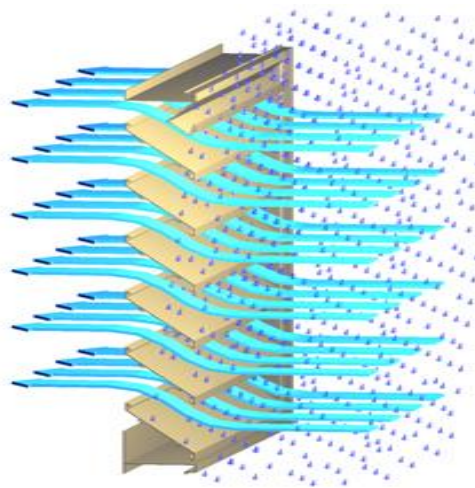

Figure 23 Water penetration in Louvers

3.5.3 Resistance to Air flow:

Every obstruction in the air flow creates the resistance from the louvers, mullions, coils, ducts, building structure and filters etc. Resistance of the louver is measured by running air through it and measuring the pressure differential at different free area velocities. The pressure losses are calculated for different louver shape and determine if it is acceptable. The air flow distribution plays an important role in the thermal management. The resistance created should provide the adequate air flow

without causing them to be detrimental to server fans and equipment inside. The hurdles to air flow can be reduced by lowering the blade angles of the louver and making the stream line flow.

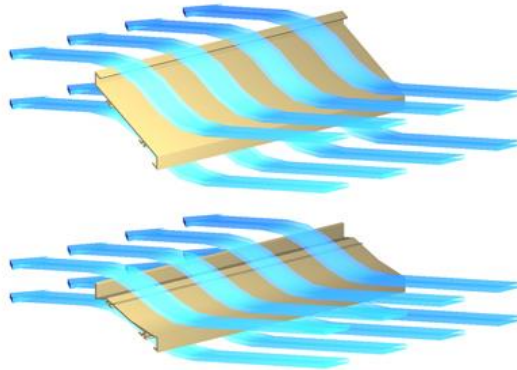

Figure 24 Resistance to air flow

3.6 Importance of Louvers

Louvers are important to allow air into a building, keeping undesirable elements like rain, water, dirt and debris. They are essential for any Heating, Ventilating and Air Conditioning (HVAC) systems. In the present scenario the energy is becoming scarce and the sources are diminishing drastically. Industries employ expensive cooling units and consume more power to cool the air and components. The air from the cooling unit is passed into the industries using air handling unit. The air from cooling unit is effective only when we use the cooled air from cooling unit is properly ventilated and circulated inside the data center.

The Louvers add as the extra element of aesthetic design to a building exterior. They are used in various shapes and sizes and predominantly enhance the aesthetics of a building design. The usage of Eco-friendly louvers should be made available and developed for using efficiently in cooling and refrigerating systems across the world.

CHAPTER 4

COMPUTATIONAL FLUID DYNAMICS

4.1 Introduction to CFD Analysis

Computational fluid dynamics (CFD) is a branch of fluid dynamics which deals with the numerical analysis inside systems related to fluid flow and heat transfer. It uses algorithms to solve the problems involving heat transfer characteristics and pressure characteristics. Computational fluid dynamics is applied to simulate and analyze the nature of fluids in various systems. The main use of this numerical method is that the problem is discretized based on a set of numerical parameters and solved. The CFD simulation tool has varied features such as grid generation, mesh sensitivity analysis and several other features. A numerical simulation is used for the generation of a mathematical model which represents the actual physical model to be analyzed and solved. In this case, the study involves detail CFD model of IT modules inside the data center along with server systems, power source, server fans. The CFD tool provides us the study involves effect of fluid (air) from the cooling unit inside the IT pod with the orientation of louver blades.

CFD is concerned with numerical simulation of fluid flow, heat transfer and radiation. The objective of CFD is to provide the engineer with a computer-based predictive tool that enables the analysis of air flow processes occurring within and around different electronic equipment. CFD analysis is very important for various applications such as data center industries, automobile industries and several more industries which involve turbulence with the aim of improving and optimizing the design of the new or existing equipment.

4.2 Governing Equations

The numerical solution for most problems involving heat transfer and fluid flow is obtained by solving series of three differential equations. These differential equations are collectively called Navier - Stokes' Equations. These differential equations are the conservation of mass, conservation of momentum and conservation of energy

In this particular case, the effect of flow on server temperature is analyzed.

For a generalized case,

The conservation of mass is given by:

$$\frac{\partial(\rho)}{\partial t} + \nabla \cdot (\rho u) = 0$$

The conservation of momentum is given by:

$$(\rho u) \partial t + (\rho u \cdot \nabla) u = \nabla \cdot (\mu \nabla u) - \nabla p + \rho f$$

The conservation of energy is given by:

$$\frac{\partial(\rho i)}{\partial t} + \nabla(\rho i u) = -p \nabla u + \nabla(k \nabla \cdot T) + \Phi + S i$$

4.3 Computational Solution Domain

The solution domain is the region or space defined within which these thermodynamic differential equations are solved. The solutions are obtained by imposing certain boundary conditions for this solution domain. The boundary conditions for most problems include ambient temperature, pressure, wind conditions and other environmental conditions. If there is a heat transfer involved then, type of heat transfer, such as conduction, convection or even radiation are considered. In addition the conditions at the domain wall are also has to be specified, whether they are open, closed or symmetrical in nature. The fluid properties like density, viscosity, diffusivity and specific

heat need to be specified. The conservation equations and the specified boundary conditions are solved first by numerical integration. First the solution domain is to be discretized with finite volume grid cells. The accuracy of the solution depends on the number of grid cells. When we increase the number of grid cells the computational time also increases. The governing equations for many CFD problems are solved using numerical techniques like Finite Element Method, Finite Volume Method, and Finite Difference Method. In FEM, the elements are varied and approximated by a function, in FVM the equations are integrated around a mesh element whose volumes are considered and in FDM the differential terms are discretized for each element.

In this particular case the computational code considered for numerical analysis in FloTHERM is the finite volume method where the solution is discretized around into large number of grid cells called control volume regions. So, the governing equations are solved by considering these control volume regions and the variables are calculated at the centroid of these finite volume.

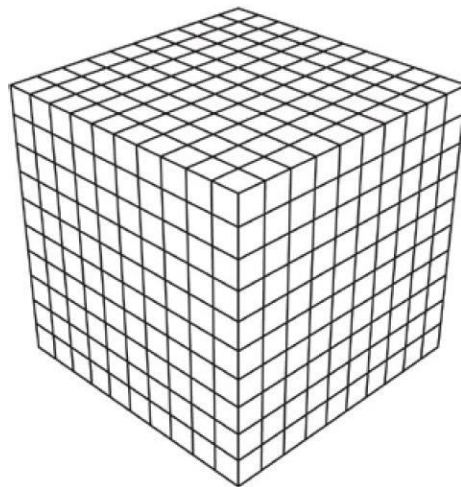

Figure 25 Representation of 3-D grid

The finite volume method for solving the governing equations mentioned above is more advantageous than other computational methods as it does not limit to a cell shape. It solves even on coarse grids. A set of algebraic equations are used for discretizing the results, each relating to a value of variable in a cell to its value in the nearest-neighbor cells.

For example, let T denote the temperature, this can be calculated using the algebraic equation:

$$T = \frac{C_0T_0 + C_1T_1 + C_2T_2 + \dots + C_nT_n + S}{C_0 + C_1 + C_2 + C_3 + \dots + C_n}$$

Where T_0 represents temperature value in the initial cell, T_1, T_2, \dots, T_n is valued in the neighboring cells; $C_0, C_1, C_2, \dots, C_n$ are the coefficients that link the in-cell value to each of its neighbor-cell values. S denotes the terms that represent the influences of the boundary conditions.

These algebraic equations are solved for the variables like $T, u, v, w,$ and p . This means that if there are 'n' cells in the solution domain, a total of 'Sn' equations are solved

4.4 Turbulence Modeling

A flow is called turbulent if the fluid undergoes irregular fluctuations or mixing. The velocity of the fluid at any point is continuously changing in both magnitude and direction where as in laminar flow the fluid moves in smooth paths or layers. Fluids with large Reynolds number are considered to be turbulent, while fluids with low Reynolds number are laminar. FloTHERM uses two common methods to solve turbulent flows: LEVEL turbulence model and K-Epsilon turbulence model.

4.4.1 LVEL Turbulence Model

This is a simple algebraic turbulence model that does not require solution of any partial differential equations. The model calculates nearest wall distance (L), the local velocity (VEL) and the laminar viscosity to determine the effective viscosity

In this model, Poisson's equation is solved initially to calculate the maximum length scale and local distance to the nearest wall.

$$D = \sqrt{(|\nabla\phi|^2 + 2\phi)}$$

$$L = D - |\nabla\phi|$$

Where $|\nabla\phi|^2 = -1$ and $\phi = 0$ (which is boundary condition at the wall)

ϕ is the dependent variable

4.4.2 K-Epsilon Turbulence Model

The K-Epsilon model solves the governing equations along with another two additional equations namely, the Kinetic energy of turbulence (k) and rate of dissipation of kinetic energy of turbulence (ε). It is commonly known as two equation model and is primarily used to model turbulence flow. The additional two transport equations solved are:

Kinetic Energy of turbulence equation (k)

$$\frac{\partial}{\partial t}(\rho k) + \text{div}\left[\frac{\mu}{\sigma k} \text{grad } k\right] + 2\mu E_{ij}E_{ij} - \rho\varepsilon$$

Dissipation rate of kinetic energy of turbulence (ε)

$$\frac{\partial}{\partial t}(\rho\varepsilon) + \text{div}(\rho\varepsilon U) = \text{div}\left[\frac{\mu}{\sigma} \text{grad } \varepsilon\right] + C \frac{\varepsilon}{k} 2\mu E_{ij}E_{ij} - C\rho \frac{\varepsilon^2}{k}$$

4.5 Grid Constants and Meshing

Grid constraints allow attaching minimum grid requirements to a given geometry so as to make sure sufficient grid coverage wherever it is located in the solution. Grid constraints are used for specifying minimum and maximum number of cells across the geometry. As discussed before, FloTHERM uses a Cartesian grid and the value for pressure and temperature is calculated at each cell center. Grid key points appear when components are created in FloTHERM.

Meshing is an important aspect in any CFD software, since if the model created is not properly meshed, the results of the simulation would be wrong. Therefore the mesh needs to be fine in critical areas of turbulence and can be made coarse where there is less important or laminar regions. Mesh sensitivity analysis can determine when the solution has reached grid independence. Grid independence is defined as the point at which the addition of large number of grid cells has no effect on the solution. Grid independence can significantly reduce computational time while meshing in FloTHERM there is an option to keep the grid fine, medium or coarse. Moreover localizing the mesh around an object is another option to improve the mesh and helps to truncate lines along the edges and disappear.

4.6 Smart Parts in FloTHERM

4.6.1 *Cuboid*

This smart part is the most basic part in FloTHERM. It is used to represent most of the objects in the system. It is a solid block and is used to represent any solid object like external structure of a modular data center, solid wall. This smart part can also be collapsed to represent a thin plate.

4.6.2 Resistance

Resistance smart part is used to create a region of resistance to flow. They can be created as collapsed, angled or non-collapsed depending on the requirement in the model. They can be used to create system resistance curve inside a server by giving loss coefficient. The loss coefficient should be determined in a way to represent the calculated pressure drop.

4.6.3 Enclosure

Enclosure smart part is a hollow part which is used to define the outer boundaries of a system. It represents a cuboidal shape with each side of it representing independent sides of an object or system. We can use some sides as per our convenience and remove the rest. The enclosure also gives an option of representing thickness of the wall. Ambient conditions can also be attached to this smart part.

4.6.4 Source

Heat sources or objects that require power to be defined can be represented using this source smart part. This smart part can be used to compute temperature, pressure and velocity over a planar or volumetric region in the given solution domain.

4.6.5 Monitor Points

Monitor point smart part is used to observe the fluctuations in temperature, pressure. Monitor points have no dimensions and are treated as a part of geometry. They also help to prevent any mistakes in modelling.

4.6.6 Region

The region smart part is used while post processing object included around the object of interest. It is used in two ways. Firstly it is used to create a refined region of mesh in a particular area of interest. Secondly it can be used for recording minimum, maximum and mean values of temperature, pressure and velocity of an object.

4.6.7 Command Center

The Command center in FloTHERM is used to solve and generate different scenarios simultaneously. Any changes to model are performed using input variables window. This helps us to vary multiple parameters and see their combined or individual effect on the system.

Basically, the procedure that is followed while using the command center is that a datum case is loaded as the project. Then in the command center, the parameters that are to be varied, called as the Input Variables are selected. This generates the different scenarios based on the number cases created. There is a graphical input tab which enables us to view what changes have occurred in the model, due to the scenarios created by the input variables defined. The results that are required, for example, pressure, temperature, velocity, speed, etc. can be selected in the Output Variables tab. These can be viewed in the Scenario Table generated along with the input variables as well. There is also a tab called Solution Monitoring, for monitoring the solution and check for convergence.

4.6.8 Sloping Blocks

Sloping block smart part is basically a cuboid with cross section on diagonal. They are modelled as smooth and non-conducting solids. Thermal properties, grid constraints can be attached to the sloping block. It is be noted that the grids should be made available on the cut section.

4.6.8.1 System Curve Characteristics

The system characteristics are represented in form of system curve. It is used to measure the resistance or impedance offered by a system. It represents the sum of total static pressure losses inside a system. It can be shown as a function of free area ratio and pressure drop across the object. System resistance changes with change in

geometry. For our case the resistance curve for 0 degree louver angle case is different from 45 degree louver orientation.

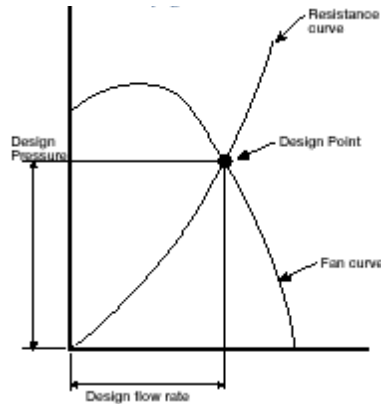

Figure 26 System Curve

4.6.8.2 Fan Curve Characteristics

Fan curve gives the relationship between the static pressure and volume flow rate of a particular fan. The operating point is a point of intersection of flow curve and system resistance curve. By calculating the point of operation the power required to rotate the fan can be calculated.

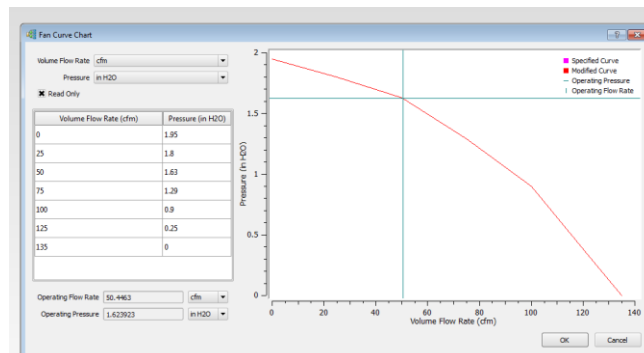

Figure 27 Fan Curve

4.6.9 Rack

Rack smart part helps to create server rack within a cabinet. It consists of extract and supply. In this smart part power dissipation and volume flow rate of air can be defined. The flow rate can be given either as a function of power dissipated or as a function of change in temperature or direct value of flow rate or using a fan curve.

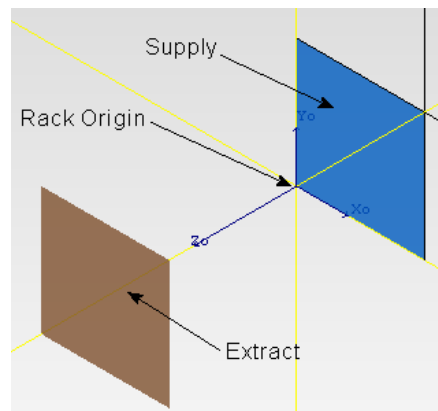

Figure 28 Representation of smart rack option in FloTHERM

CHAPTER 5

DESCRIPTION OF THE CFD MODEL

The Computational model is of Modular data center with detailed model of its interior including the server racks, air handling unit (louvers), cold aisle and hot aisle is modelled. Only the IT pod of the data center is modelled as this study is concerned with the effect of louver orientation on the thermal efficiency of servers. The model was entirely created using FloTHERM 10.1 smart parts.

5.1 Description of the Modular Data Center



Figure 29 Data center facility

The above figure shows the actual modular data center facility at Mestex. It consists of the IT pod attached with cooling unit with the help of air handling units. The IT pod consists of cold aisle and hot aisle separated by server cabinets

5.2 Description of the CFD Model

5.2.1 Dimensions of the IT Pod

Table 2: Dimensions of the IT Pod

IT Pod	Dimensions
Length	118.5217
Width (in)	106
Height (in)	138.5001

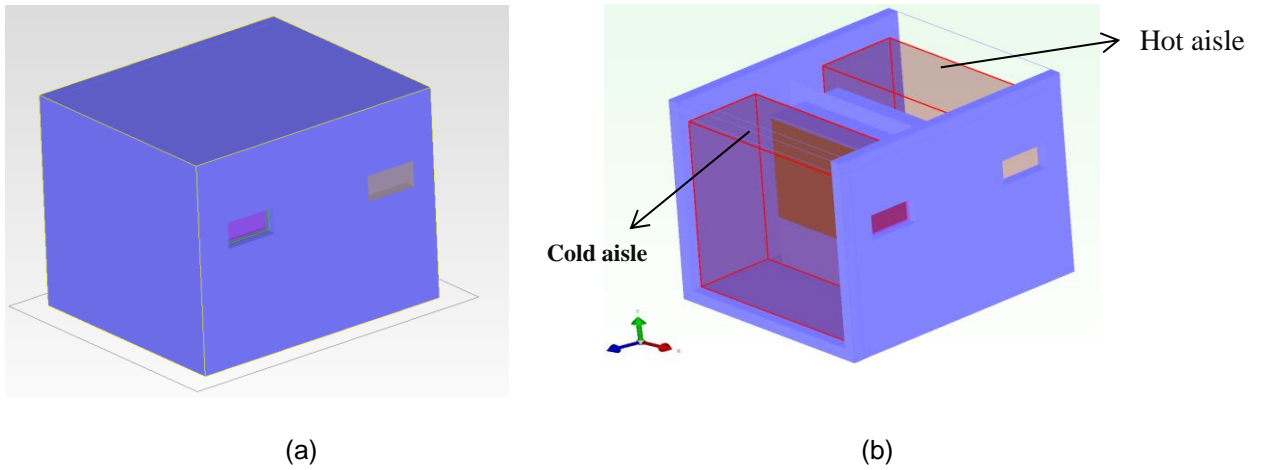

Figure 30: (a) CFD model of the IT Pod (b) Cold aisle and hot aisle

The CFD model of the IT pod was created in FloTHERM 10.1. The model consists of Cold aisle and hot aisle arrangement.

The inlet diffuser at inlet of cold aisle and exhaust dampers in hot aisle were modelled. The CFD Model depicts the detailed server racks with cabinets inside.

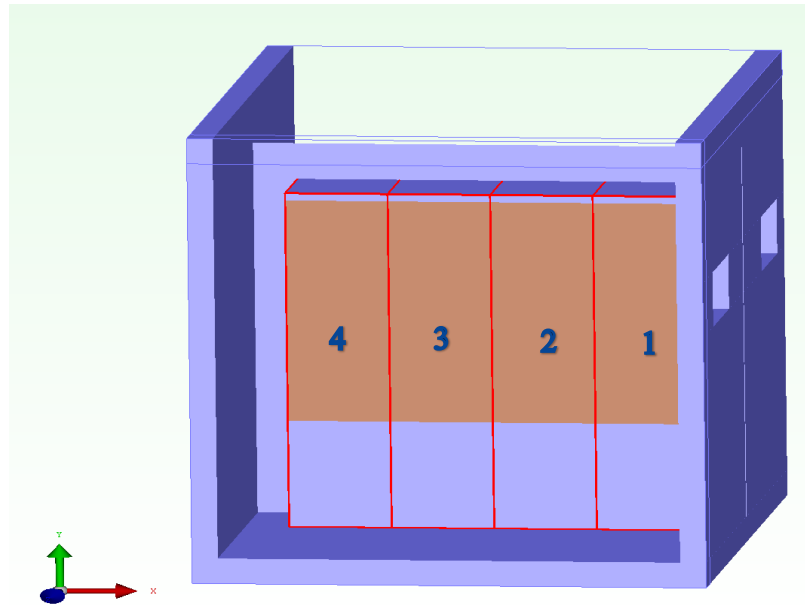

Figure 31 Server Cabinets inside the IT pod

There are four Cabinets racks of servers modeled. The servers represented were of model HP SE1102. The CFD model has blanking panels in between separating the aisles and to represent perfect containment and prevent back flow in between the aisles.

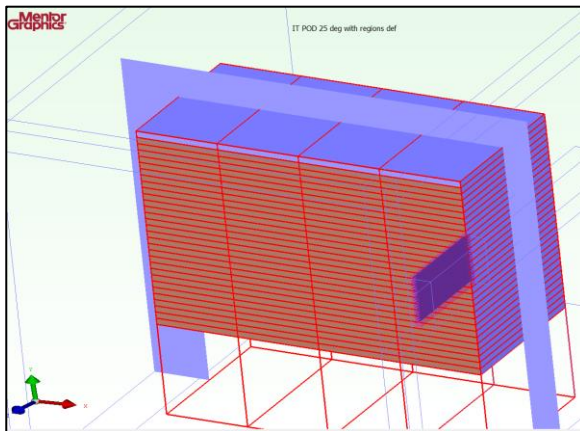

Figure 32 Servers stacked inside cabinet

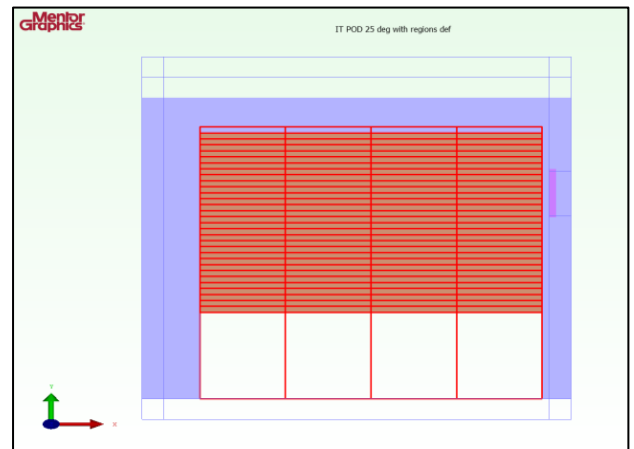

Figure 33 Server stacked front view

5.2.2 Description of Louver setup

The CFD model of the louvers setup was used for all the cases was as follows:

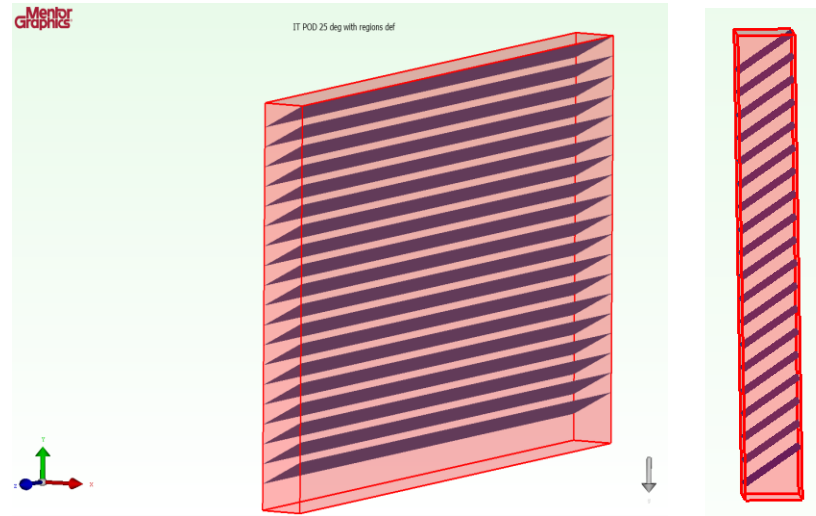

Figure 34 Louver Setup

Table 3: Dimensions of the Louver arrangement

Louvers	Dimensions
Length (in)	27
Width (in)	13
No. of Louver Blades	19

5.2.3 Model Setup

The model setup used for all the cases was as follows:

1. Type of Solution: Flow and Heat transfer
2. Dimensionality: 3-Dimensional
3. Gravity was set to normal, acting in –Y direction.
4. The flow type used was turbulent and LEVEL K- Epsilon turbulence model was used.
5. Ambient pressure: 1 Atm.
6. The radiant and ambient temperature was set to 35 °C
7. The inflow at the louver entrance was set to 6000 cfm.

5.3 Meshing

A quadrilateral mesh was generated to represent the fluid inside the domain. The mesh was created in such a way that it was made very fine in some regions where turbulence is expected and flow properties can be observed. The meshing has been the same for different scenarios considered for the results.

The meshing is dense. There are around 5 million cells and maximum aspect ratio of the CFD model is 9. The mesh is made finer in the regions where more turbulence is expected. The computational time is high due to high density of mesh. Grid independence study was also studied to validate the results from the CFD model.

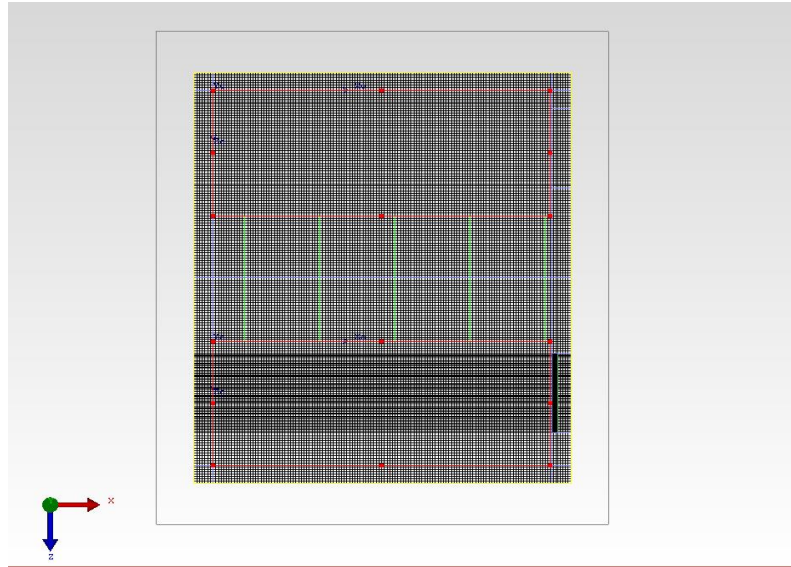

Figure 35 Mesh generated Top View

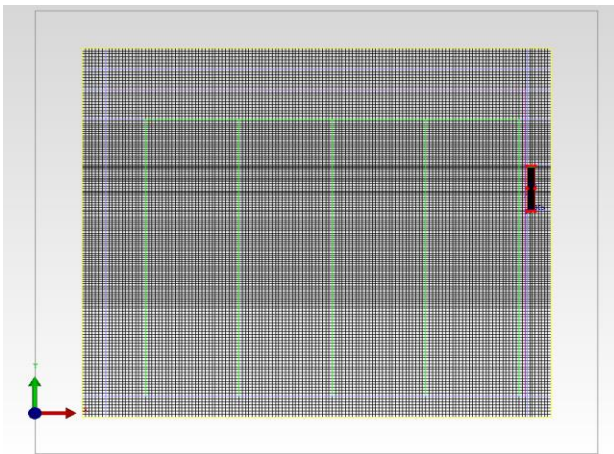

Figure 37 Mesh side view

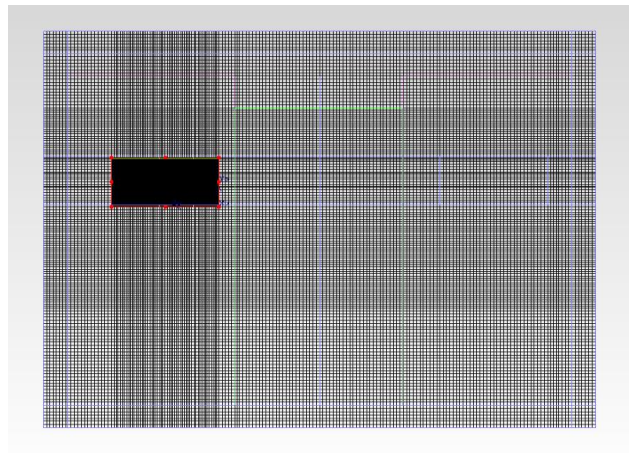

Figure 36 Mesh Front view

5.4 Scenarios Considered

The scenarios considered for the air flow pattern inside the IT pod was varying the louver blade angles from 0° to 45° and varying the number of blades from 19 to 10. The spacing between the louvers were varied from 0.68" to 1.4"

5.4.1 First Scenario:

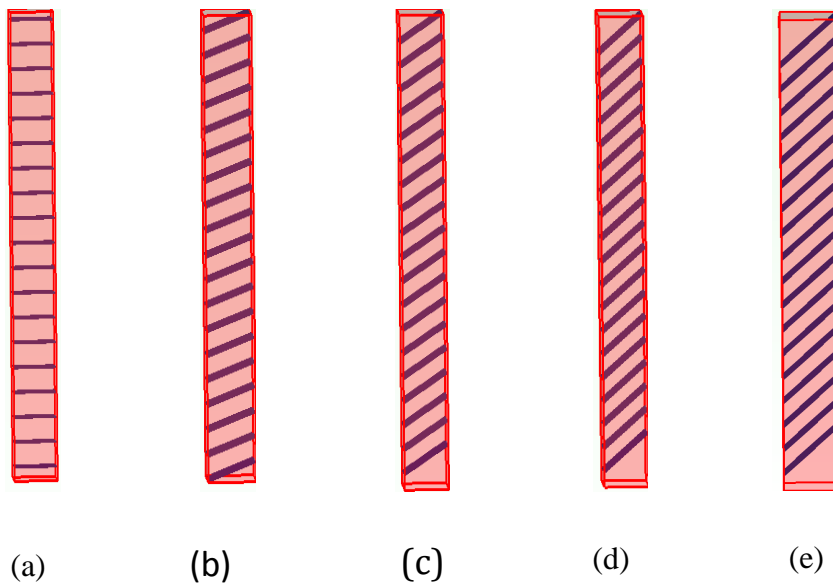

Figure 38 Side view of the Louver setup varying the orientation from 0° to 45°

5.4.2 Second Scenario:

The second scenario considered for the air flow pattern inside the IT pod was varying the number of blades from 19 to 10. The spacing between the louvers were varied from 0.68" to 1.4"

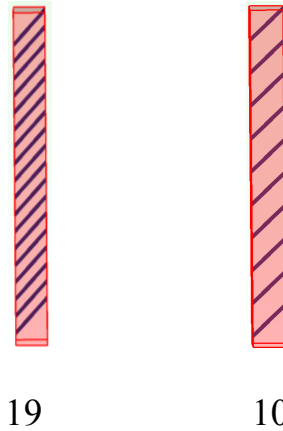

Figure 39 Showing the variation in No. of blades

5.4.3 Third Scenario:

The third scenario considered for the air flow pattern inside the IT pod was vertical arrangement of louver blades oriented at 15° towards the server cabinets.



Figure 40 Vertical arrangement of louver blades

CHAPTER 6
RESULTS AND DISCUSSIONS

6.1 Zero degree angle (Baseline) Results

Zero degree louver angle case is the baseline case. The inlet louver angles are at 0 degrees for the inlet louvers. The impact of air recirculation in the IT module and thermal contour has been studied and plotted.

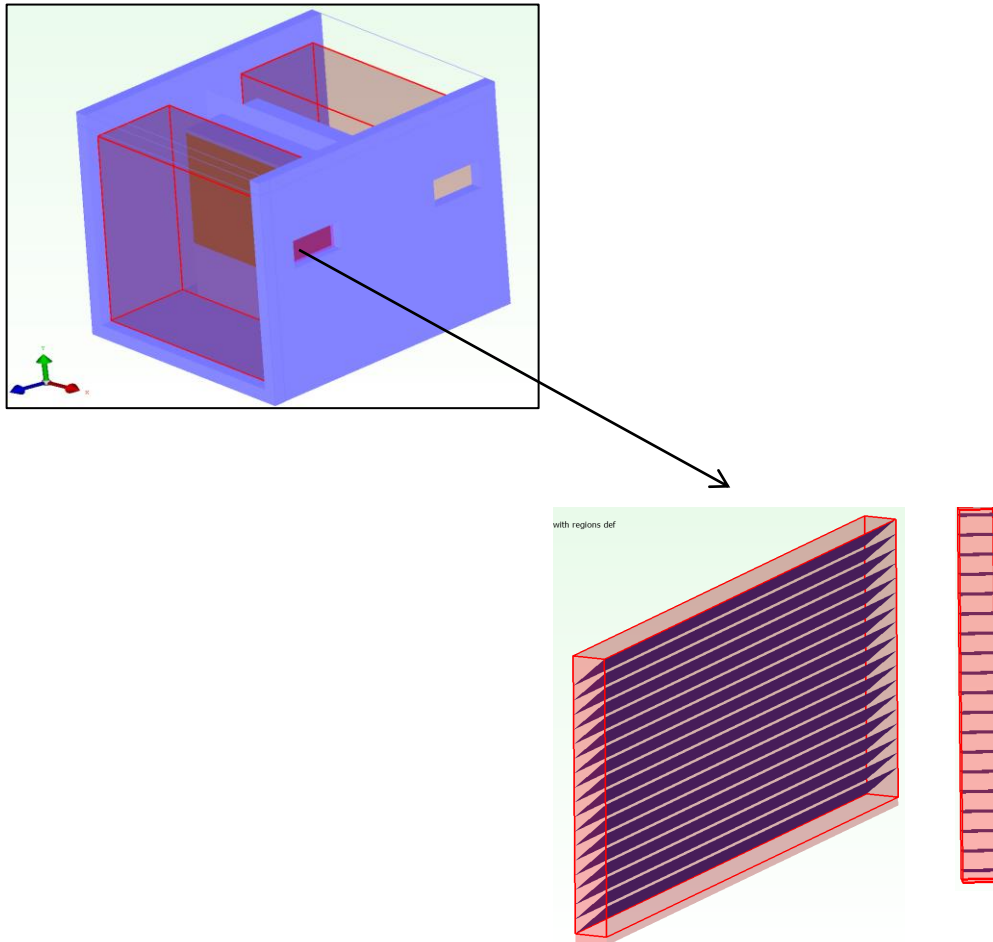

Figure 41 Inlet Louver at 0 degree orientation

6.1.1 Thermal contour in IT pod

The thermal profile at the exhaust of the server has been plotted for this case. We observe that temperature is slightly increased in second and third cabinet when compared to other two cabinets.

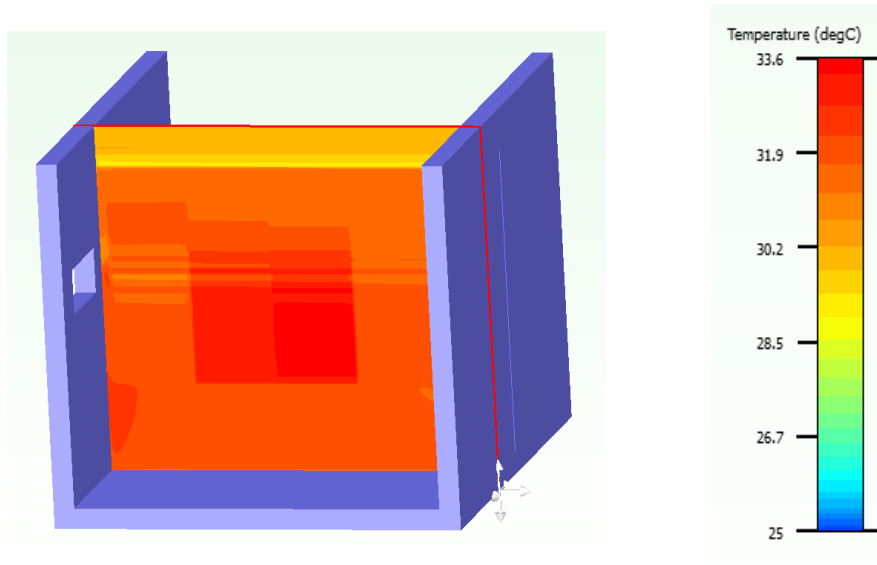
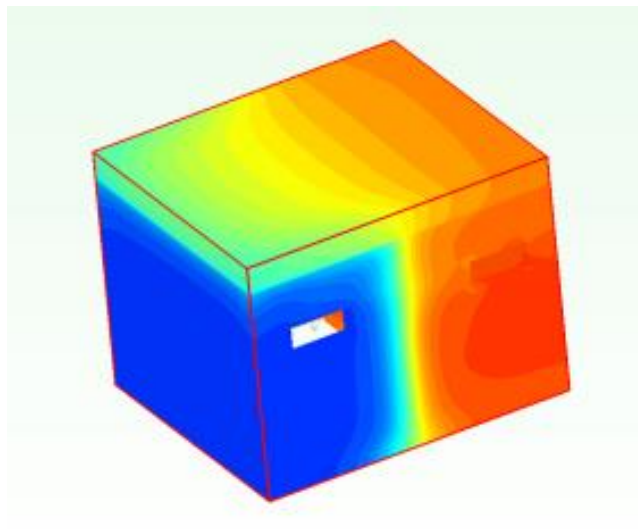

Figure 42 Thermal contour for 0 degree



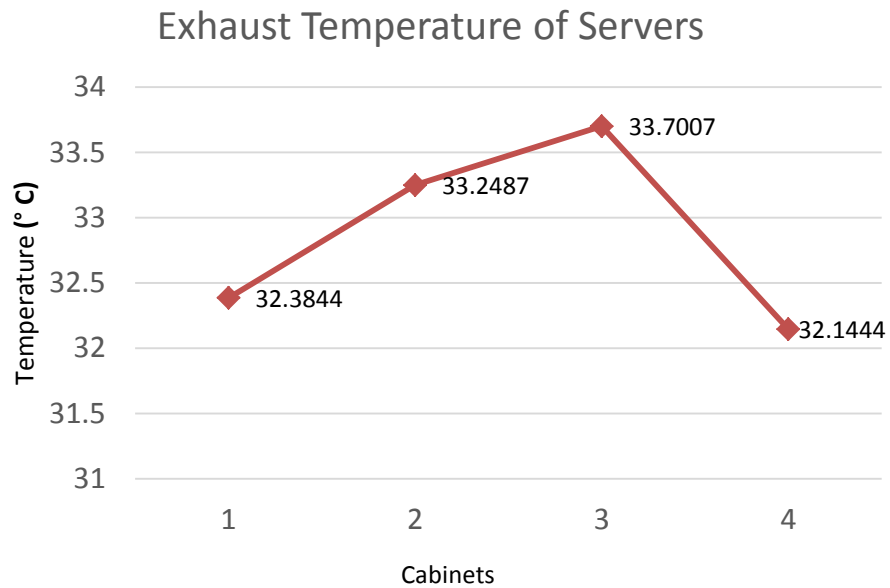

Figure 43 Temperature distribution across the racks

It can be observed from the above graph that the temperature across the server exhaust for third cabinet is more than the rest of the cabinets. This is due to the air moving at the faster rate and recirculating after hitting the wall. This forms a low pressure region near the third cabinet making the server fan difficult to draw air and cool the IT equipment.

6.1.2 Air flow Distribution in the IT pod

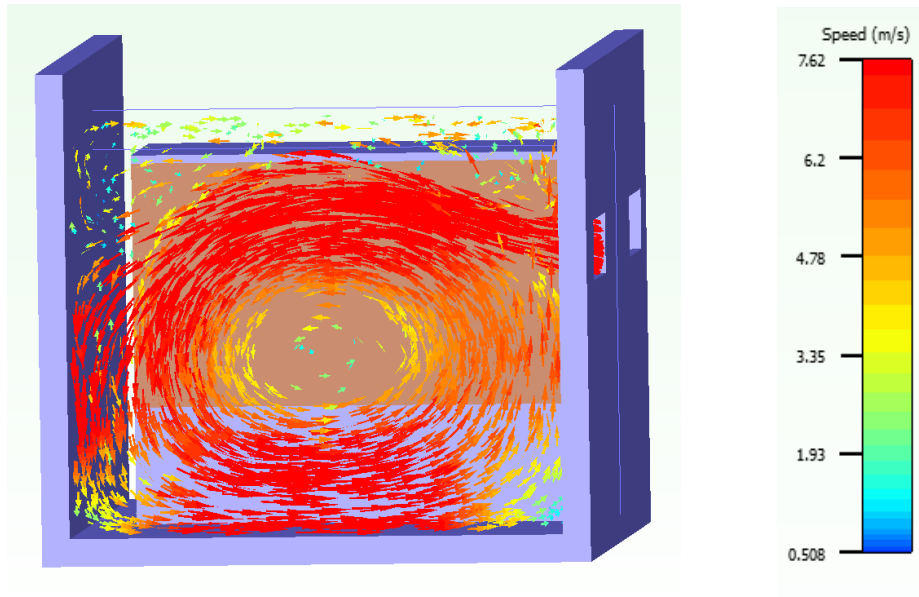

Figure 44 Particle trace of air flow for 0 degree case

From the above figure it can be observed that high speed air is diffused into the cold aisle and recirculated at the center of third cabinet region. Hence a low pressure region is formed in front of third cabinet making the server fans present in third cabinet difficult to draw air. Hence the temperature in third cabinet region is high when compared to other cabinet racks.

6.2 Case study 15 degree angle

The second case, Inlet louver blades are oriented at 15 ° to horizontal. The free area ratio has been reduced when compared to first case.

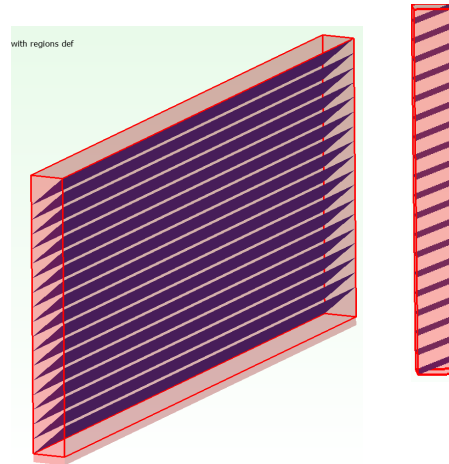

Figure 45 Inlet louvers at 15 degree case

6.2.1 Thermal Contour in IT pod

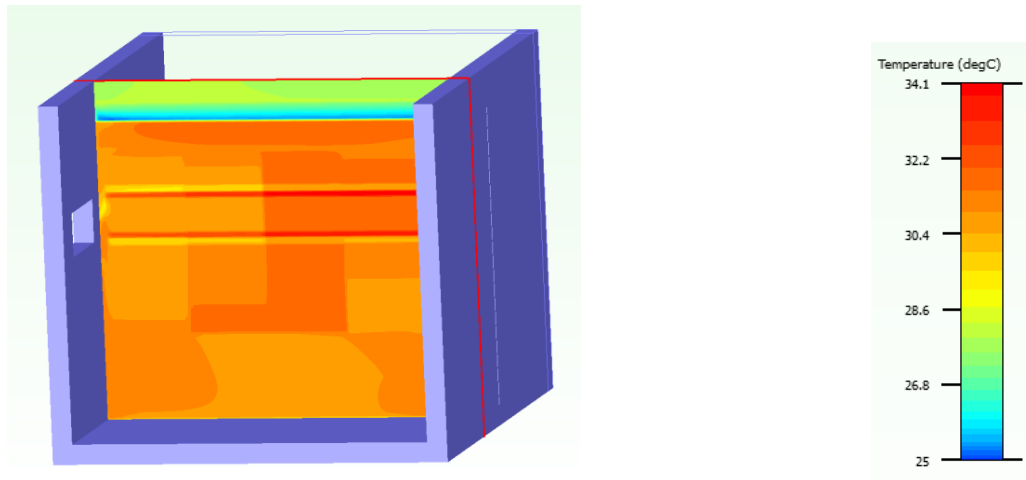

Figure 46 Thermal contour for 15 degree case

Exhaust Temperature of Servers

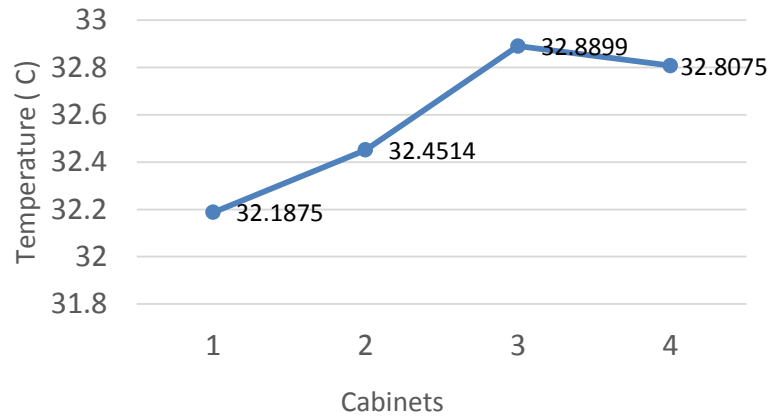

Figure 47 Temperature distribution across server racks

We observe that the temperature is uniform with a slight variation at the maximum temperature is observed at the third cabinet racks. This is due to more air recirculating near the third cabinet region.

6.2.2 Air flow Distribution inside IT pod

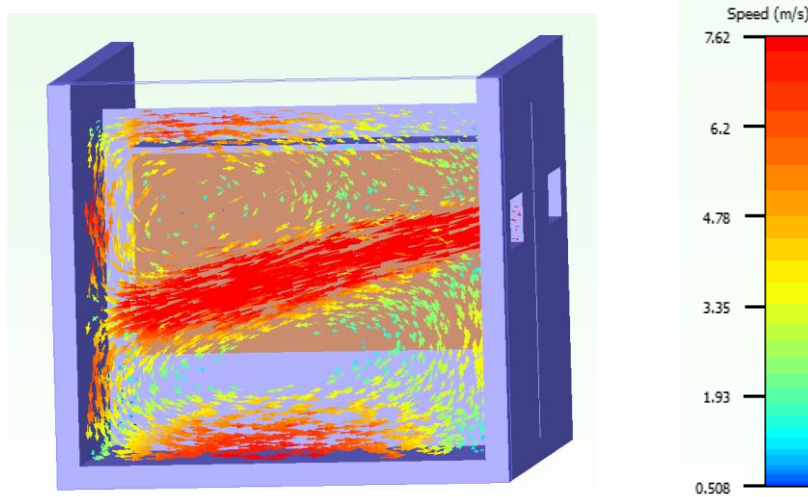

Figure 48 Air flow pattern for 15 degree case

From figure above, we can observe the air flow pattern is smooth with less recirculations at the center and low pressure region is not that effective when compared to zero degree case. Hence the flow rate is adequate through the servers in the cabinet racks.

6.3 Case study 25 degree angle:

The third case, Inlet louver blades are oriented at 25 ° to horizontal. The free area ratio has been further reduced when compared to first two cases.

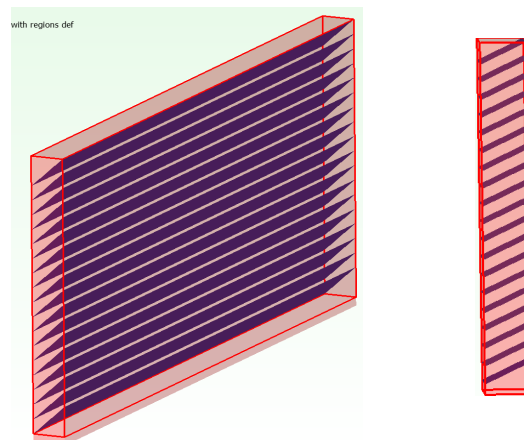

Figure 49 Inlet louvers at 25 degrees

6.3.1 Thermal Contour in the IT Pod

The thermal profile at the exhaust of the server has been plotted for this case. We observe that temperature is uniform and slightly increased in third cabinet when compared to other two cabinets.

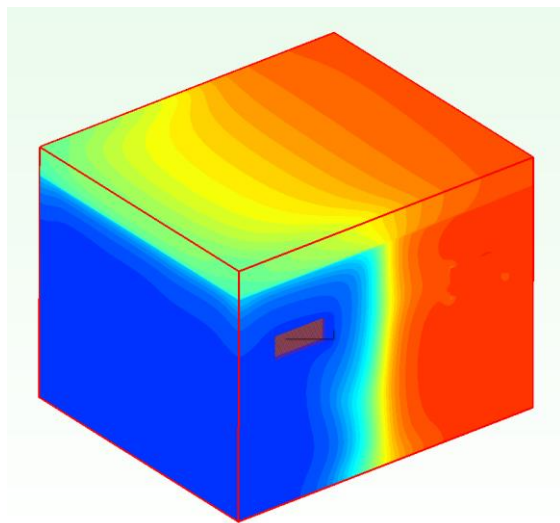
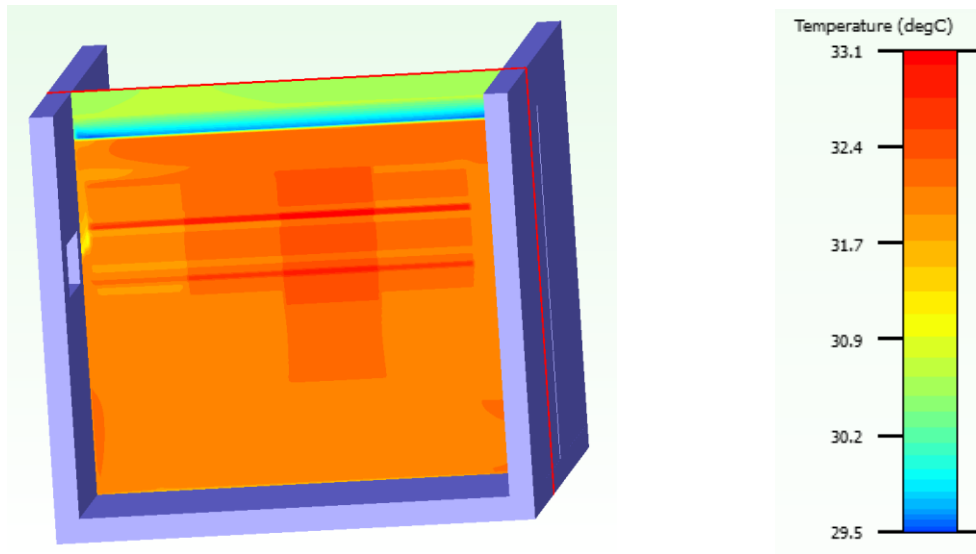

Figure 50 Thermal profile of IT pod for 25 degree case

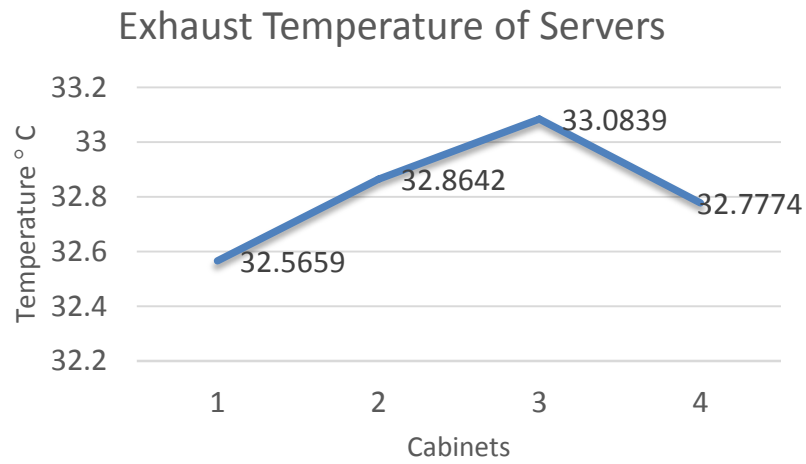

Figure 51 Temperature distribution across server racks

It can be seen from the above graph that uniform cooling is observed in the IT pod for this Louver orientation.

6.3.2 Air flow Distribution inside IT pod

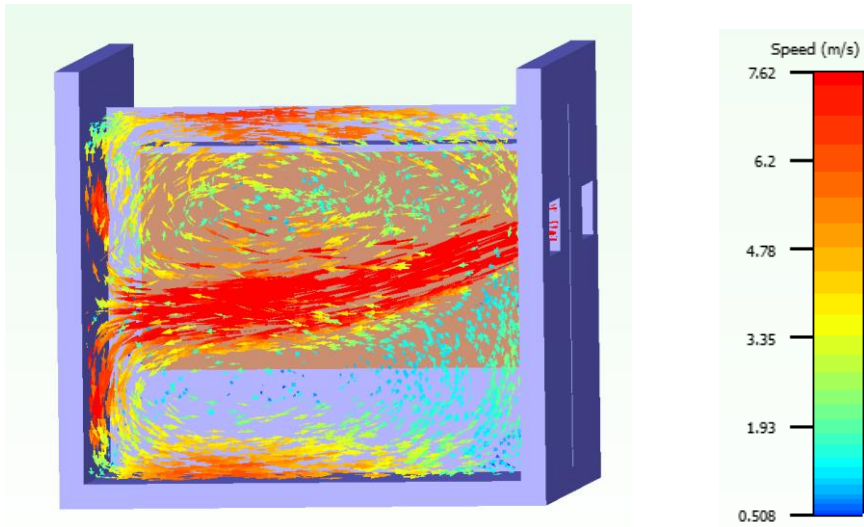

Figure 52 Air flow pattern for 25 degree case

It can be seen from the above graph that uniform cooling is observed because the air recirculations is less when compared to first two cases. The server draws in adequate air to required cool them.

6.4 Case study 35 degree angle

The third case, Inlet louver blades are oriented at 25 ° to horizontal. The free area ratio has been further reduced when compared to first two cases.

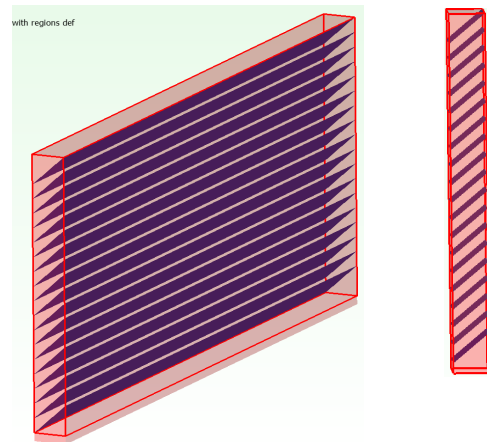

Figure 53 Inlet louvers at 35 degrees

6.4.1 Thermal Contour in the IT Pod

The thermal profile at the exhaust of the server has been plotted. We observe that temperature is greater in third cabinet when compared to other cabinets.

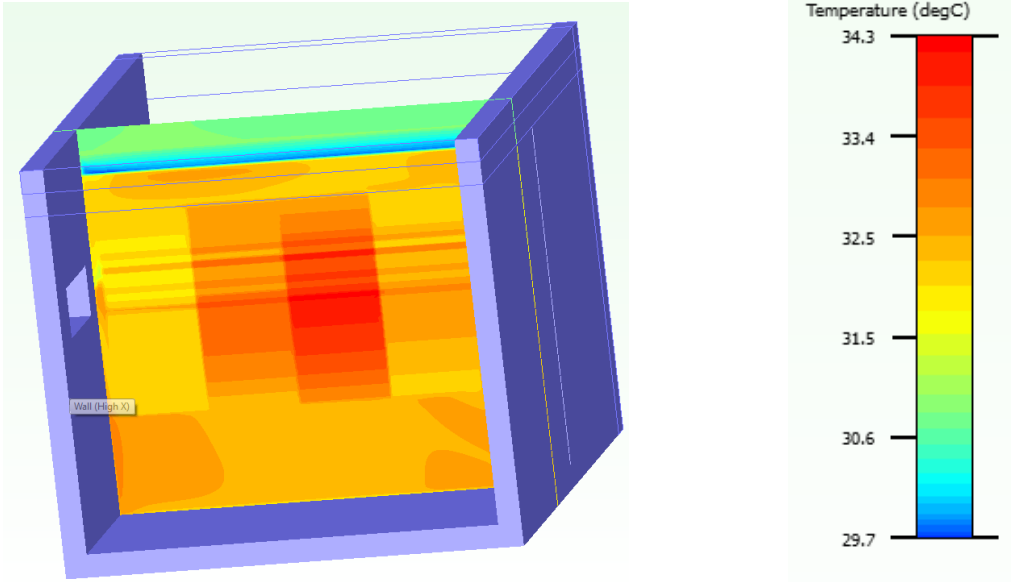

Figure 54 Thermal profile of IT pod for 35 degree case

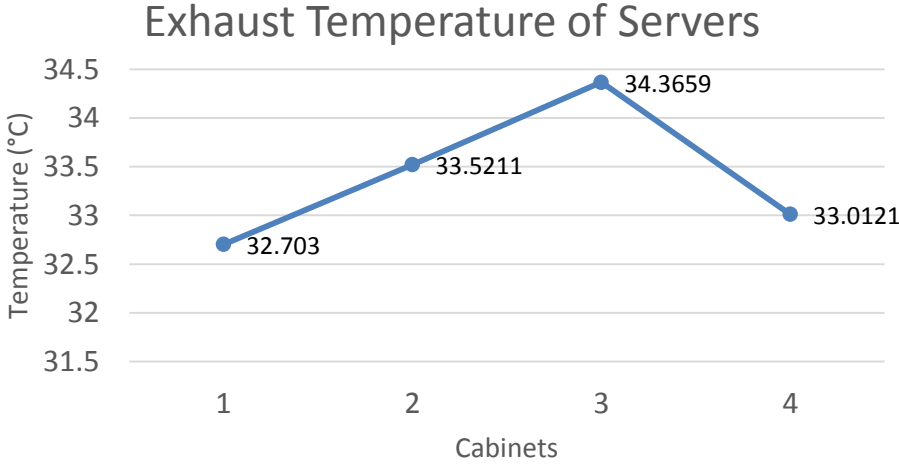

Figure 55 Temperature distribution across server racks

6.4.2 Air flow Distribution inside IT pod

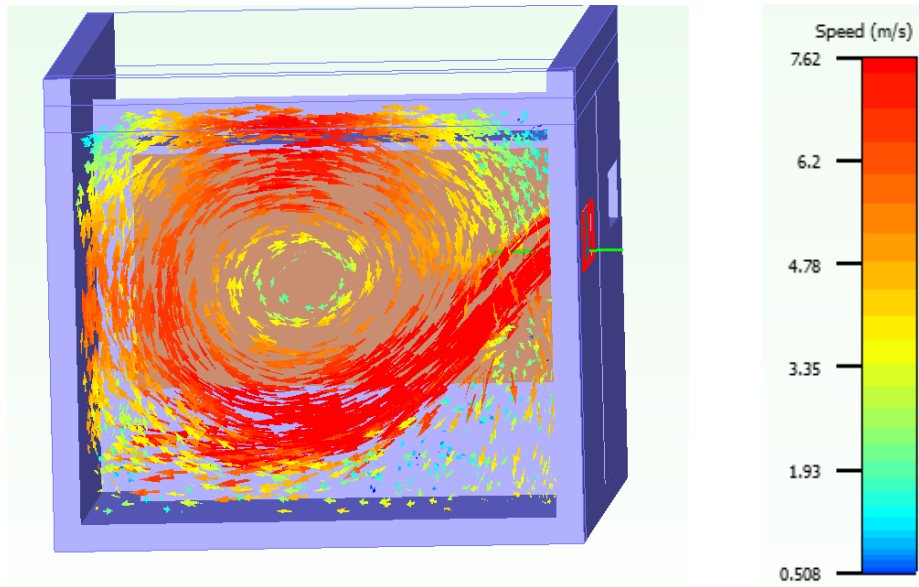

Figure 56 Air flow pattern for 35 degree case

6.5 Case study 45 degree angle

The fifth case, Inlet louver blades are oriented at 45° to horizontal. The free area ratio is very less when compared to all the above cases.

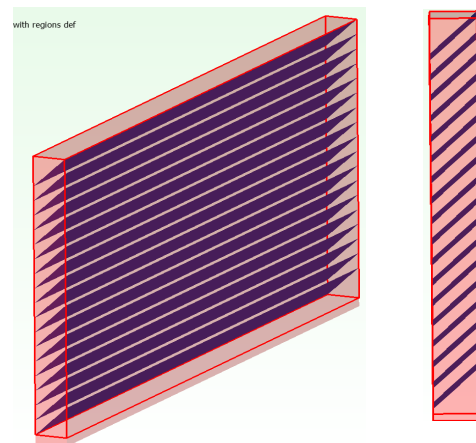

Figure 57 Inlet louvers at 45 degrees

6.5.1 Thermal Contour in the IT Pod

The thermal profile at the exhaust of the server has been plotted. We observe that temperature is greater in first cabinet when compared to other cabinets. This is due to more recirculation near the first cabinet region.

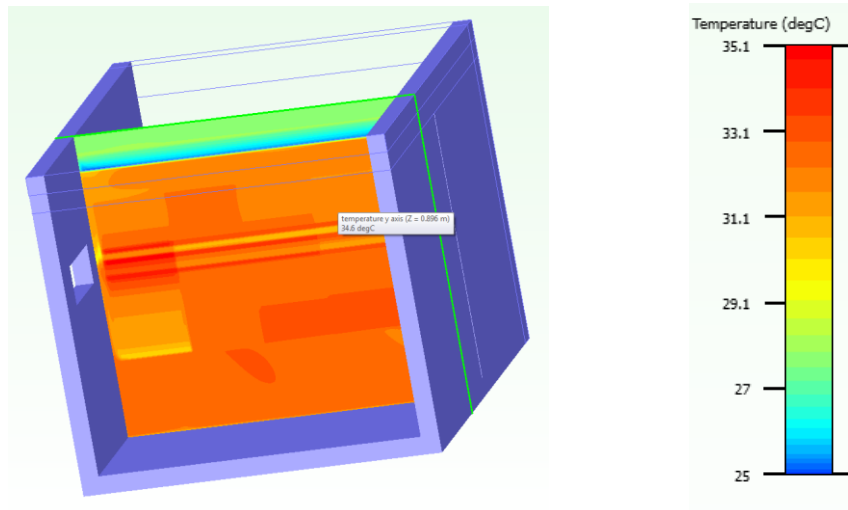
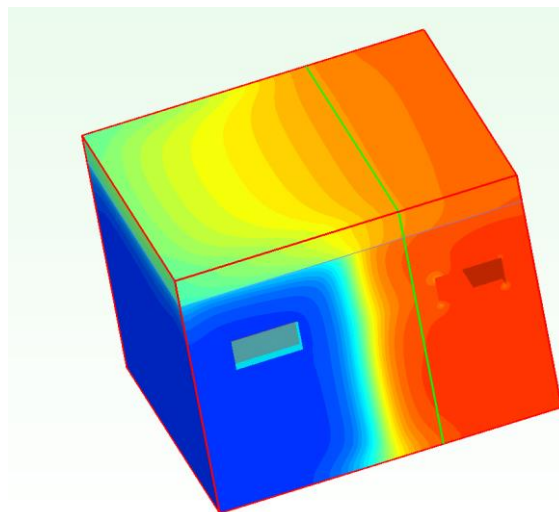

Figure 58 Thermal profile of IT pod for 35 degree case



6.5.2 Air flow Distribution inside IT pod

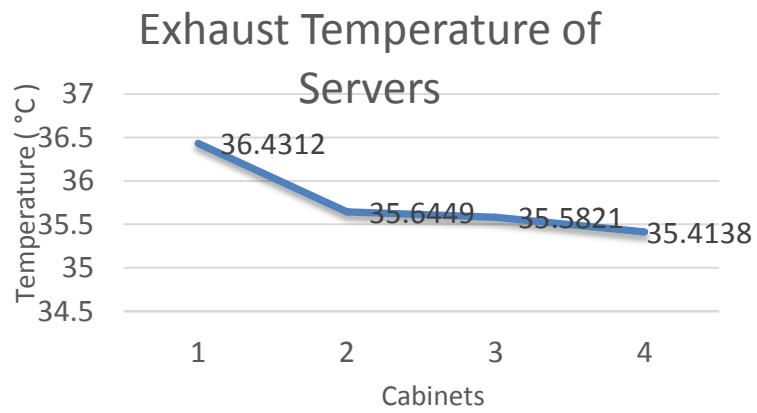

Figure 59 Temperature distribution across server racks

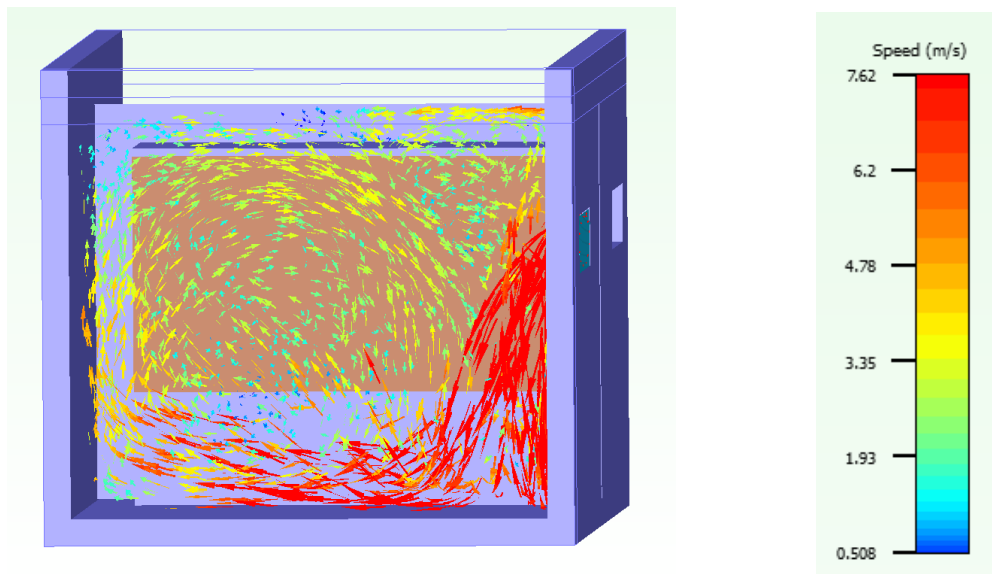

Figure 60 Air flow pattern for 45 degree case

It is observed from the particle trace above, that more air recirculations are present in this orientation when compared to all the other orientations discussed above. This causes less flow rate passing through the server racks.

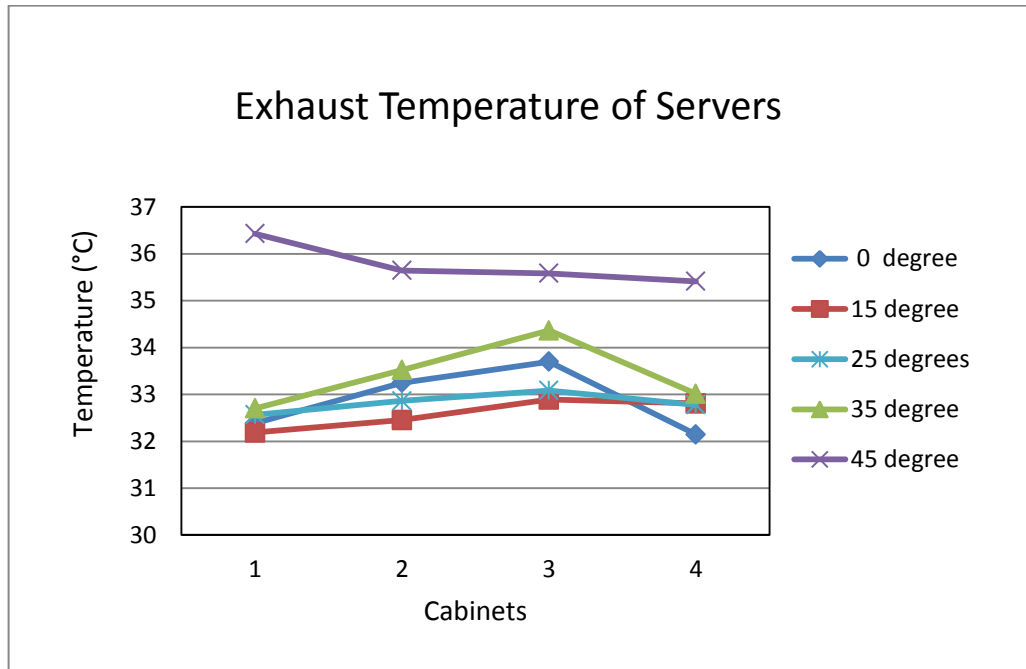

Figure 61 Temperature distribution across server racks for different louver orientation

It can be observed in the graph above that for 45 degree orientation the maximum temperature is obtained in the first cabinet. This is because the louver present in this orientation directs air to face the ground directly and pass through the cold aisle and allows very less amount of air to pass in the first cabinet. We can observe that for 25 degrees uniform cooling is achieved in the IT pod.

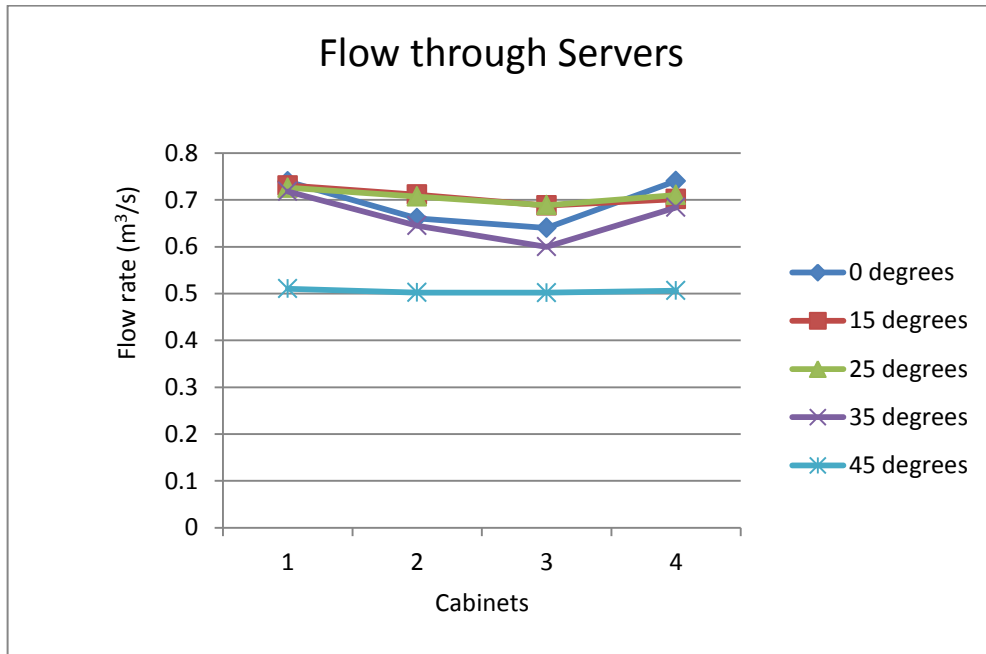

Figure 62 Flow rate through server racks for different orientations

From the graph above, it is clear that for 45 degrees the flow rate through the servers is less when compared to other orientations. This is due to the fact that it causes more air recirculation and form low pressure regions making the server fans difficult to draw air through it.

6.6 II set of blade spacing Results

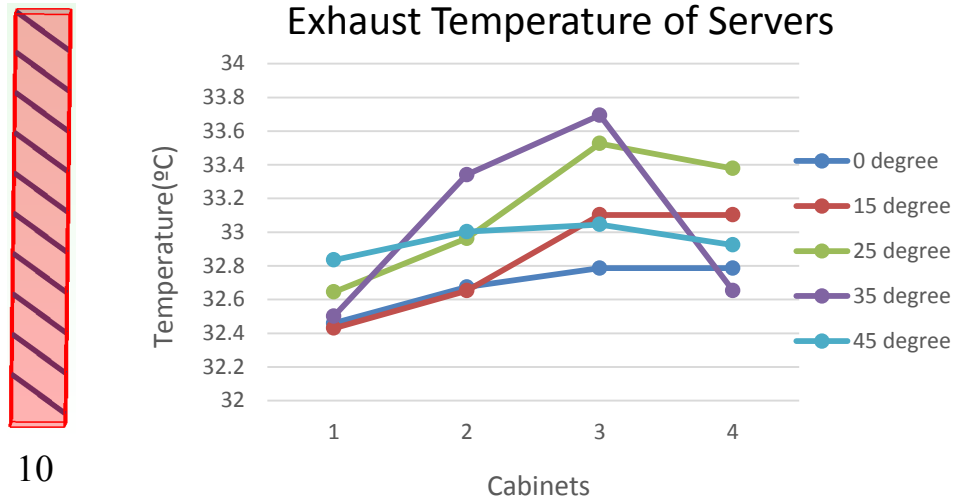

Figure 63 Temperature distribution across server racks for II set of blade spacing

- For the second case the ΔT max was low at 45 ° when compared with the first set of blade spacing.
- For 0° Louver orientation, the temperature at I cabinet is lower than that of 45 °
- This is due to more flow rate passing through the cabinet with 0 ° orientation.

6.6.1 Comparison between the I and II set of spacing

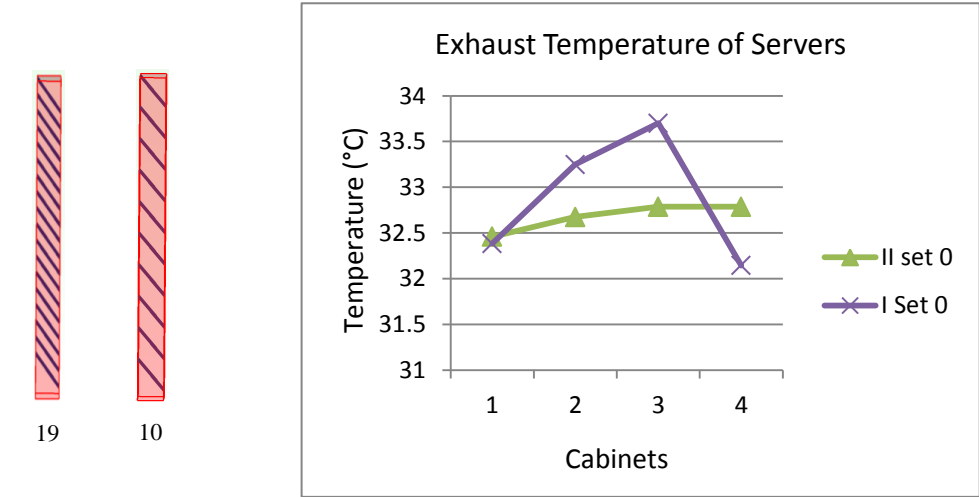

Figure 64 Comparison of Temperature distribution between I and II set for 0 degree

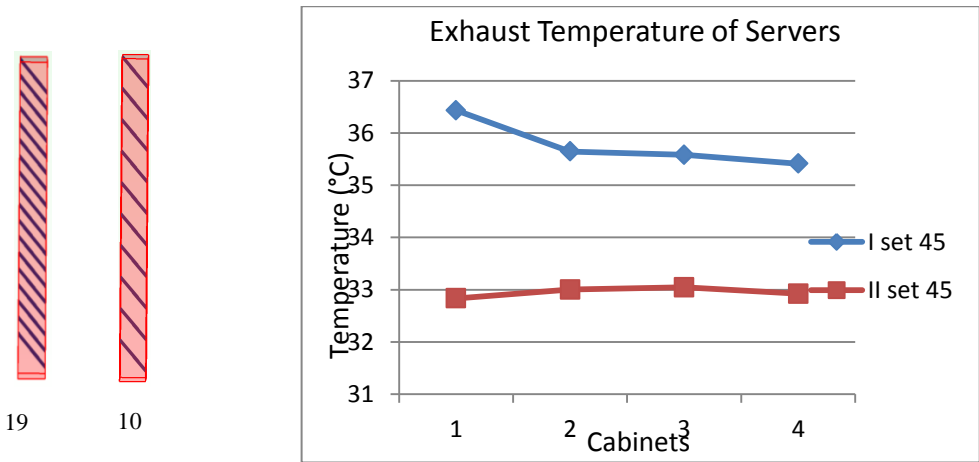

Figure 65 Comparison of Temperature distribution between I and II set for 45 degree

It is observed from the above two graphs that the temperature is lower in II set of blade spacing when compared to I set of spacing. This is due to increased free area ratio in second set of spacing.

6.7 Vertical louver arrangement

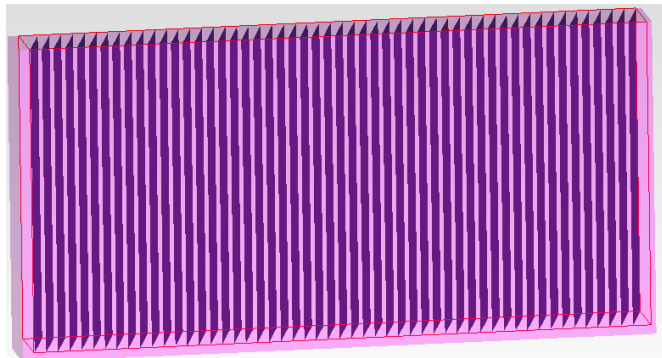

Figure 66 Vertical louver arrangement

In this case louver blades were vertically arranged and are oriented at 15 degrees facing towards the cabinets. From the comparison chart below, We observe below that in vertical louver arrangement lower temperature is achieved in first and fourth cabinets. Second and third cabinets are at almost equal temperature.

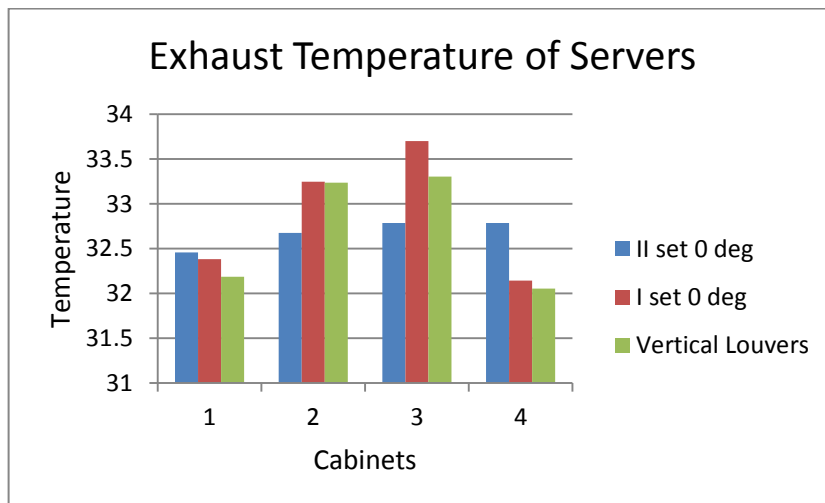

Figure 67 Comparison chart among I set II set and Vertical louver case

CHAPTER 7

RECOMMENDATIONS AND FUTURE WORK

7.1 Recommendations

Based on literature survey and calculations on free area ratio and water penetration the following conclusions can be drawn.

- The temperature inside the servers are relatively uniform for 15 ° and 25 ° for first case
- More air re circulations are observed for 45 ° causing the temperature rise inside the servers.
- The 25 ° Louver orientation in the first case should be considered as a better thermal management criteria because it has optimum free area ratio and can be used for inlet diffusers.
- Effect the blower fans in cooling unit : For 0 degrees, Flow rate entering the cold aisle 5713 cfm
- For 45 degrees the flow rate inside the IT pod is 4281.7 CFM. The flow rate has been reduced when the orientation was changed from 0 to 45 degrees.
- The second scenario was suited best for 45 ° degree orientation when compared with that of I scenario
- It can be concluded that for the same set of blade spacing as present at the research facility 25 ° louver orientation suits best.
- For the same set of louver orientation at 45 ° , second set of blade spacing suits best.
- The vertical louver arrangement helps to achieve uniform cooling in first and fourth cabinets.
- The appropriate louver design should be selected while keeping the water penetration also in consideration

7.2 Future Work

- Future work can be done on showing the effect of louver orientation on the pressure inside the servers.
- Different Louver shapes can also be modeled and simulated to visualize the thermal performance in the IT pod.
- Detailed study on the shape of Louvers with water penetration effect can be carried out to enhance better thermal management in the IT Pod.
- Solar loading does play an important role and also can be included in the CFD model.

REFERENCES

1. <http://www.greendatacenternews.org/articles/749395/comatose-servers-and-data-center-metrics-are-killi>
2. <http://www.metropolitandoor.com/docs/wall-louvers/lv-drainable.html>
3. N. Shah, "CFD Analysis of Direct Evaporative Cooling Zone of Air-side Economizer for Containerized Data Center," May 2012.
4. Ron Bednar, Buster Long, Suzen Shaw., "Deploying and using Containerized/Modular Data Center Facilities", 2011.
5. <http://www.wescorhvac.com/Evaporative%20cooling%20white%20paper.htm>
6. Architectural Louvers
http://www.archlouvers.com/How_Louvers_Work.htm
7. Energy Star, "Air-Side Economizer."
https://www.energystar.gov/products/low_carbon_it_campaign/12_ways_save_energy_data_center/air_side_economizer
8. <http://www.baltimoreaircoil.com/english/what-is-evaporative-cooling>
9. <http://www.drenergysaver.com/cooling-systems/evaporative-cooling/direct-evaporative-cooling.html>
10. https://en.wikipedia.org/wiki/Air_handler
11. <http://www.thomaseng.com/air-handling-systems/>
12. <http://www.brentwoodindustries.com/products/cooling-tower/accessories/inlet-louvers.php>
13. <https://www.yahoo.com/news/bp/how-a-stock-r8-compares-to-audi-s-race-winning-r8-lms-ultra-race-car-190726944.html>
14. Industrial Louvers Inc, "Specializing in the fabrication of louvers and a Whole Lot more for the Architectural and Mechanical Markets", 2010.

15. K.Aurangabadkar , “Impact Of Louver Orientation On Air Flow Distribution And Thermal Management Of Data Centers”, March 2013
16. <http://www.rlcraigco.com/pdf/louvers-selection-design-considerations-and-details>
17. S.Sathyanarayan, ”Experimental and computational analysis of an IT pod and its cooling system” May 2014.

BIOGRAPHICAL INFORMATION

Avinash Kumar Ray was born in Vijayawada, India. He received his Bachelor's Degree in Mechanical Engineering from Amrita University, Coimbatore, India in May 2014. He completed his Master of Science degree in Mechanical Engineering at the University of Texas at Arlington in May 2016.

His primary research includes cooling of Modular data center where he has worked on steady state and transient state analysis. Avinash has been involved a number of projects in UTA with the industry especially with room level cooling of a data center.

He has extensively modeled the IT pod of modular data center with detailed servers stacked inside each cabinet and performed a steady state analysis CFD model and studied the effect of louver blade orientation on cooling of data center equipment to reduce the air recirculation effect due to the orientation of louver blades. He has joined the EMNSPC team in March 2015 and worked in various Industries funded projects since then.