

COMPARISON OF STEEL AND COMPOSITE LEAF SPRINGS USING FEA

by

PRASHIK SUNIL GAIKWAD

Presented to the Faculty of the Graduate School of
The University of Texas at Arlington in Partial Fulfillment
of the Requirements
for the Degree of

MASTER OF SCIENCE IN MECHANICAL ENGINEERING

THE UNIVERSITY OF TEXAS AT ARLINGTON

Spring 2018

Copyright © by PRASHIK SUNIL GAIKWAD 2018

All Rights Reserved



Acknowledgements

I would like to express my gratitude to Dr. Andrey Beyle for his inspiring guidance, encouragement and for investing his valuable time in mentoring me. It has been a journey filled with learning experience. I thank Dr. Andrey Beyle for being on the thesis defense committee chair.

I would also like to extend my sincere thanks and appreciation to Dr. Kenneth Reifsnider and Dr. Kent Lawrence for serving on the thesis defense committee and providing me with several learning opportunities.

I am grateful to my parents, friends and all those who helped and supported me to achieve my goal.

April 16, 2018

Abstract

COMPARISON OF STEEL AND COMPOSITE LEAF SPRING USING FEA

PRASHIK SUNIL GAIKWAD, MS MECHANICAL ENGINEERING

The University of Texas at Arlington, 2018

Supervising Professor: ANDREY BEYLE

Composite materials are widely used in aeronautical, marine and automotive industries, because of their excellent mechanical properties, low density and ease of manufacture. Due to this increasing trend to utilize composite materials, it has become necessary to investigate the pros and cons of composites. Increasing competition and innovation in automobile sector tends to modify the existing products by new and advanced material products. A suspension system of vehicle is also an area where these innovations are carried out regularly. Leaf springs are one of the oldest suspension components that are being still used widely in automobiles. They contribute to 15-20% unsprung weight. Weight reduction is one of the utmost priority of all by automobile manufacturers. The automobile industry has shown increased interest in the use of composite leaf spring in the place of conventional steel leaf spring due to its high strength to weight ratio. This work deals with replacement of conventional steel leaf spring with composite leaf spring. Comparison of steel and composite leaf spring using ANSYS V17.2 software. Then the effect of change in design on stress, deformation, strain energy, fatigue life was studied using ANSYS V17.2. Anisotropic material properties are taken into account to observe resultant behavior. The leaf spring is modeled using SOLIDWORKS 2017 for the four materials, E glass epoxy, S glass Epoxy, Kevlar epoxy and Carbon epoxy.

Table of Contents

Acknowledgements	iii
Abstract	iv
List of Illustrations	vii
List of Tables	ix
Chapter 1 Introduction	1
1.1. Leaf springs.....	2
1.2. Composites.....	4
1.3 Objective.....	12
Chapter 2 Evolution of eye end design	13
Chapter 3 Calculations and CAD geometry.....	18
3.1. Calculation of Leaf spring	18
3.2. Load calculation of leaf spring	19
3.3 Cad geometry and dimensions	20
3.4. Boundary conditions	22
3.5. Meshed model.....	22
Chapter 4 Materials.....	25
Chapter 5 Results	28
5.1. Results of 65Si7 stress and deformation.....	28
5.2. Results of composites stress and deformation.....	30
5.3. Design change.....	31
5.4. Comparison of stress and deformation for design change	32
5.5. Stress analysis in each ply	34
5.6. Factor of Safety.....	36
5.7. Natural frequency	37

5.8. Design rubber.....	38
5.9. Strain energy	38
5.10. Fatigue life analysis.....	39
Future Work	44
Conclusions.....	45
References.....	46
Biographical Information.....	48

List of Illustrations

Fig 1.1 Laminate composites	6
Fig 1.2 Unbonded views of anti-symmetric and symmetric cross-ply laminates.....	7
Fig 1.3 Representation of an angle lamina with the local and principal directions.....	8
Fig 1.4 Orientation of the fibers of a unidirectional composite along x1 direction.....	9
Fig 2.1 Different types of eye design.....	14
Fig 2.2 Eye end of the design	14
Fig 2.3 Delamination at interface.....	15
Fig 2.4 Transverse wrapping	16
Fig 2.5 Delamination of wrapping fibers	16
Fig 2.6 Design of open eye end.....	17
Fig 3.1 Leaf spring	18
Fig 3.2 CAD model of leaf spring.....	20
Fig 3.3 Dimensions of leaf spring.....	21
Fig 3.4 Boundary Condition of leaf spring	22
Fig 3.5 Meshed model.	23
Fig 3.6 SOLID 186	24
Fig 5.1 Results of static analysis of 65Si7.....	29

Fig 5.2 Stress comparison for design change	32
Fig 5.3 Deformation comparison for design change	33
Fig 5.4 Stress comparison of different design of E glass epoxy leaf spring	33
Fig 5.5 Stresses in each ply in E glass epoxy leaf spring	36
Fig 5.6 Comparison of factor of safety.....	37
Fig 5.7 Comparison of natural frequency	37
Fig 5.8 Result of fatigue life of 65Si7	41

List of Tables

Table 4.1 Material properties of 65Si7	25
Table 4.2 Material properties of E/S glass/Carbon fiber/Kevlar	27
Table 4.3 Material properties of E/S glass/Carbon fiber/Kevlar for $V_f = 60\%$	27
Table 5.1 Results of 65Si7	30
Table 5.2 Stress comparison of E/S glass/Carbon fiber/Kevlar	30
Table 5.3 Deformation comparison of 65Si7/E/S glass/Carbon fiber/Kevlar	31
Table 5.4 Comparison of strain energy	38

Chapter 1

Introduction

Suspension system is the term given to the system of springs, shock absorbers and linkages that connects vehicle to the wheel. The main purpose of the suspension system is to damp the vibrations due to road irregularities. It also has additional purpose as support weight, allow rapid cornering without extreme rolling. It plays a crucial role in car handling specially in rolling, braking. The higher the suspension is mounted, the higher the CG of the car shifts from the ground which in turn result into increase in tendency of rolling. The suspension system accounts to 15-20 % of unsprung weight of the vehicle. Unsprung weight is the weight that is not supported by the suspension which includes wheel axles, wheel bearings, wheel hubs, tires, and a portion of the weight of driveshafts, springs, shock absorbers, and suspension links. There are different types of suspension system, but in this research, leaf springs are being studied.

1.1 Leaf springs

The chassis of an automobile includes the tires and the wheels that let the automobile move on the surface by maintaining the right amount of friction to keep it on that surface. The frame also holds together the vehicle structure while supporting the engine and body loads. This chassis is mounted over a suspension system, which also works as a load support for the automobile. The most common type of suspension system available for commercial vehicles is the leaf spring suspension. Leaf springs are beams of high deflection that can be used individually as a single leaf, or in stacked assemblies of up to twenty leaves, as multi-leaf, depending on the type of the vehicle to be used on. Leaf springs function by absorbing the normal forces and vibration impacts due to road irregularities by means of the leaf deflection, stored in the form of strain energy for a short period, and then dissipated.

Leaf spring was invented by an Englishman named 'Obadiah Elliot' in the year 1725. He used this leaf spring for his carriage. He simply piled one steel leaf over another, pinned them together and shackled them to the frame of the carriage. First composite leaf spring was manufactured and used by General Motors. They used this composite leaf spring in 'CORVETTE CAR'. They have installed the leaf spring in the transverse direction instead in longitudinal axis. This gave them advantage in lowering the CG of the car and resulting into more stability of the car.

Advantages of Leaf spring

- The way the suspension is constructed is really simple and strong, acting as a linkage that holds the axle in position without the need for separate linkage.
- Extra weight and costs are reduced because of the rear axle location. This eliminates the need for trailing arms
- Leaf springs support the weight of the chassis, making them ideal for commercial vehicles.
- They also control axle damping.
- If installed in the transverse direction, it is very useful in controlling rolling tendencies because of lowering of CG of the vehicle.

Disadvantages of Leaf Spring

- They aren't always the easiest to install – but there is a clear process to follow that makes life much easier.
- Over time, the springs tend to lose shape and can sag. When the sag is uneven, it can alter the cross weight of the vehicle which can affect the handling slightly. This can also change the axle-to-mount angle.

1.2. Composites [16]

Composites are a very large category of materials whose main characteristic is that they are the combination of two or more distinct constituents. The present research will concentrate on a category of composites called Fiber-Reinforced Plastics (FRP). FRPs are synthetic composites of epoxy resin and fibrous high strength materials. FRPs are high in strength and low in stiffness and very low in weight, and are many times utilized as an alternative to metals in structures where high performance and low weight is a desirable combination. Another reason why composites are a very popular alternative to metals, regards applications requiring materials of high corrosion resistance [4].

This research will discuss unidirectional reinforced-plastics. The fibers in a FRP can exist in two major forms; as unidirectional reinforcement where the fibers are continuous along one direction of the composites, or bidirectional reinforcement, also referred to as woven, where the fibers are knit in a cloth form and fibers occupy two directions of the composite.

FRPs with glass fiber reinforcements, what is commonly known as fiberglass, are called Glass Fiber Reinforced Plastics (GFRPs) [5], and are the main material used in the production of composite leaf springs. Glass is a non-crystalline material with isotropic properties [6]. The most common glass fibers E-glass are named after abbreviating the word *Electrical* thus denoting the electrical conductivity properties of the fibers. The high strength S-glass fibers, used in the aerospace industry, also take their name from the abbreviation of the word *Strength*. There are also other types of glass fibers such as C-glass and R-glass, also having names describing their properties. S-glass fibers are divided in subcategories, one of which, S2-glass.

Apart from the fibrous constituent, composite materials also have a matrix constituent. In composites the matrix constituent may be any type of known material, however, polymeric matrices are the most commonly used in composites [8,7]. Polymer Matrix Composites (PMCs) may have a thermoplastic, thermoset or rubber matrix. However, thermosets are the most widely used as composite matrices in GFRPs due to the ease of manufacturing they can provide.

Apart from the low stress at a lower weight; composites provide a variety of ways to be formed. One of the advantages of composite materials is that there is no need to first create the composite and then the component to be manufactured, as both component and composite material are manufactured simultaneously.

The orientation of fiber reinforcement in FRPs can be chosen in the optimal combination for the structure to be manufactured, whether the reinforcement is unidirectional or woven. The fibers in a unidirectional composite are placed randomly in a matrix. The matrix and fiber volume fractions will determine the final properties of the composite, which may be expressed through the rule of mixtures [8].

A composite material may have a laminar form, meaning that it is composed of a definite number of layers, also referred to as laminae or plies, each of which have a matrix

fiber constituent. The fiber orientation may vary among the laminae, as may vary the fiber and matrix fractions and materials. All laminae together compose the laminate or ply stack (Fig 1.1), the composite material having a certain ply sequence defined by the different fiber orientations in the plies. The ply, or stacking, sequence, volume fractions of the constituents, and number of laminae in the laminate determine the ultimate properties of the composite structure. The number of plies can be even or odd (Fig 1.2), and will result in an anti-symmetric or symmetric laminates, which will also affect the performance and properties of the composite structure [4,9].

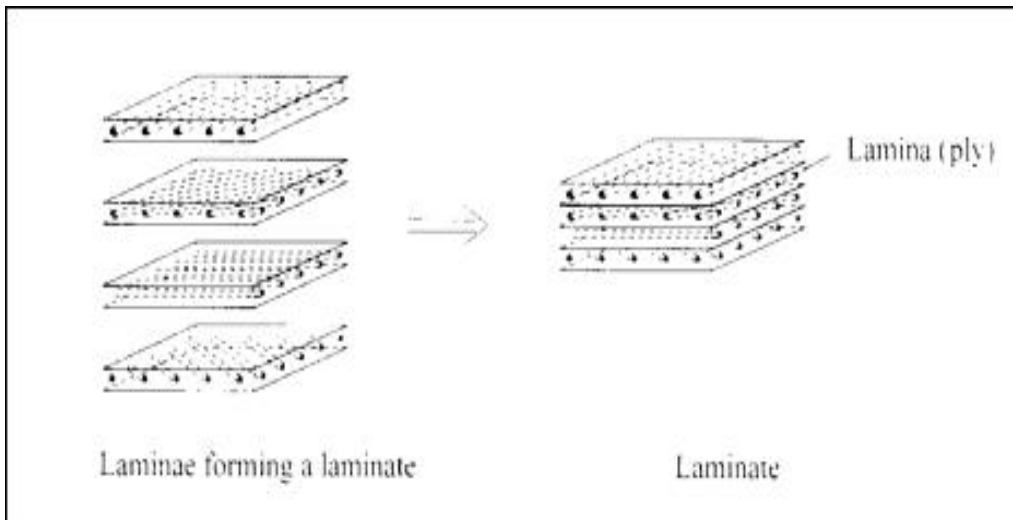

Fig 1.1 Laminate composites [10]

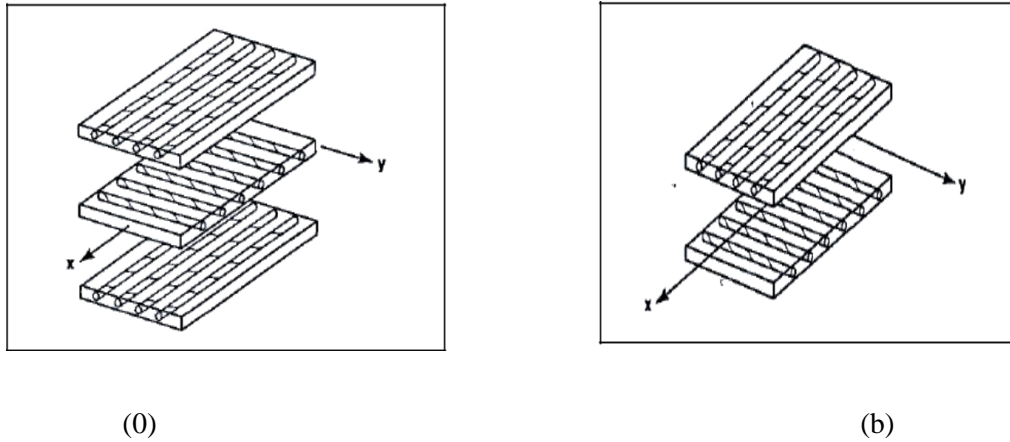

Fig 1.2 Unbonded views of anti-symmetric (a) and symmetric (b) cross-ply laminates

A composite material may have a laminar form, meaning that it is composed of a definite number of layers, also referred to as laminae or plies, each of which have a matrix and fiber constituent. The fiber orientation may vary among the laminae, as may vary the fiber and matrix fractions and materials. All laminae together compose the laminate or ply stack (Fig. 1.1), the composite material having a certain ply sequence defined by the different fiber orientations in the plies. The ply, or stacking, sequence, volume fractions of the constituents, and number of laminae in the laminate determine the ultimate properties of the composite structure. To proceed with any type of analysis of a lamina it is important to define a coordinate system. The Cartesian coordinates are typically used. It is possible that the fibers of a unidirectional lamina do not have the same orientation as the axis of a Cartesian coordinate system, but instead they make an angle with one of the axis (Fig. 1.3). Such a lamina is called angle or off-axis lamina, and a set of principal axis should be defined where direction 1 will be along the direction of the fibers, and direction 2 transverse to the fibers. A lamina whose fibers are oriented along the x or y-axis is called an on-axis lamina.

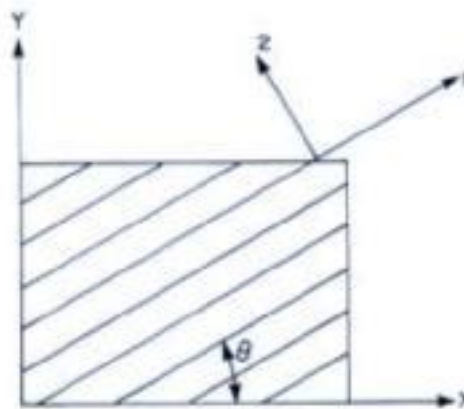

Fig 1.3 Representation of an angle lamina with the local and principal directions [11]

When an angle lamina is loaded longitudinal, or transversely, along the x or y directions, the loading is called off-axis. When the load direction coincides with the fibers' orientation the loading is termed on-axis loading [11].

Due to the very different mechanical properties of a GFRP's constituents, composite materials do not have an isotropic nature. The anisotropy of a laminate may be different for each layer, and therefore it is important to develop an analysis for the individual laminae, before considering the laminate as a whole. Composites also tend to be orthotropic or transversely isotropic.

A unidirectional composite is one that has all its reinforcing fibers positioned along one of its three directions (Fig. 4). Contrary to an isotropic material, such as a metal, the stiffness and strength of a composite varies depending on the direction of the material along which the properties are measured. When the composite in consideration is unidirectional, isotropic behavior can be assured in a cross-section of the material taken perpendicular to the fibers. A transversely isotropic material, as shown in Fig. 4, has identical properties along 2 and 3 directions. Transversely isotropic materials, therefore, have two sets of mechanical properties, along the transverse and longitudinal to the fibers directions, respectively [6].

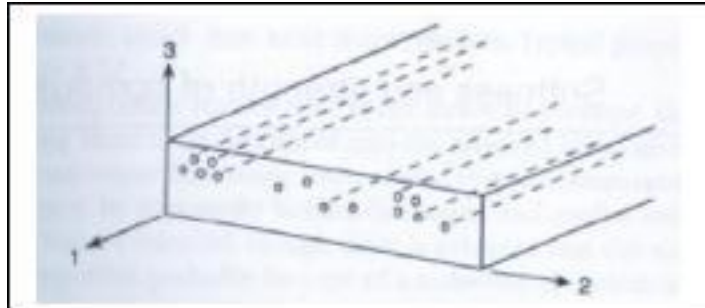

Fig 1.4 Orientation of the fibers of a unidirectional composite along x_1 direction

Apart from low stress and stiffness, composite materials fail differently than metals. Although, like metals composites are considered to have failed when they stop performing according to their design criteria [7], contrary to the case of homogeneous

isotropic materials such as metals where fatigue failure is characterized by the initiation and propagation of a crack, fatigue failure in composites is the result of accumulated damage [6,12]. Although in metals the strength of materials changes little or not at all during fatigue cycling [13], and it is the crack propagation that defines fatigue damage but in composites the strength of the material starts decreasing slowly early in the fatigue life, and towards the end of it, close to failure, the rate of decreasing strength becomes very rapid [14].

The effect of the intensity of the stress applied also differs among metals and composites. While low stresses are critical in the design of a metal structure, it is higher stresses, defining low cycle fatigue, with which caution should be taken when designing a composite structure [15].

Due to the different constituents that combine to make composite materials, failure of the composite may be due to different mechanisms called the failure modes of the composite. In composites failure begins in a micro-mechanic level, the level at which the mechanical behavior of the constituents is examined [8,9,10], and may be demonstrated as fiber, matrix or interface dominated failure, which includes delamination and de-bonding. Matrix and fiber failures are the cracking and fracture of the matrix or fiber constituents, respectively. Interface dominated failure, is the failure that is demonstrated at the interface of composites constituents. De-bonding is a microstructure interface-dominated failure mode, which involves the separation of the fibers from the matrix constituent. Delamination is also an interface-dominated failure during which adjacent laminae of the composite separate from each other, and is mainly initiated by inter-laminar tension and shear caused by the existence of free edge effects, structural discontinuities, variations in temperature

temperature and moisture, as well as localized defects induced in the material during manufacturing (e.g. drilling) [7,16]. Among these failure modes, delamination is maybe the most usual failure mode in laminated composites, especially components that undergo cyclic loading as composite leaf springs.

As micromechanical failure becomes macro mechanical, the result is catastrophic failure.

Depending on the loading that caused failure in the structure, failure modes can be characterized as tensile, compressive or shear.

1.3 Objective

The objective of this study and compare conventional steel leaf spring and composite leaf spring for weight, stress, stiffness, factor of safety and using four different materials for composites and then studying the effect of change of design of leaf spring. Comparing the conventional design and the new design for stress, stiffness, strain energy, fatigue life. In addition to this the effect of inserting rubber between the leaves on the stress, strain energy. Furthermore, improved models and materials are taken into consideration and the same boundary conditions are applied to check for their performance.

Chapter 2

Evolution of eye end design

Introduction [1]

The application of composite materials is limited due to the design of shackle that connects the leaf spring to the body/frame of the car [1]. Fig. 3.1 shows different types of the eye-end joint summarized by Shokrieh and Rezaei. Type (a) consists of a steel eye that can be bolted or pinned to the glass reinforced plastic (GRP) body of the spring [1]. Although bolted or riveted eye ends are fairly simple to manufacture for prototypes, they are not normally recommended for volume production. That is because fasteners are relatively expensive to produce and assemble [1]. Stress concentrations introduced by drilling are another concern for this type of joint. In joint type (b) the eye end and spring are manufactured simultaneously from the same material [1]. There is no stress concentration in this type. Reinforcement of composites at the junction of the eye and spring is necessary to avoid the delamination of unidirectional fibers [1]. This joint configuration has the disadvantages of high cost and manufacturing complexity.

Joint types I and (d) have a conical or concave width profile so that steel eye fittings with the same conical or concave profile can be mounted easily and reliably together with rubber pads. In these joints there is no stress concentration due to drilling, but the cost of manufacture of the conical or concave parts of the spring has to be considered. The original eye end of the double leaf considered in this work was molded simultaneously with the composite spring itself, as shown in Fig. 3.2. This design reduces the complexity and cost of the composite leaf spring. One problem with this design is the delamination which occurs at the overlap of layers coming back from the eye end which may initiate extensive delamination in the top leaf. The aim of this investigation is to improve the eye-end design to overcome the problem of the delamination failure.

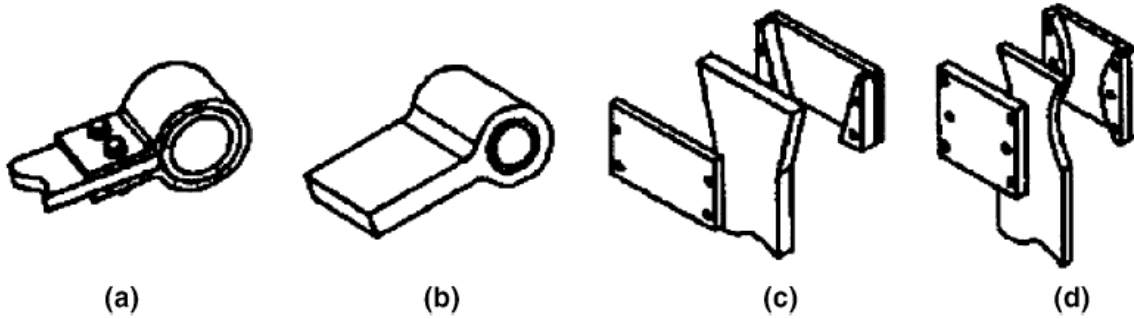

Different designs of joint for attaching the leaf spring to the vehicle body—from Shokrieh and Rezaei

Fig 2.1 Different types of eye design [1]

Current design and existing problem.

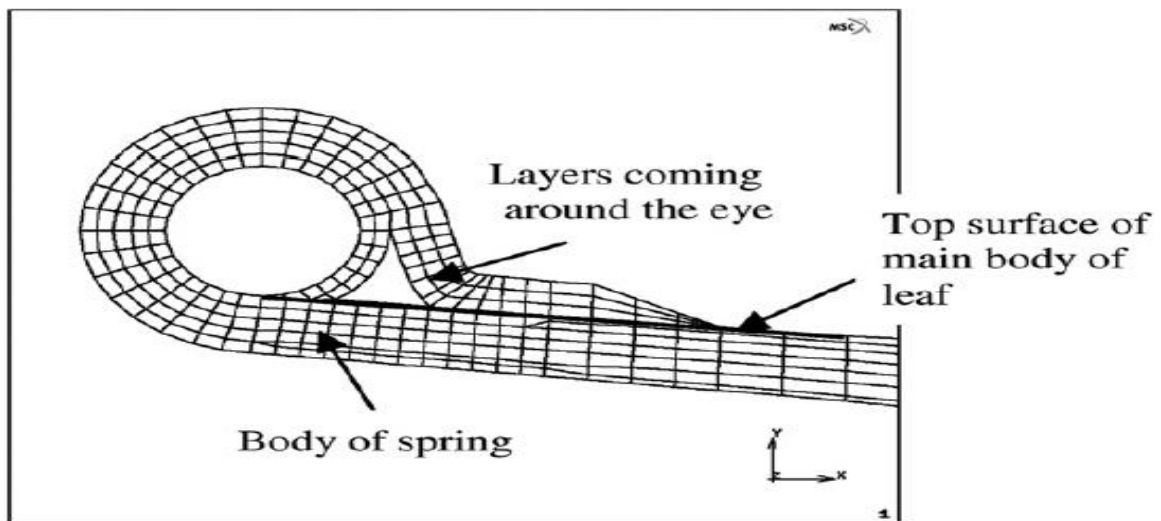

Fig. 2. Eye end of the first design.

Fig 2.2 Eye end of the design [1]

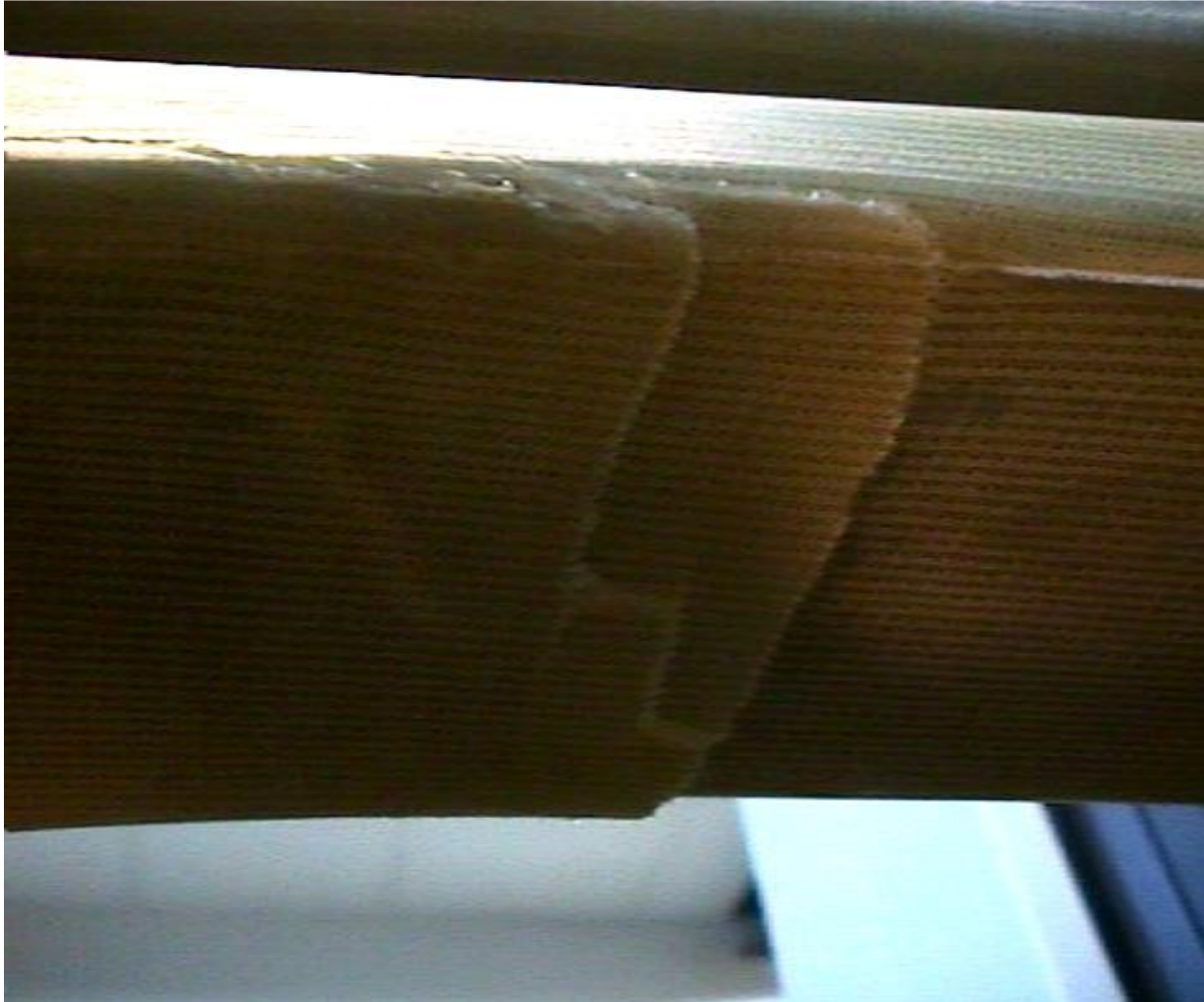

Fig 2.3 Delamination at the interface of the fibers coming back from the eye end to the fibers beneath. [1]

The delamination shown in Fig. 2.3, started at comparatively low loads and propagated until the fibers coming back from around the eye separated completely with the body of the top leaf.

Design with transverse wrap [1]

This design is to wrap the section where high interlaminar shear stress occurs with transverse bandage. It was found that the transverse did not stop the delamination and because of bending stiffness mismatch between the wrap and the spring stiffness, delamination occurs at the interface of two materials.

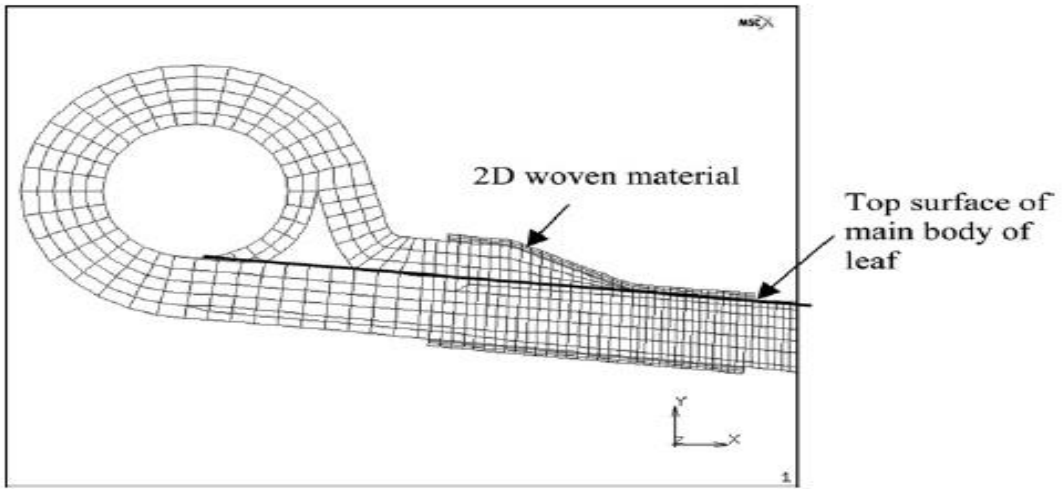

Fig 2.4 Transverse wrapping [1]



Fig 2.5 Delamination of wrapping layers [1].

Third design was proposed to leave open eye end and thus avoid the local high interlaminar shear stress between fibers coming from the eye end or the transverse wrap and the spring body.

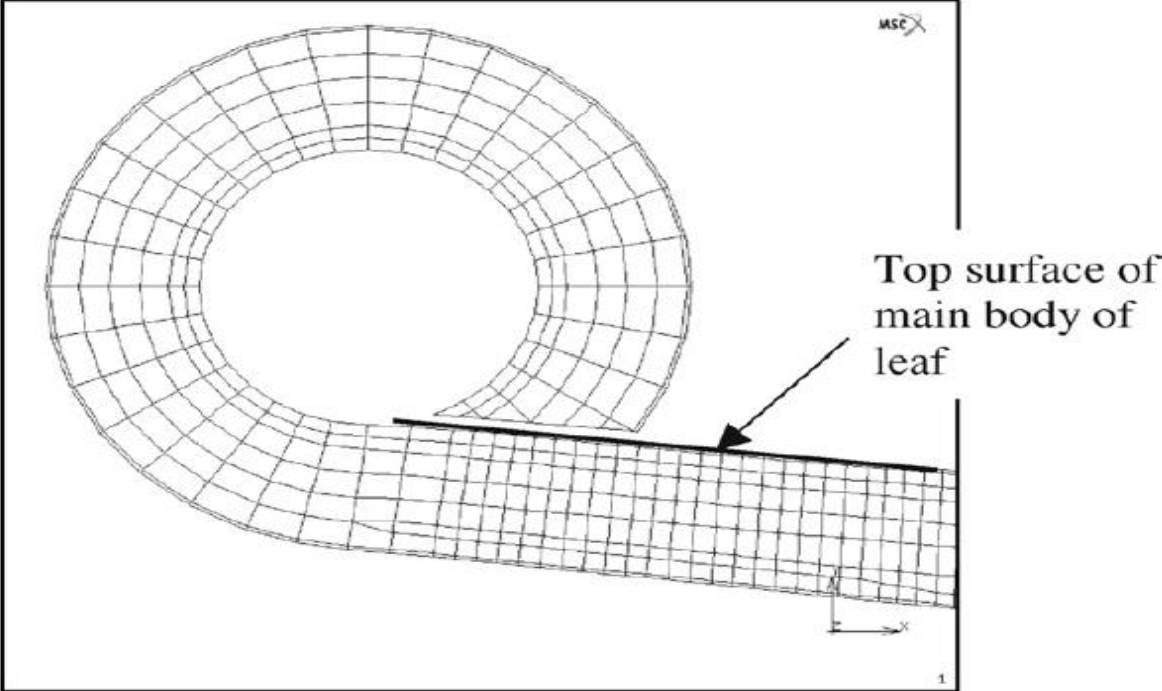

Fig 2.6 Design of open eye end [1].

Chapter 3

Calculations and CAD geometry

3.1. Calculations of leaf spring

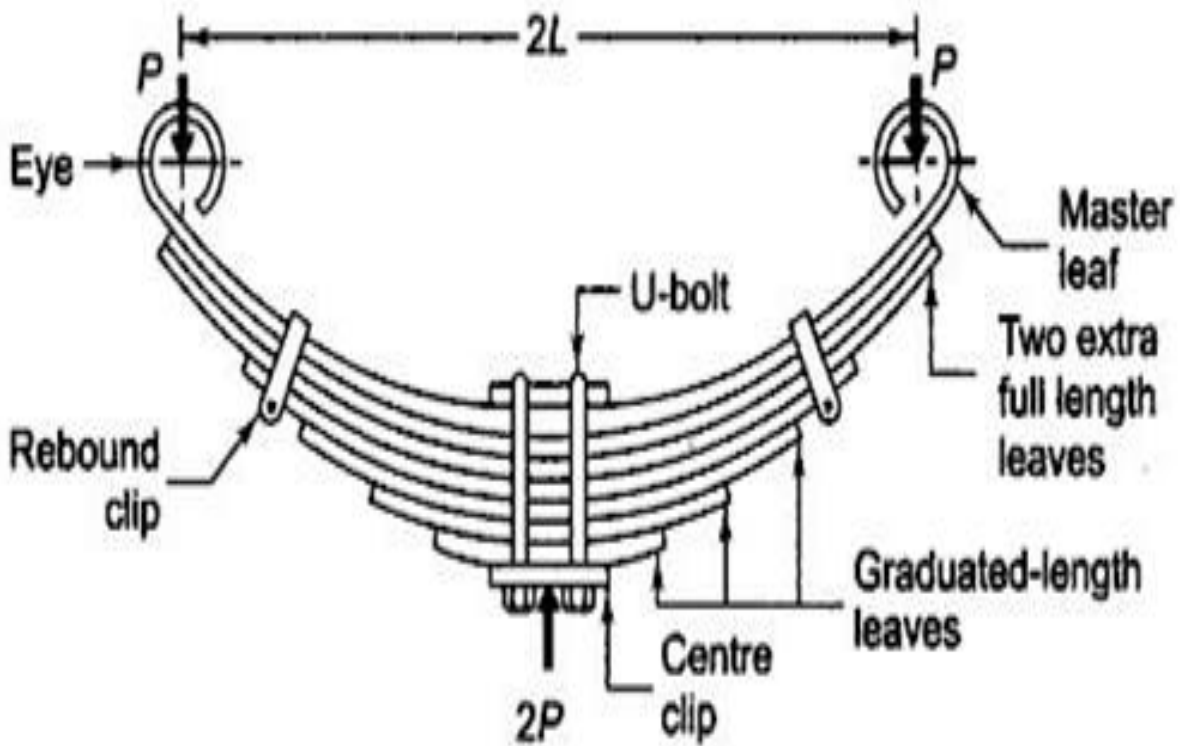

Fig 3.1 Leaf spring [15]

$2L_1$ – Overall length

L – distance between U bolts (Ineffective length)

N_f – number of full length

N_g – number of graduated leaf

Effective length(EL) = $2L_1 - (2/3) L$

Length of smallest leaf = $(EL * 1/n - 1) + \text{Ineffective length}$

Length of next leaf = $(EL * 2/n - 1) + \text{Ineffective length}$

Length of (n-1) leaf = $(EL * (n-1)/n - 1) + \text{Ineffective length}$

Length of master leaf = $2L_1 + 2\pi(d+t) * 2$

d = diameter of eye.

T = thickness of leaf.

Max bending stress = $(6 * F * L_1) / (n * b * t^2)$

Max deformation = $(6 * F * L_1^3) / (E * b * t^3)$

Relation between curvature I and chamber $(Y) - Y(2R+Y) = L_1$

3.2. Load Calculations of leaf spring [3]

Consider a following example to calculate the force acting on the leaf.

Weight of car = 700 kg.

Maximum load carrying capacity = 1000 kg.

Total weight = 1700 kg = $1700 * 9.8 = 16677$ N.

For four wheeler vehicle

Total weight by leaf = $16677/4 = 4169$ N.

But $2F = 4167$

$F = 2084$ N.

3.3 CAD geometry and dimensions.

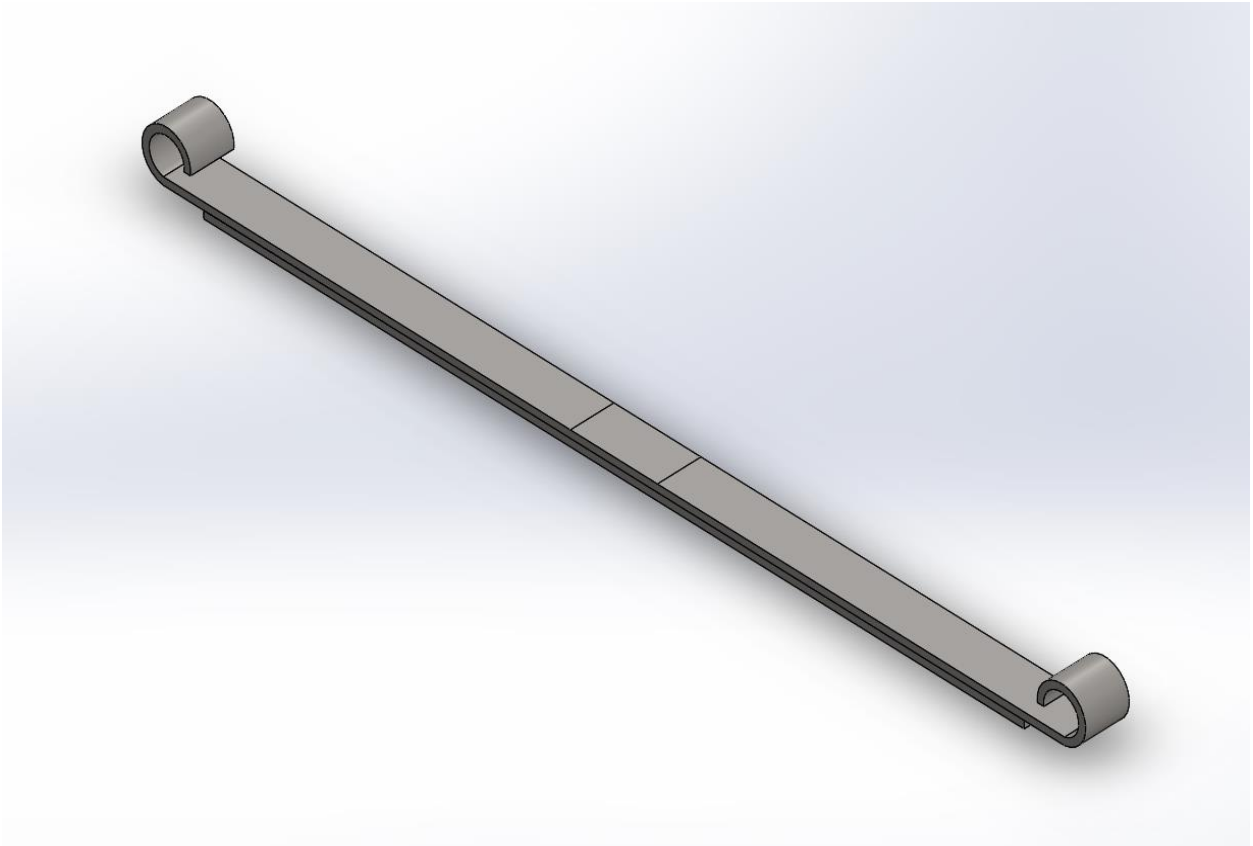
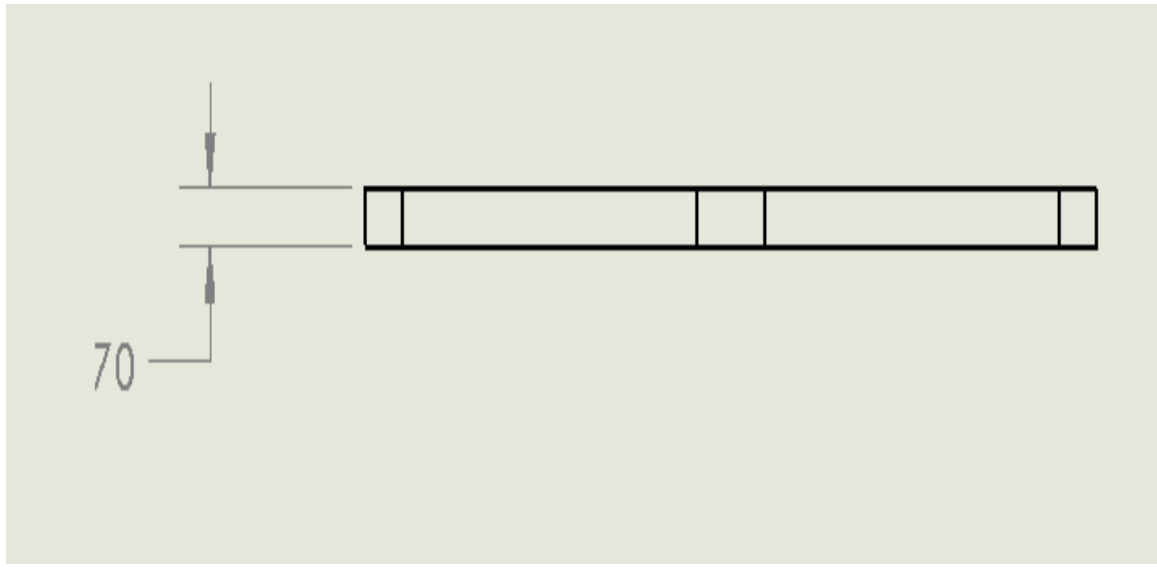
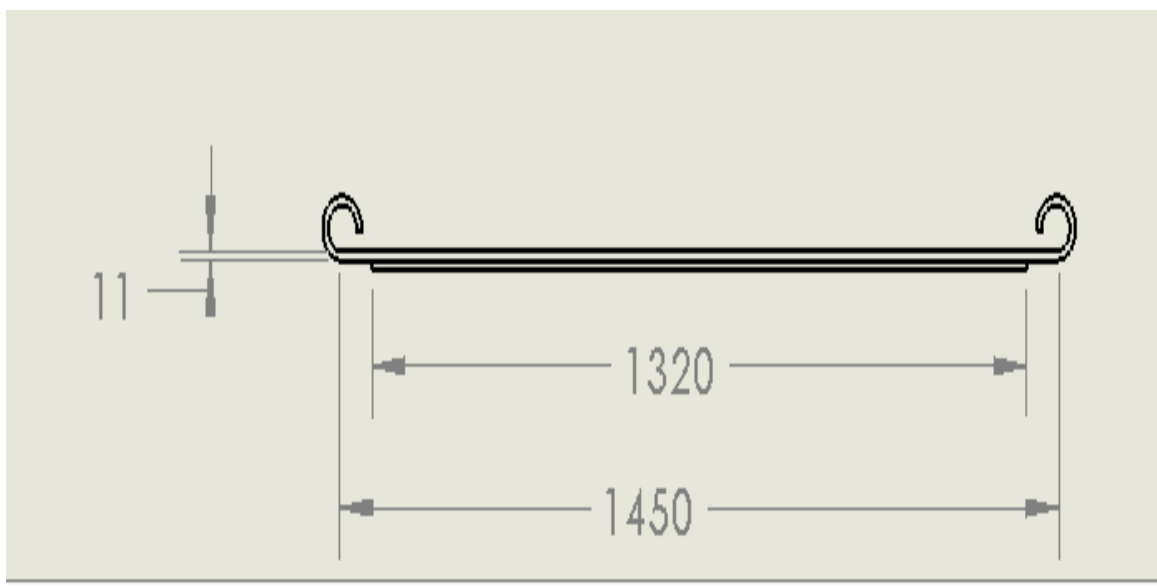

Fig 3.2 Cad model of leaf spring



(a)



(b)

Fig 3.3 Dimensions of Leaf spring

Overall Length = 1450 mm.

Length of the next leaf = 1320 mm.

Width of the leaf = 70 mm.

Thickness of the leaf = 11 mm.

3.4 Boundary conditions.

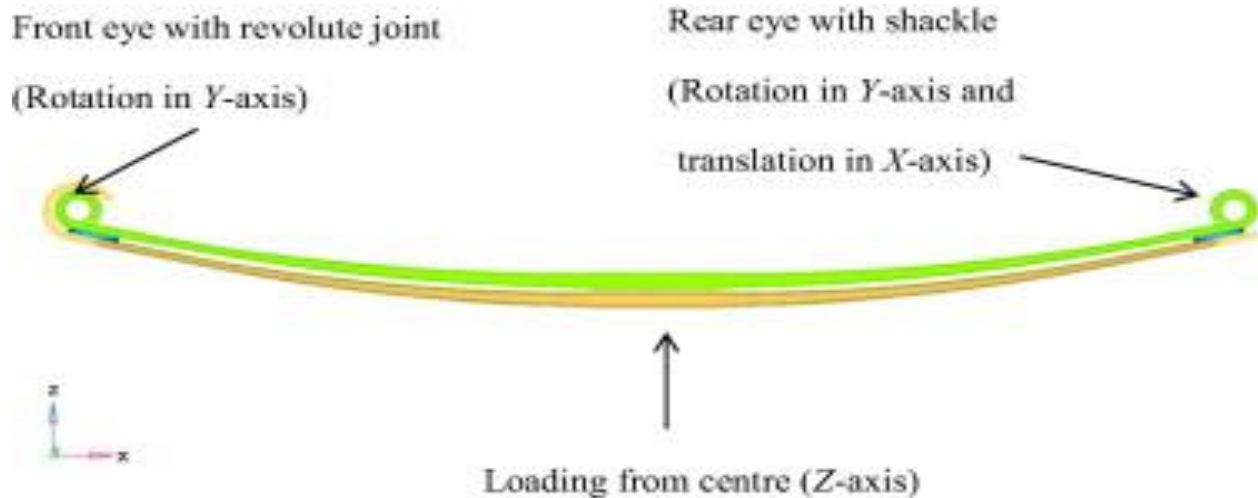

Fig 3.4 Boundary condition of leaf spring [18]

There are mainly two ways of attaching leaf springs to the frame of the vehicle

- 1) Both the ends are directly attached to the frame of the body. In this case at both the ends only rotation motion in one direction is permitted while all the other rotation and translation motion are restrained.
- 2) In the second case, one end is attached to the frame of the body while the other end is attach to the shackle (mostly the rear end). In this case, at the shackle end translation in X axis and rotation moment in Y axis are permitted while at the other end only rotation moment along Y axis permitted.

The advantage of attaching the leaf to the frame of the vehicle through shackle is that it provides additional motion i.e. translational motion along X axis and the advantage is that it provides smooth springiness.

3.5 Meshed model [19].

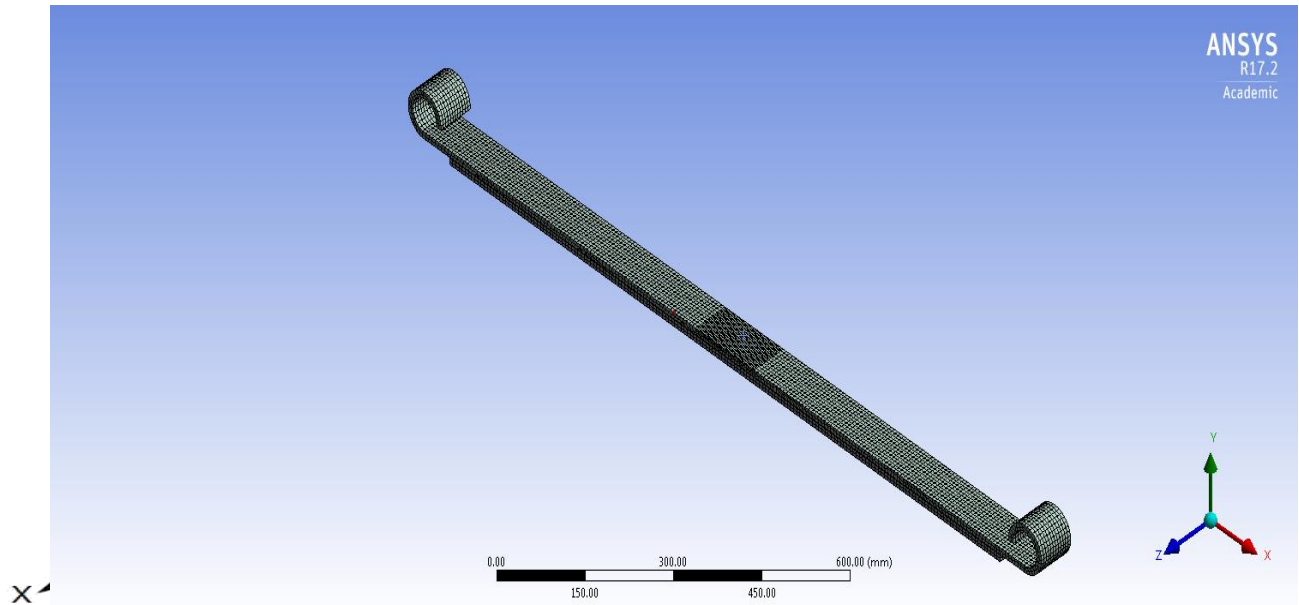

Fig 3.5 Meshed model

The CAD model was meshed using Slid brick elements. SOLID186 is a higher order 3-D 20-node solid element that exhibits quadratic displacement behavior. 20 nodes having three degrees of freedom per node define the element: translations in the nodal x, y, and z directions. The element supports plasticity, hyper elasticity, creep, stress stiffening, large deflection, and large strain capabilities. It also has mixed formulation capability for simulating deformations of nearly incompressible elastoplastic materials, and fully incompressible hyper elastic materials.

Meshing was done by using body sizing and by use of hex dominant method with element type as all quad. Mid-side element nodes are selected to KEPT. This generates a mesh

with brick elements particularly SOLID 186. SOLID186 is a higher order 3-D 20-node solid/brick element. The middle mesh was generated using refinement of the particular area.

Fig 3.6 SOLID 186[19]

In order to take into account non linearities Large Deflection were ON.

The mesh data is given below.

Element shape = 8 node quad

Element size = 5mm.

Number of elements = 41922

Number of nodes = 218261

There are many materials used for manufacturing of conventional steel leaf springs for example 65Si7, EN45, EN45A, 60Si7, EN47, 50Cr4V2, 55SiCr7. But for my research work I have taken 65Si7 as my material for conventional steel leaf spring material.

The table below shows the material properties of 65Si7

PARAMETER	VALUE
Young Modulus I	$2.1 \cdot 10^5$ MPa
Poisson ratio	0.266
UTS	550 MPa
YTS	250 MPa
Density	7860 kg/m ³

Table 4.1 Material Properties of 65Si7

For research work I have taken into consideration four composite FRP materials. They are E glass epoxy UD, S glass epoxy UD, Carbon fiber and Kevlar.

Here are the following characteristics and properties of these materials

- 1) Glass fibers – They are most common of all reinforcing fibers for polymeric matrix composites. Main advantages are low cost, high tensile strength, high corrosion resistance and excellent insulating properties. Main disadvantages are low tensile modulus and high

density. The two types of glass fibers used are E-glass and S-glass. E-glass is the cheapest among all the reinforcing fibers, while S glass has highest tensile strength among all the fibers. It is mainly used in aircraft component and missile casings.

- 2) Carbon fibers – The advantages are high tensile strength to weight ratio as well as tensile modulus to weight ratio, very low coefficient of linear thermal expansion, high fatigue strength and high thermal conductivity. The disadvantages are low strain to failure, low impact resistance, and high electrical conductivity. Their high cost has so far excluded them from widespread applications. They are mostly used in aerospace industry, where weight saving is considered more critical than cost.
- 3) Kevlar fibers – Kevlar 49 is the trade name of one of the aramid fibers. Aramid fibers are highly crystalline aromatic polyamide fibers that have lowest density and highest tensile strength to weight ratio among all the fibers in use. They are used in many marine and aerospace applications.

Properties	E glass	S glass	Carbon fiber	Kevlar
E11 (MPa)	45000	50000	209000	95710
E22 (MPa)	10000	8000	9450	104500
G12 (MPa)	5000	5000	5500	25080
V12	0.3	0.3	0.27	0.34
Density	2000	2000	1540	1402
UTS	1100	1700	1679	1600
UCS	675	1000	893	517

Table 4.2 Material properties of E/S glass/Carbon fiber/Kevlar

For my research I have assumed fiber volume fraction $V_f = 60\%$. For this value of V_f I have calculated the values of longitudinal and transverse elastic modulus, shear modulus and Poisson ratio.

Properties	E/epoxy	S/epoxy	C/epoxy	K/epoxy
E_{11} (MPa)	28200	31200	126600	58626
E_{22} (MPa)	5172	4800	5080	7190
G_{12} (MPa)	5362	5362	3608	2119
V_{12}	0.25	0.25	0.3	0.34
V_{23}	0.43	0.43	0.4	0.25

Table 4.3 Material properties of E/S glass/Carbon fiber/Kevlar for $V_f = 60\%$

Chapter 5

Results

5.1 Results of 65Si7 stress and deformation

In this section bending stress (Von Mises stress) and deformation of 65Si7 material is calculated using ANSYS 17.2 software.

For 2000 N

Stress

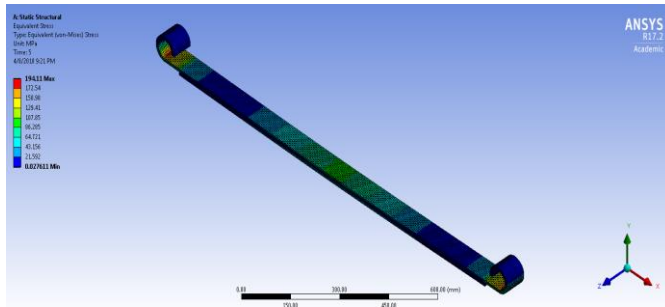

Deformation

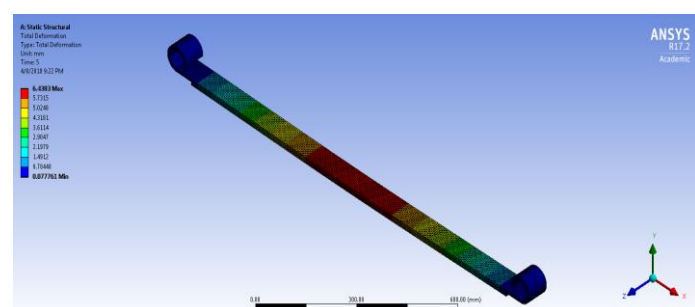

For 3000 N

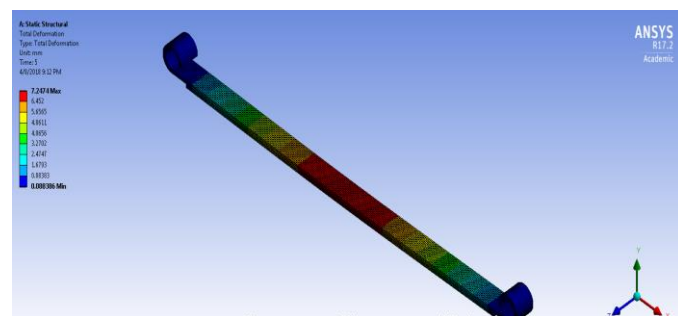
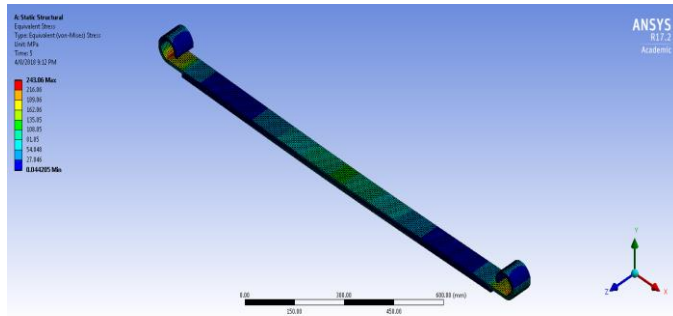

For 4000 N

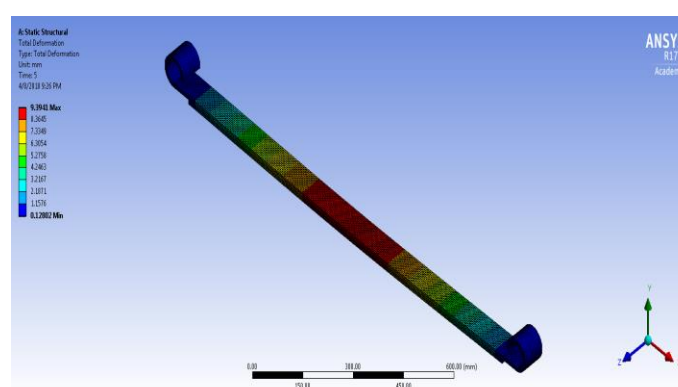
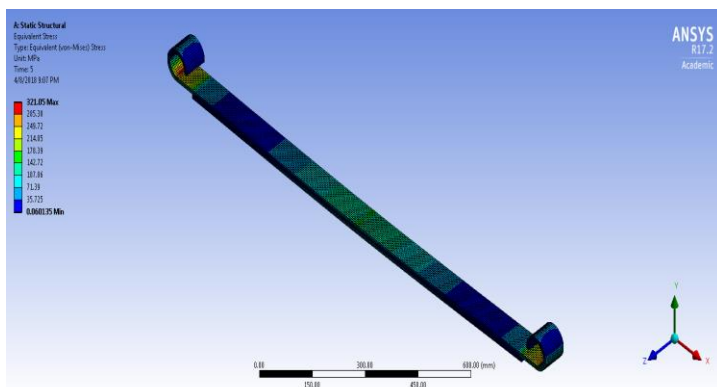

For 5000 N

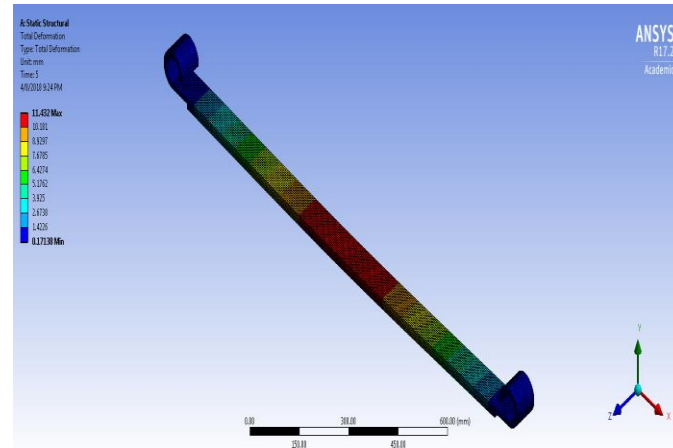
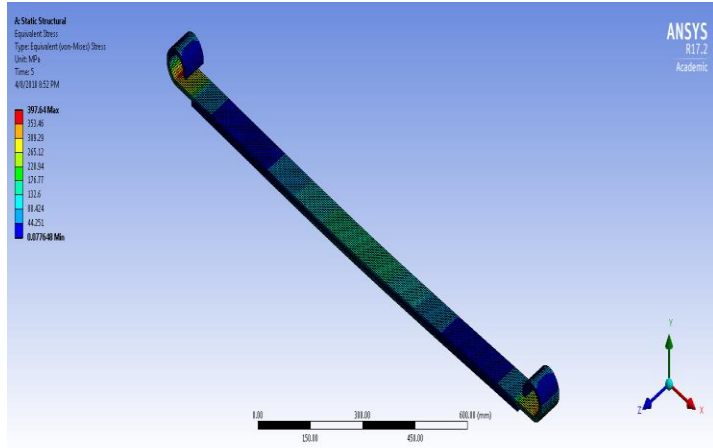

Fig 5.1 Results of Static analysis of 65Si7

Results of 65Si7

Loads	Stress(MPa)	Deformation(mm)
2000	163.61	4.97
3000	243.06	7.24
4000	321.05	9.39
5000	397.64	11.4

Table 5.1 Results of 65Si7

5.2 Results of composites materials stress and deformation

As discussed earlier that for my research work I have taken four composites fiber and compared the deformation and stress.

Following table shows comparison of stress.

LOADS	E GLASS	S GLASS	CARBON FIBER	KEVLAR
2000	155.62	160.61	173.1	171.5
3000	227.01	230.01	255.74	250.54
4000	294.38	297.21	334.98	327.25
5000	359.61	364.79	419.40	403.21

Table 5.2 Stress comparison of E/S glass/Carbon fiber/Kevlar

From the table we can conclude that by comparing stresses of all the four composites materials, we obtain least stress for E glass epoxy UD.

Following table shows comparison of deformation

LOADS	65Si7	E GLASS	S GLASS	CARBON FIBER	KEVLAR
2000	4.97	20.53	18.97	3.88	4.40
3000	7.24	28.32	26.30	5.87	6.25
4000	9.39	35.23	32.75	8.20	9.01

5000	11.4	41.32	38.65	10.76	11.01
------	------	-------	-------	-------	-------

Table 5.3 Deformation comparison of 65Si7/E/S/Carbon fiber/Kevlar

Maximum deformation is obtained for E Glass Epoxy UD and minimum is for carbon fiber. We can conclude that carbon fiber is stiff among all of the above material, while E glass is least stiff material.

5.3 Design change

Firstly, constant thickness and constant width design was analyzed using ANSYS. Now the design is changed to constant thickness but the width is varied. The width varies hyperbolically, it is maximum towards the eye and is minimum in the center section of the leaf.

This design concept can be easily understood by modelling the spring as a simply supported beam with central vertical load P. If the beam has a rectangular cross section, the maximum normal stress at any location x in the beam is given by

$$\sigma = (3Px)/bt^2$$

Where b and t are width and thickness of the beam respectively.

For a uniform cross-sectional beam, $bt = \text{constant} = A_0$. Furthermore the beam is designed for a constant maximum stress, σ . Thus by using above equation, we can write equation for width variation as

$$b = (A^2\sigma)/3Px$$

5.4 Comparison of stress and deformation for design change

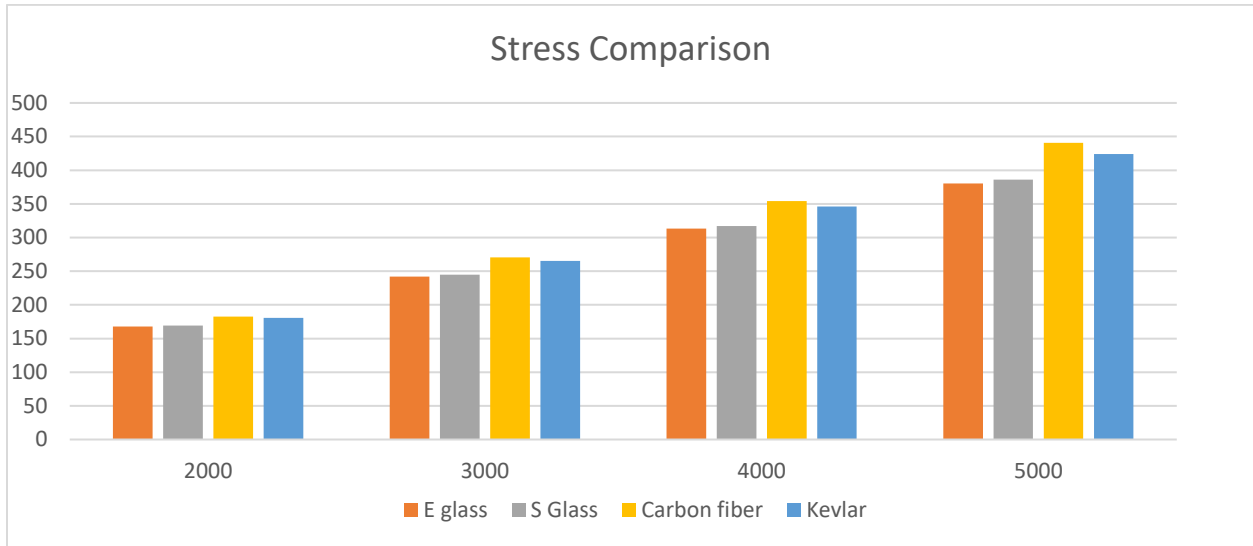

Fig 5.2 Stress comparison for design change

After changing the design as per the above formula, stress level is least in E glass epoxy while they are maximum in the carbon fibers.

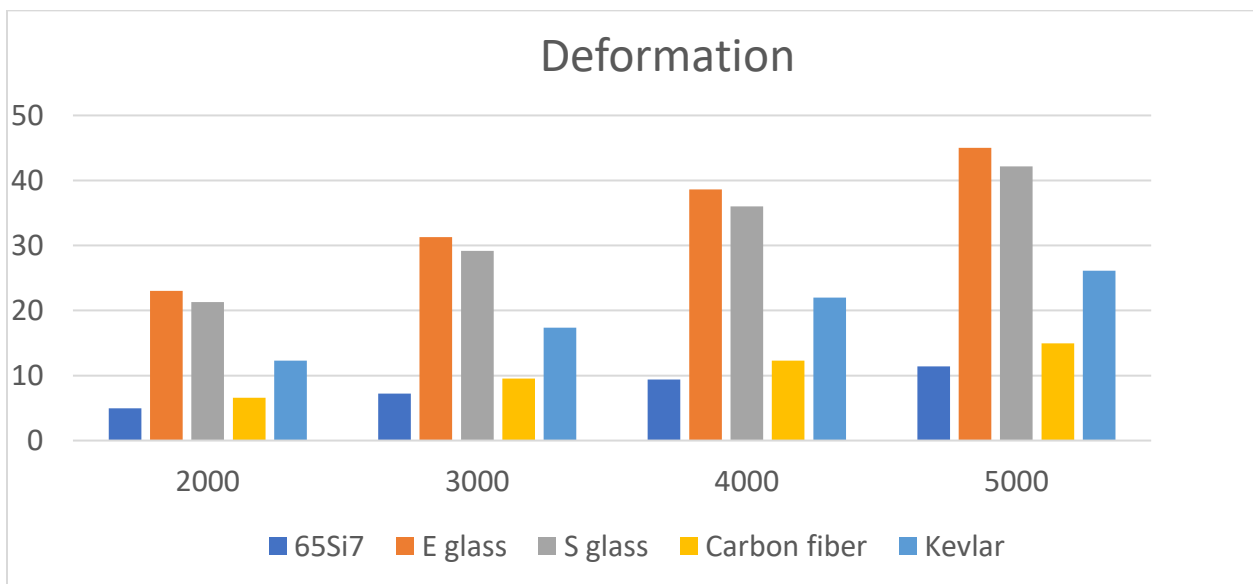

Fig 5.3 Deformation comparison for design change

The deformation is maximum for E glass epoxy UD while it is minimum for carbon fiber. Carbon fiber is the stiffest material of all four. As the stress level are minimum for E glass epoxy UD, for further analysis I have taken only E glass epoxy UD as composite material.

But in order to find the stress difference in both of the composite leaf spring design, both of the design were compared for stress. The following graph shows differences in the stress level between both of the designs of composite leaf springs.

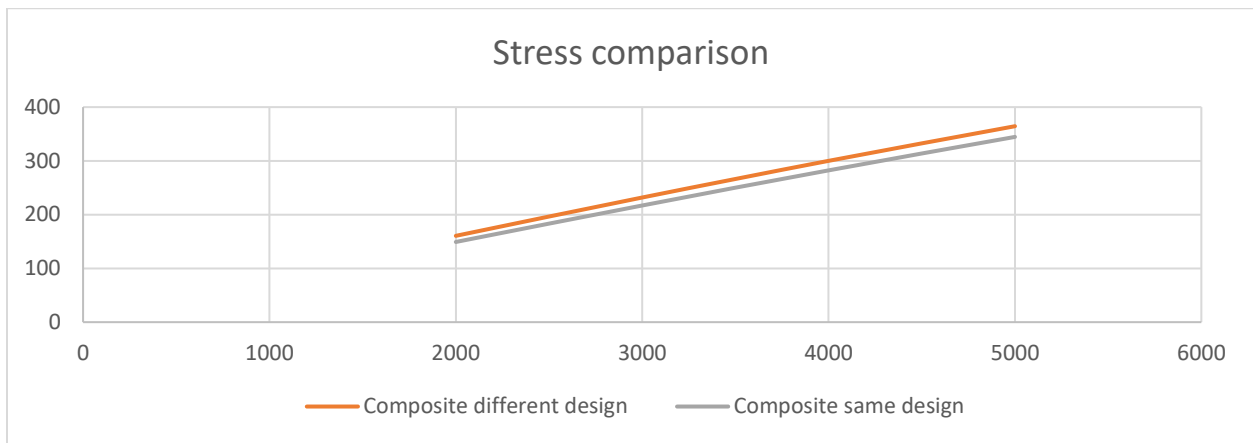

Fig 5.4 Stress comparison of different design of E glass epoxy leaf spring

The stress level in the varying width design is slightly more than that of constant width design. But the most important factor is of weight. As weight reduction while keeping the same strength of the component is the utmost priority of the manufactures today in most of the industries, it is very crucial to reduce the weight as it can lead to better fuel efficiency, lesser emission of gases leading to less pollution.

Weight comparison is done. Weight of steel leaf spring, composite leaf springs of both design and it can found that by using composite materials instead of conventional steel material, the weight is reduced by approximately 22 %. Adding to this, by comparing it with the composite leaf spring with varying width design, the weight is reduced by approximately 49 %.

Thus we can conclude that by changing the design though there is increase in the stress level but the weight is reduced drastically.

5.5 Stress analysis in each ply

Stress analysis for each ply was done in ANSYS and it was noted that the stress in the innermost layer was maximum. The reason is that as the composite are strong in tensile direction while weak in compressive direction. When the load is applied, the innermost layer is in compression while the outermost layer is in tension. Also other graph of stress analysis of each ply shows that after ply no 6 which is 90-degree ply there is a sudden increase in the stress level. Below are the following two graphs of stress analysis in each ply.

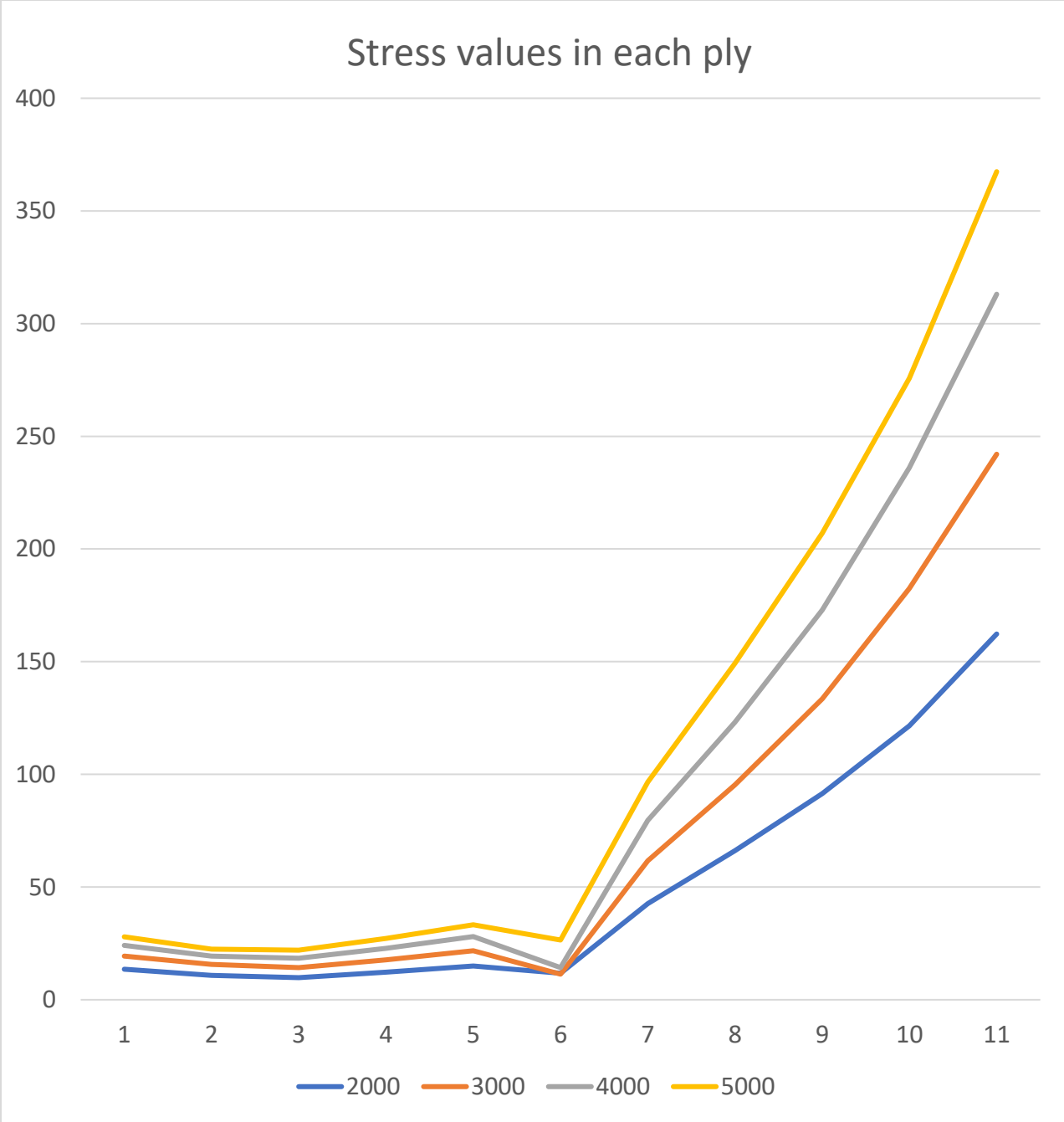

(a)

PLY NUMBER	2000 N	3000 N	4000 N	5000 N
1	13.49	19.39	23.98	28.56
2	10.85	15.68	19.56	22.36
3	9.80	14.63	18.36	22
4	12.18	17.89	22.25	27.94
5	14.92	21.04	27.68	33.04
6	11.78	11.17	14.48	26.14
7	42.70	61.03	79.28	96.82
8	66.75	94.86	122.65	148.86
9	91.89	133.73	172.81	207.76
10	121.72	182.12	236.36	275.97
11	162.61	242.87	313.05	367.53

(b)

Fig 5.5 Stresses in each ply in E glass epoxy leaf spring (a) and (b)

5.6 Factor of safety [18]

Factors of safety (FoS), is also known as **safety factor (SF)**, is a term describing the load carrying capacity of a system beyond the expected or actual loads. Essentially, the factor of safety is how much stronger the system is than it needs to be for an intended load. It is also defined as the ratio of yield stress to the working stress. By this definition, a structure with a FOS of exactly 1 will support only the design load and no more. Any additional load will cause the structure to fail. A structure with a FOS of 2 will fail at twice the design load. This is one of the most area of designing. Safety is an essential aspect of design.

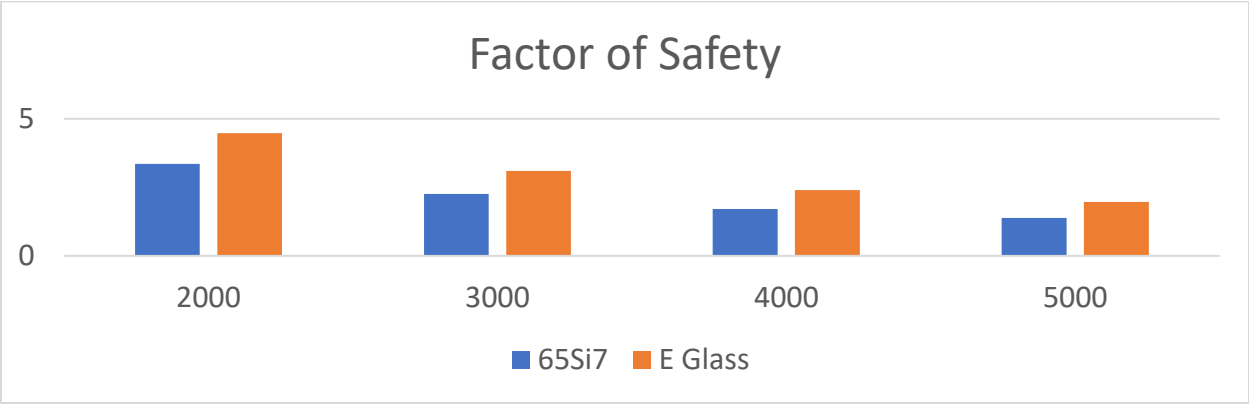

Fig 5.6 Comparison of Factor of Safety

After comparing the factor of safety of the steel leaf spring and composite leaf spring, it can be concluded that composite leaf spring is more safe than the steel leaf spring.

5.7 Natural frequency

To provide ride comfort to passenger, leaf spring has to be designed in such a way that its natural frequency is maintained to avoid resonant condition with respect to road frequency. The road irregularities usually have the maximum frequency of 12 Hz. Leaf spring should be designed to have a natural frequency, which is away from 12 Hz to avoid the resonance.

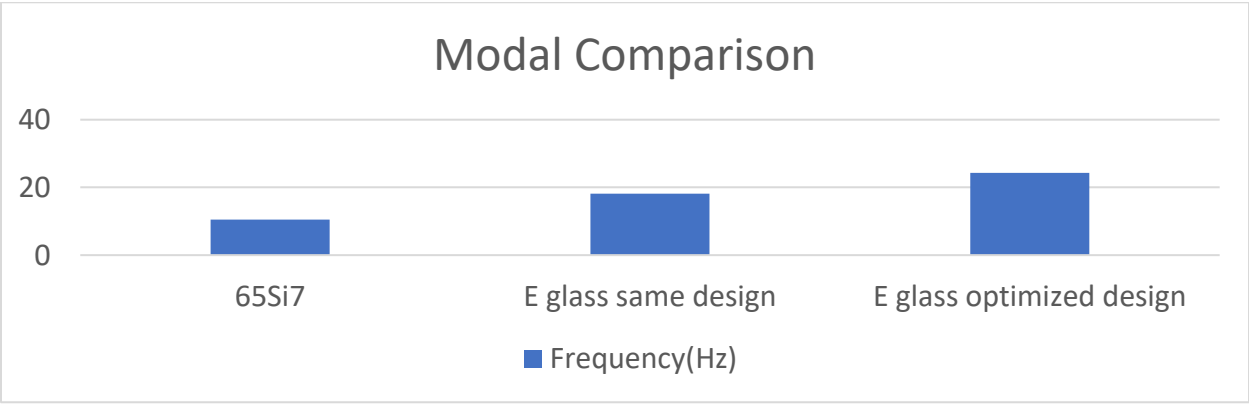

Fig 5.7 Comparison of natural frequency

From the above graph we can conclude that for steel leaf spring the natural frequency is very close to the natural frequency of the road irregularities, thus resonance occur which can be very devastating.

Both the designs of composite leaf springs have natural frequency very far from the natural frequency of the road irregularities. The varying width composite design's natural frequency is 228.57%.

5.8 Design with rubber

In this design, rubber with thickness 3mm between the main leaf and the graduated leaf. The reason for thickness of 3 mm is that the for 1mm and 2mm thickness, the rubber is crushed when heavy load is applied to the springs. The main idea for inserting the rubber is to increase the heat dissipation in the working condition, as there is sliding motion between the leaves.

5.9 Strain energy [3]

Materials constitute nearly 60 to 70% of vehicle cost and contribute to the quality and performance of vehicle even a small amount in weight reduction of vehicle, may have a wider economic impact. The strain energy of the material becomes a major factor in designing the springs. The relationship of the specific strain energy can be expressed as, $U = \sigma^2 / \rho E$.

Where σ is the strength, ρ the density and E the Young's modulus of the spring material. The stored elastic strain energy in a leaf spring varies directly with the square of maximum allowable stress and inversely with the modulus of elasticity both in the longitudinal and transverse directions. The composite materials have more elastic strain energy storage capacity and high strength-to-weight ratio as compared to those of steel. Composite materials are proved as suitable substitutes for steel thus composite material have been selected for leaf spring.

65Si7 (J)	E GLASS (J)	65Si7 + RUBBER (J)	E GLASS + RUBBER (J)
11.9	21.55	26.38	30.11

Table 5.4 Comparison of Strain energy

5.10 Fatigue life analysis [17].

From a certain point of view, fatigue in composites and fatigue in metals are similar: both begin with damage initiation, followed by damage propagation, and end in ultimate failure. Fatigue life N_f , or number of cycles to failure, for both can be thought of as the sum of the cycles during damage initiation N_I and the cycles during damage propagation N_p .

$$N_f = N_I + N_p$$

One difference is in the relative time spent in each phase. For metals, a significant portion of the fatigue process is spent propagating a single crack. Damage initiation is usually ignored because generally, many defects such as grain boundaries and dislocations exist in the material that can replicate new defects. The propagation phase is longer because metals strain hardens. As a crack attempts to propagate through the metal, plasticity occurs at the crack tip causing crack blunting and strain hardening. The process of crack blunting, strain hardening, and crack progress can be repeated for many thousands of cycles. So in the case of metals, Equation is simplified to

$$N_f = N_p$$

The amount of crack growth during each cycle of the propagation phase is often described with an empirical law, such as the Paris Law.

For a composite, such as a unidirectional laminate, strain hardening is negligible. This makes the propagation phase of the fatigue life much shorter than the damage initiation phase. This happens because damage progresses very quickly to ultimate failure once a defect of sufficient size is nucleated. Thus, for fiber-reinforced polymer (FRP) composites, Equation is simplified to

$$N_f = N_I$$

The initiation of damage in a FRP is governed by a kinetic process of microcrack accumulation. When a critical density of microcracks is achieved, a macroscopic crack forms. This type of fatigue failure can be modeled with the kinetic theory of fracture (KTF). In the case of a FRP composite material, stresses in the polymer matrix are not the same as the composite stresses. To apply KTF to the polymer, a methodology for determining matrix stresses from composite level stresses must be implemented. Therefore, we employ multicontinuum theory (MCT) to extract these polymer matrix stresses from composite stresses, as described earlier (The MCT Decomposition), and use KTF to predict the matrix (and therefore composite) fatigue life.

Results of fatigue life of 65Si7

Number of cycles to failure = 95628.

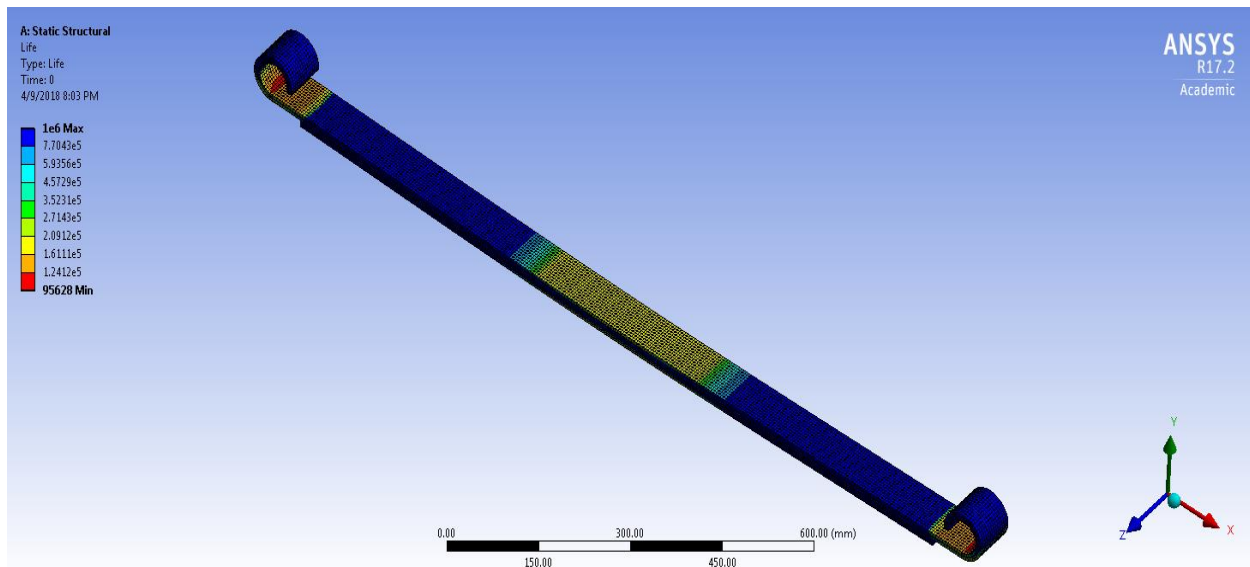

Fig 5.8 Result of fatigue life of 65Si7

B) Results of fatigue life of E glass epoxy UD

1. Analytical method

For E glass epoxy Hwang and Han developed an analytical fatigue model to predict the number of cycles to failure.

Hwang and Han Relation

$$N = \{B(1-r)\}^{1/c}$$

Where

$$B = 10.33$$

$$c = 0.14012$$

$$r = \sigma_{\max} / \sigma_u$$

σ_{\max} = maximum stress

σ_u = ultimate tensile strength

For 5000 N load

$$N = 2.02E+05 \text{ cycles.}$$

2. FEM method

Miner rule's

$$D = (n_1\sigma / N_1\sigma) + (n_2\sigma / N_2\sigma) + (n_3\sigma / N_3\sigma)$$

$n_1\sigma$ = actual number of cycle at or below 1σ level

$n_2\sigma$ = actual number of cycle at or below 1σ & 2σ level

$n_3\sigma$ = actual number of cycle at or below 2σ & 3σ level

$N_1\sigma, N_2\sigma, N_3\sigma$ = allowable number of cycle at $1\sigma, 2\sigma, 3\sigma$ stress level.

Steps required to calculate fatigue life

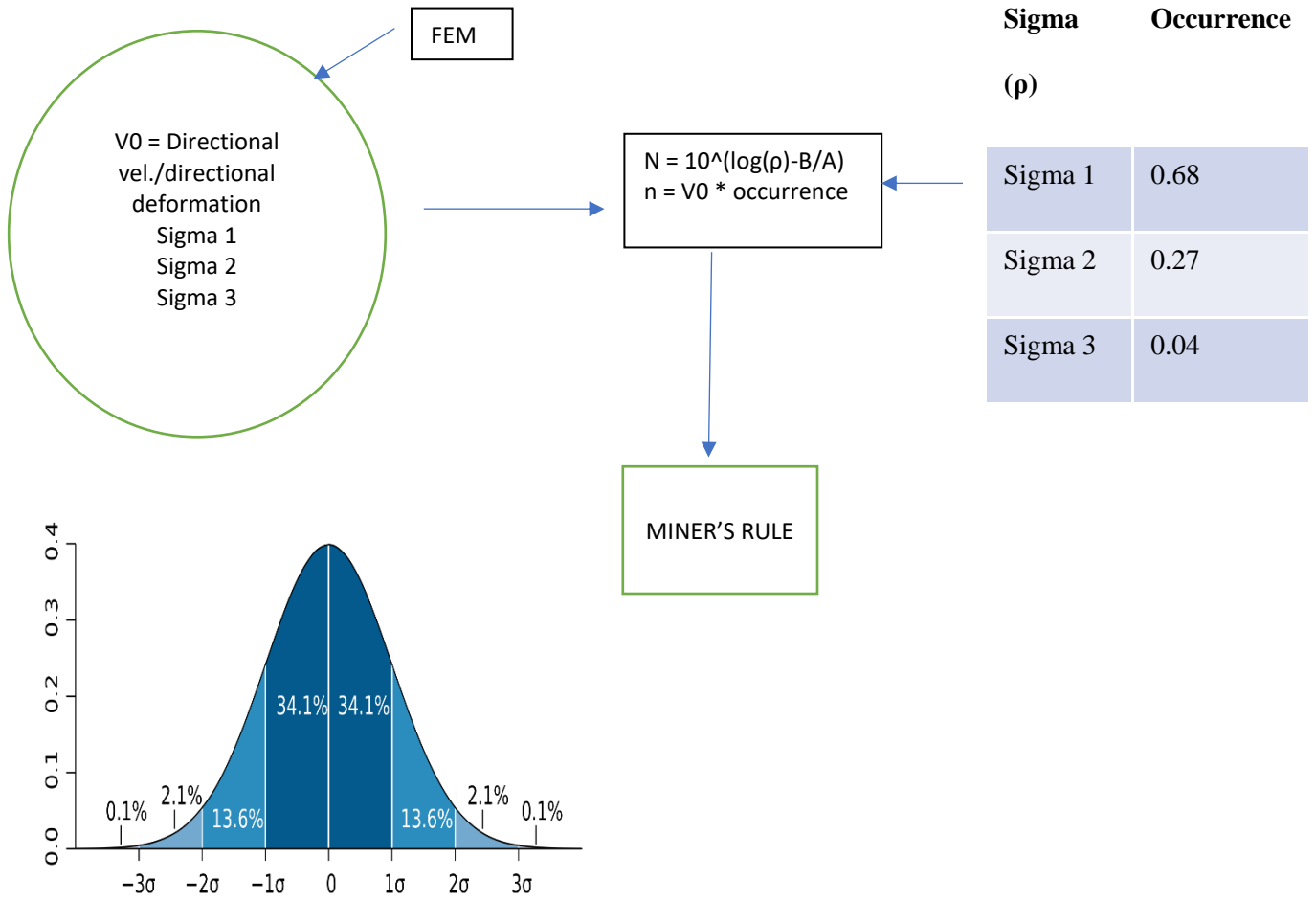

LIFE OF E GLASS EPOXY COMPOSITE = $2 * 10^5$ CYCLES.

Future Work

1. Use of Nanocomposite materials in designing and manufacturing of leaf spring can further result into reduction in weight, which can result into increase in fuel efficiency.
2. Sophistication in manufacturing process of composites. Almost all the failure occurs due to defects or error in the manufacturing process of the composites.
3. Additive manufacturing is one of the most recent research field. Immense research is going on in the field of 3D printing composites. Manufacturing composite leaf spring will further be more advantageous than the conventional method used for manufacturing composites.
4. Design can further be optimized, by varying both width and thickness of the leaf spring further weight reduction is possible.
5. For heavy axle loading application, only composites are not very effective. In order to take into account this drawback hybrid composites can be used. There will be increase in the overall weight of the component but the load carrying capacity will increase drastically.

Conclusion

1. For the same design for conventional steel and E glass epoxy composite leaf spring, the weight reduction obtained is about 22%. But by changing the design weight reduction obtained is about 48%.
2. Strain energy, one of the most important parameter taken into account while designing springs. Strain energy is more in case of E glass epoxy composite leaf spring as compared to that of the conventional steel leaf spring.
3. Factor of safety of E glass epoxy composites is 1.42 times as that of conventional steel. Composite leaf spring is more safe than that of the conventional steel leaf spring.
4. If the natural frequency of the road irregularities matches the natural frequency of the leaf spring, resonance will occur. The natural frequency of the conventional steel leaf spring is very close to the natural frequency due to road irregularities. The natural frequency of the varying width composite leaf spring is 2.18 times as that of the conventional steel leaf spring.
5. Toughness of the leaf spring is increased with the insertion of the rubber material in between the leaf.
6. Fatigue life of the E glass epoxy composite leaf spring is approximately twice as that of the fatigue life of the conventional leaf spring. In simple terms E glass epoxy composite leaf spring is more durable than the conventional steel leaf spring.
7. Addition of rubber layer in between the leaf increases the energy absorption capacity of the leaf as a whole. There is 10% increase in the energy absorption capacity of the leaf spring by inserting 1 rubber layer of thickness 3mm.

References

- [1] J.P. Hou, J.Y. Cherruault, I. Nairne, G. Jeronimidis, R.M. Mayer, Evolution of the eye end design of composite leaf spring for heavy axle loading. Published by Elsevier Ltd 2005.
- [2] Ashish V. Amrute, Edward Nikhil Karlus, R.K. Rathore. Design and assessment of multi leaf spring.
International journal of research in aeronautical and mechanical engineering, Vol.1 Issue.7, November 2013.
- [3] B.B. Deshmukh, Dr.S.B.Jaju, Design and analysis of Glass fiber reinforced polymer(GFRP) leaf spring. Fourth International Conference on Emerging Trends in Engineering & Technology, 2011
- [4] Eckold, G. Design and Manufacture of Composite Structures. Cambridge: Woodhead Publishing Ltd., 1994.
- [5] Nawy, E. G. Fundamentals of high-performance concrete. Second. Canada: JohnWiley & Sons, 2001.
- [6] Matthews, F. L., et al. Finite Element Modelling of Composite Materials and Structures. Cambridge: Woodhead Publishing Ltd., 2000.
- [7] Agarwal, B. D., et al. Analysis and Performance of Fiber Composites. New Jersey: John Wiley & Sons, 2006.
- [8] Staab, G. H. Laminar Composites. Boston: Butterworth-Heinemann, 1999.
- [9] Jones, R. M. Mechanics of Composite Materials. Second Edition. Philadelphia: Taylor & Francis, Inc., 1999.
- [10] Kollar, L. P. and Springer, G.S. Mechanics of Composite Structures. Cambridge: Cambridge University Press, 2003
- [11] Kaw, A. K. Mechanics of Composite Materials. Florida: CRC Press LLC, 1997.
- [12] Owen, M. J. "Fatigue Damage in Glass-Fiber-Reinforced Plastics." Krock. Composite Materials (Volume 5: Fracture and Fatigue). Ed. Broutman, L. J. New York: Academic Press, 1974. 313-340.

[13] Kaechele, L. E. “Review and Analysis of Cumulative Damage Theories.” The Rand Corporation, 1963.

[14] Broutman, L. J. and Sahu, S.A. “Progressive Damage of a Glass Reinforced Plastic During Fatigue.” 24th Annual Technical Conference, Reinforce Plastics/Composites Div. SPI, 1969.

[15]https://www.alibaba.com/product-detail/China-leaf-spring-rolling-machine-for_60632016329.html

[16] Himanshu Arun Raut, Static and dynamic FEA analysis of composite leaf spring,2016.

[17]<https://knowledge.autodesk.com/support/helius-pfa/learn-explore/caas/CloudHelp/cloudhelp/2017/ENU/ACMPAN/files/GUID-061F06B7-EE52-4E0B-B2CB-5DFE6CF903EE-htm.html>

[18] Y. S Kong, M.Z. Omar, L.B. Chua, S. Abdullah, Fatigue life prediction of parabolic leaf spring under various road conditions, 2014.

[19] <https://www.wikipedia.org/>

Biographical Information

Prashik Sunil Gaikwad was born in Pune, Maharashtra, India in February 1994. He received his Bachelors in Mechanical Engineering degree in August 2015. During his undergrad, he had interest in automobile (designing) and also participated in SAE BAJA in 2015. He enrolled into Masters of Science in Mechanical and Aerospace Engineering program at the University of Texas at Arlington in Fall 2016.

He started working under the guidance of Dr Andrey Beyle from Fall 2017, whose expertise is in composite materials. He is proficient in ANSYS workbench, Ansys PrePost, Solidworks and AutoCad. He was also teaching assistant of MAE CAD LAB from September 2017 to May 2018 at the University of Texas at Arlington.