

Robust Predictive Analytics for Determining Acclimation parameter of IT Equipment

By

Premsanth Sadasivam

Presented to the Faculty of the Graduated School of
The University of Texas at Arlington in Partial Fulfillment
Of the Requirement
for the Degree of

MASTER OF SCIENCE IN MECHANICAL ENGINEERING

THE UNIVERSITY OF TEXAS AT ARLINGTON

MAY 2018

Copyright © by Premsanth Sadasivam 2018

All Rights Reserved



Acknowledgements

I would like to take this opportunity to thank my advisor Dr. Dereje Agonafer for giving me an opportunity to work in his projects and giving the freedom to work on my own ideas for thesis. He always asks me to dream big and do great things in life which motivated me a lot.

I would like to thank Dr. Abdolhossien Haji Sheik and Dr. Andrey Beyle for being my thesis committee members and evaluating my thesis work. I would also like to thank A S M Raufur Chowdhury, Prasanna Manohar and Ashwin Raju who helped me technically and personally. I take this chance to thank my friends who did their thesis with me for all their help in lab during the experiments. I would also like to thank all my room mates who stayed with me throughout all these two years during my masters with whom I had good times.

Finally, I would like to thank my family and especially my parents who constantly supported and motivated me in all walks of life and always fulfilled my dreams and wishes though sometimes it was beyond what they can afford at that point of time by sacrificing all their needs. Dear mom and dad no matter what I will be always with you.

ABSTRACT

ROBUST PREDICTIVE ANALYTICS FOR DETERMINING ACCLIMATION PARAMETER OF IT EQUIPMENT

Premsanth Sadasivam

The University of Texas at Arlington – USA

Advisor: Dr. DEREJE AGONAFER

Acclimation is the process in which an IT equipment adjusts to a change in its environment such as a change in temperature and humidity, allowing it to maintain performance across a range of environmental conditions. In commissioning of a new cold shipped IT equipment in data centers, environmental acclimation is an important step. Proper acclimation also minimizes the risk of powering on a machine that may still be wet due to moisture condensation. An experimental study is carried out to find how the acclimation occurs and the factors influencing it. These experiments are designed with various temperature ranges and using the data from the experiment, a method is developed to predict the ACU output temperature that should be maintained during the acclimation of IT equipment to avoid condensation. A simple machine learning model is developed and trained with the data that was collected from the experiment, this model will predict the change in temperature of the server at each instance. With the predicted temperature and the relation that has been built in this paper, an ACU output temperature is calculated. In this ACU temperature the condensation does not happen since the server temperature is always higher than the dew point temperature of our predicted ACU output temperature. So, the waiting period that is required in the normal acclimation method for the water condensed on the server to get evaporated is not needed and the equipment can be powered immediately after the server acclimates to the room temperature without any delay.

Table of Contents

Chapter 1	9
Introduction	9
1.1 Data center	9
1.2 Need for an Acclimation in an operating Data Center.....	10
1.3 Predictive analysis.....	11
1.4 Motivation and Objective	12
1.4.1 Motivation.....	12
1.4.2 Objective.....	12
1.5 Literature Review.....	13
1.6 Components of this Paper.....	16
Chapter 2	17
Experimental Work	17
2.1 Equipment used in experiments	17
2.1.1 Type-T thermocouples	28
2.1.2 Agilent DAQ	29
2.1.3 IT Servers.....	30
2.2 Experimental setup.....	19
2.2.1 Sensor calibration	20
2.2.2 Methodology and approach.....	20
2.3 Test Cases	23
2.3.1 Case 1	23
2.3.2 Case 2	24
2.3.3 Case 3	24
Chapter 3	26
Results and Discussions	26
3.1 Method to predict the acclimation temperature.....	26
3.1.1 Conventional acclimation method.....	26
3.1.2 Preparing Dataset for the Predictive Model	29
3.1.3 Developing the Predictive Model	30
3.1.4 Temperature Curve from the Predictive Model.....	31
3.2 Comparison of Normal Method and the Predictive Method.....	33
3.3 Adding predictors to the equation	35
3.3.1 Distance between the servers in the rack	35

Chapter 4	38
Conclusion and Future Work	38
4.1 Conclusion.....	38
4.2 Future works.....	39
References.....	39
Biographical Information.....	41

LIST OF ILLUSTRATIONS

Figure 1. Open compute project data center.....	9
Figure 2. Open compute project condensation	10
Figure 3. Description of the test rack showing the key drawers and components [1]	13
Figure 4. Key temperatures, relative humidity and calculated dew-points within the rack during test 1[1].....	14
Figure 5. Key system temperatures and relative humidity as the rack is acclimated from -27C to 24C (Test 2).....	14
Figure 6. THERMOTRON 7800 SE.....	17
Figure 7. THERMOTRON controller	18
Figure 8. 1U HP server.....	19
Figure 9. Thermocouples connected to the server	21
Figure 10. Experimental layout	21
Figure 11. Temperature Profile.....	22
Figure 12. Server in rack placed inside the environmental chamber	23
Figure 13. Rack with four wooden block distances in between	24
Figure 14. Server in rack covered with a shipping bag	25
Figure 15. Acclimation of server in the environmental chamber	27
Figure 16. Water condensed on the hard disk of the server during experiment	28
Figure 17. Section of data collected from the experiment.....	29
Figure 18. Predicted temperature profile.....	33
Figure 19. Temperature curve from the experiment	34
Figure 20. Temperature curve from the predictive model.....	34
Figure 21. Section of data collected from the experiment in this section	36
Figure 22. Temperature curve from the predictive model.....	38

NOMENCLATURE

P	Density (kg/m ³)
k	Thermal Conductivity (W/m-K)
C	Celsius
RH	Relative Humidity (%)
V	Voltage
DAQ	Data Acquisition
U	Rack Unit (1.75 inches)
OC	Open Compute
thrs	Time in hours
tc	Time constant
T _i	Initial Temperature
T _f	Final Temperature
Fo	Fourier number
Bi	Biot number
h	Heat transfer coefficient (W/m ² K)
L	Characteristic length
α	diffusivity
v	Volumetric Flow Rate (cfm)
IT	Information Technology

Chapter 1

Introduction

1.1 Data center

Data center is a hub for computing, processing and storage systems. The IT equipment inside a data center is associated with a power supply utilizing cables and wires. IT equipment is usually arranged on a rack and connected to the power source. Several IT equipment are inside a rack and number of racks depend on the size of the data center. Due to the operation of the IT equipment expansive measure of heat is created from it, and this heat produced may build the temperature of a Data Center. Data Centers cannot work at high temperatures; this might disrupt the function of IT equipment. To cool the Data center and to expel the hot air, a cooling method is chosen. Cooling the data center evacuates the heat as well as enhances the effectiveness of the data center. Design considerations are to be followed before building a data center, [5]

- Design Programming – Space Planning, Type of cooling and power source is chosen, Technology infrastructure design.
- Modeling Criteria – To find various parameters such as, number of Equipment, size, location, topology, IT floor layouts, power and cooling technology.
- Design Recommendations – PUE (power utilization efficiency), cooling capacities and power required and mechanical and electrical facilities.
- Environmental control – Air conditioning used to control the temperature and humidity of the room.

- Global Risk Issues – Given the current and more catastrophic climate related occasions affecting even more profoundly developed areas, we all need to survey and maybe re-assess our essential assumptions.

Even though there are numerous elements to be considered while planning a data center, these are the most critical elements one must consider before outlining a data center.



Fig 1: Open compute project data center [7]

1.2 Need for an Acclimation in an operating Data Center

The demand for high data center capacity in the US grew tremendously in the most recent five years because of the high computational power required by industry. Production of IT equipment has increased in recent years due to the high demand. These equipment, once manufactured, are dispatched to the data centers in different weather conditions. Computing equipment are designed to operate in a specific condition, but some extreme condition shipping leaves the equipment well

outside their designed operating condition. However, systems are often shipped in conditions that leave them well outside the operating specifications on delivery at the destination datacenter. This issue is particularly critical in cold weather shipping where a computing system can reach the destination well below the destination data center dew point, resulting in moisture in the air condensing on the cold surfaces.



Fig 2: Open compute project [7]

This IT equipment are allowed to acclimate such that the temperature of the equipment reaches the dew point of the data center after which it should be safe to switch on the device.

1.3 Predictive analysis

Predictive analytics is an area of statistics that deals with extracting information from data and using it to predict trends and behavior patterns. Often the unknown event of interest is in the future, but predictive analytics can be applied to any type of unknown whether it be in the past, present or future. The core of predictive analytics relies on capturing relationships between explanatory variables and the predicted variables from past occurrences and exploiting them to predict the unknown outcome. It is important to

note, however, that the accuracy and usability of results will depend greatly on the level of data analysis and the quality of assumptions.

Predictive models are models of the relation between the specific performance of a unit in a sample and one or more known attributes or features of the unit. The objective of the model is to assess the likelihood that a similar unit in a different sample will exhibit the specific performance. The available sample units with known attributes and known performances is referred to as the "training sample". The units in other samples, with known attributes but unknown performances, are referred to as "out of [training] sample" units. The out of sample units do not necessarily bear a chronological relation to the training sample units. Regression models are the mainstay of predictive analytics. The focus lies on establishing a mathematical equation as a model to represent the interactions between the different variables in consideration. Depending on the situation, there are a wide variety of models that can be applied while performing predictive analytics. Some of them are briefly discussed below. [4]

1.4 Motivation and Objective

1.4.1 Motivation

To develop a solution to the failure caused due to improper acclimation is the main motivation behind this paper. Waiting too little might damage the system while waiting a long time might cause loss of computational time. To find a method that can prevent the condensation of moisture on the server during acclimation is an important step.

1.4.2 Objective

There are two main objectives to this paper.

1. To identify how each factor influences the acclimation.
2. To develop a method using predictive analytics that prevents the condensation of moisture on the server during the acclimation process.

1.5 Literature Review

The most important paper in acclimation of new IT equipment is by Milnes et.al. That paper is summarized as below:

Through experiments and modeling, the factors that impacts the acclimation is studied on the rack level as shown below.

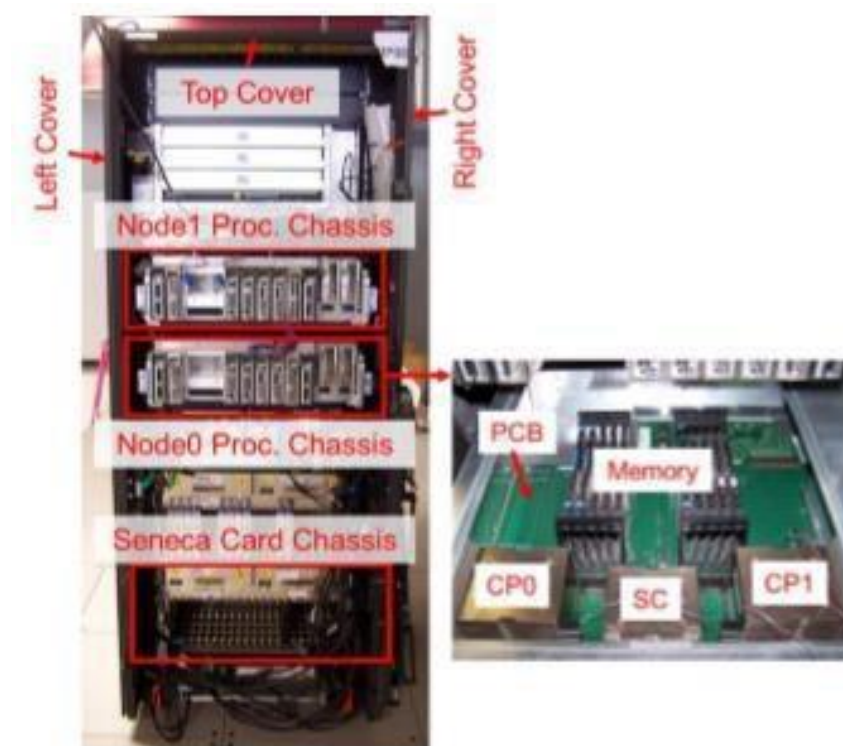

Fig 3: Description of the test rack showing the key drawers and components [1]

Two experimental conditions using environmental chamber:

- 1) Test 1: -27C and 30% RH to 35 C and 85% RH, temperature and humidity conditions monitored as system acclimated for 48 hours.
- 2) Test 2: -27C and 30% RH to 24C and 54% RH, temperature and humidity conditions monitored for 49 hours, plastic packaging removed 25 hours into the experiment.

Acclimation modelling was done to understand the impact of factors like mass, shipping bag removal, and destination conditions on the acclimation time.

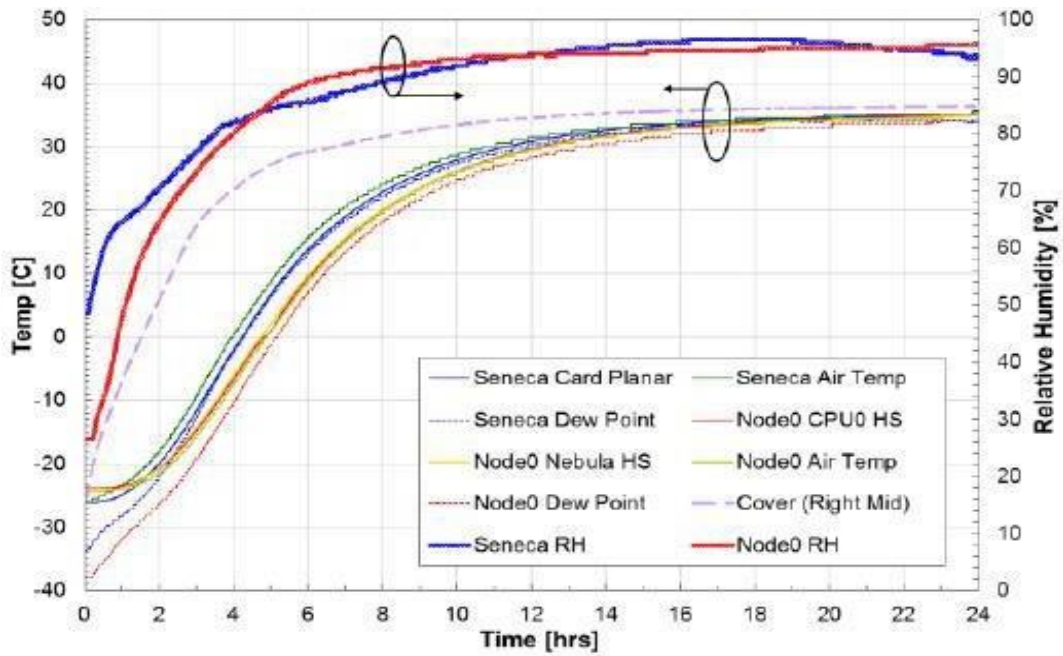

Fig 4: Key temperatures, relative humidity and calculated dew-points within the rack during test1[1]

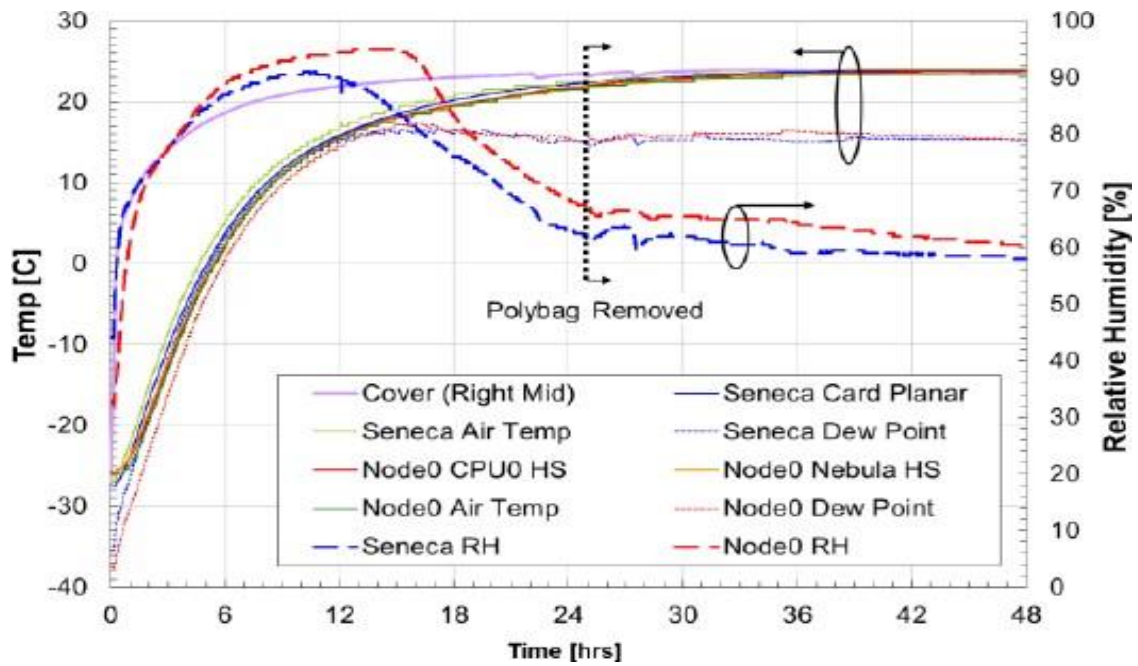

Fig 5: Key system temperatures and relative humidity as the rack is acclimated from -27C to 24C

(Test 2) [1]

Table1. Summary of modeling results from study of impact of destination environmental conditions [1]

Recommended	Temp. C	18	23	27
	% RH	60	60	45
	Time w/ bag	14	14	12
	Time w/o bag	53	39	26
A1	Temp. C	15	20	32
	% RH	80	80	40
	Time w/ bag	19	19	11
	Time w/o bag	72+	72+	20
A2	Temp. C	10	25	35
	% RH	80	80	45
	Time w/ bag	19	20	12
	Time w/o bag	72+	51	18

Results from the reviewed paper.

- It is understood from the paper that the main source of moisture was the forced air circulation during the heating process.
- Visually inspecting the inside and outside of the machine is advised.
- If a lumped capacitance model is assumed, then the cover has less time constant while the other components have more time constant.

1.6 Components of this Paper

There are two main components of this work:

1) Experimental.

- To study how different temperature pattern affects the condensation during the acclimation.
- various factors that affects the acclimation.

2) Prediction analytics.

- A machine learning model is trained with the data that is obtained from the experiment.
- A method is developed to predict the ACU temperature that should be maintained at each instance so that the dew point temperature will be always lower than the server temperature.

Chapter 2

Experimental Work

2.1 Equipment used in experiments

- Environmental chamber (THERMOTRON 7800 SE)

This equipment is very needed for the experimental work should be able to simulate the shipping condition and the destination conditions. The environmental chamber by Thermotron was able to fulfill that requirement. This machine had the following specification. [7]

- ✓ Temperature Range: (-70°C to +180°C)
- ✓ Relative Humidity Range: (10% to 98% Rh)
- ✓ Ramp rates: (5°C/min - 25°C/min)
- ✓ Workspace volume: 2.7 cubic feet (586L)

This Environmental chamber was suitable for the experiments since all the scopes were within the scope of the machine.



Fig 6. THERMOTRON 7800 SE

This environmental chamber is attached with a controller where the temperature and humidity can be setup as it is required per the experiment.

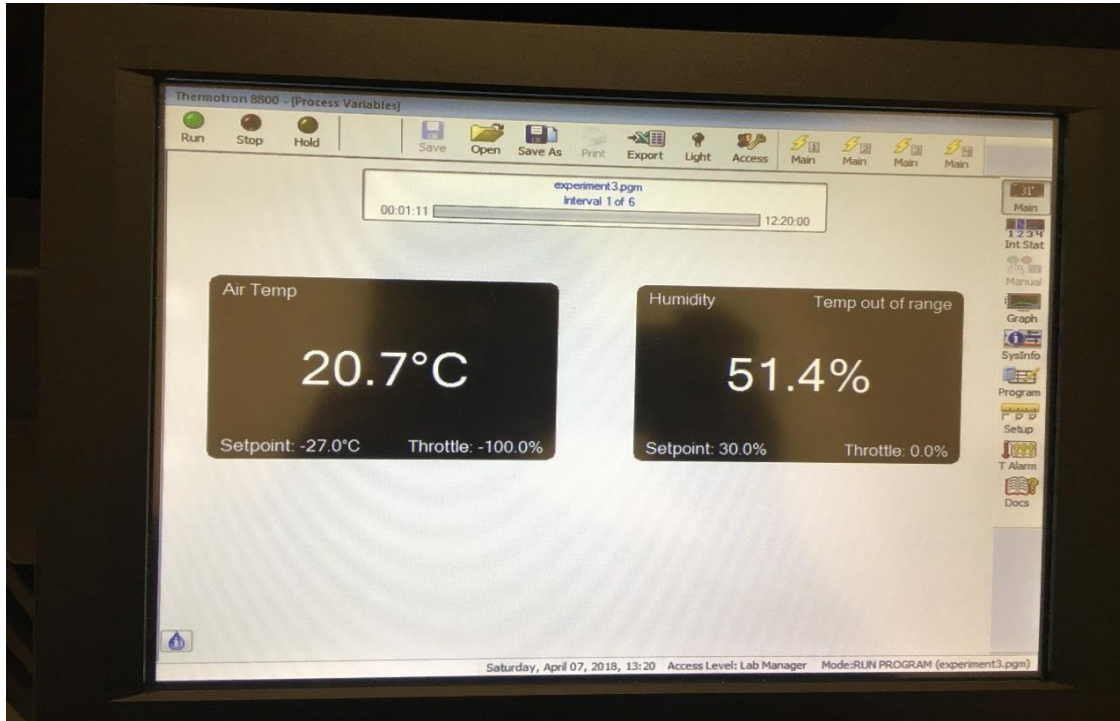

Fig 7. THERMOTRON controller.

2.1.1 Type-T thermocouples

A thermocouple is an electrical device consisting of two dissimilar electrical conductors forming electrical junctions at differing temperatures. A thermocouple produces a temperature-dependent voltage because of the thermoelectric effect, and this voltage can be interpreted to measure temperature. Thermocouples are a widely used type of temperature sensor. [6]

2.1.2 Agilent DAQ

A DAQ from Agilent is used to read the temperature from the thermocouple that are kept in the various spots of the server. Thermocouples are first connected to the multiplexer and then

it is read by the computer through the DAQ via USB. The temperature from the experiment is well within the scope of the T type thermocouple.

2.1.3 IT Servers

For the study of this project, 1 U HP servers is used to test how the acclimation is influenced by different parameters. These servers are arranged in racks using a wooden block to imitate the racks setup. By varying the number of wooden blocks, the distance between servers in the rack is established.



Fig 8: 1U HP server

2.2 Experimental setup

First experimental run was a dry run during which the environmental chamber was operated at different temperature and check the consistency of the sensor readings. Next sequences of the

experiment are the real experiments where the parameters are set in such a way that it should be able to explain the influence of different factors. And, experiments are designed in such a way that it shows the difference between the time taken for the acclimation of different server arrangements.

2.2.1 Sensor calibration

To understand how precise and correct the sensor, an initial dry run is carried out in which the chamber is set at a low temperature of about -24C and varied till 45C. This range is selected for calibration because the temperature for our experiment lies in between these two bounds. Many temperature points are set in between -24C and 45C and allowed it to stay fixed in that temperature for one hour and during this course of time the temperature is read from all 20 sensors will have for the experiment. It was found from the experiment that the accuracy of the sensor was in the range of +/- 1C to +/- 1.5.

2.2.2 Methodology and approach

As Discussed earlier a 1U Hp server is used and the T- type thermocouple is attached to five different components of the server, they are namely Hard disk, RAM, Fan, Heat sink and the chassis.

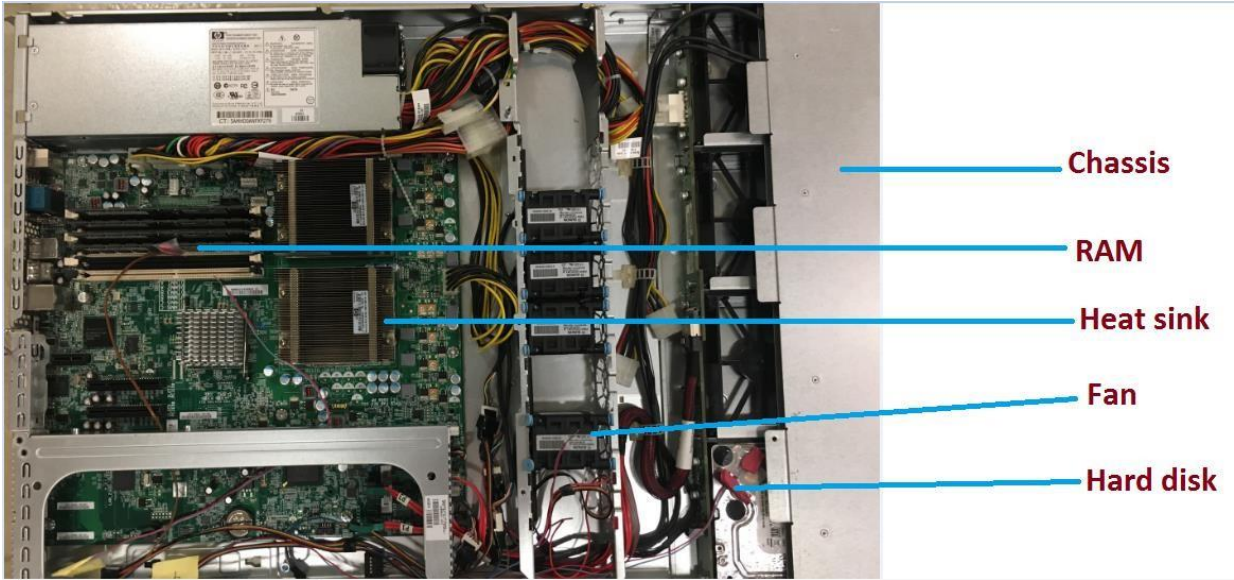

Fig 9: Thermocouples connected to the server.

Schematic representation of the experimental setup is give below, the setup is divided into three different units namely the environmental chamber, DAQ and the computer.

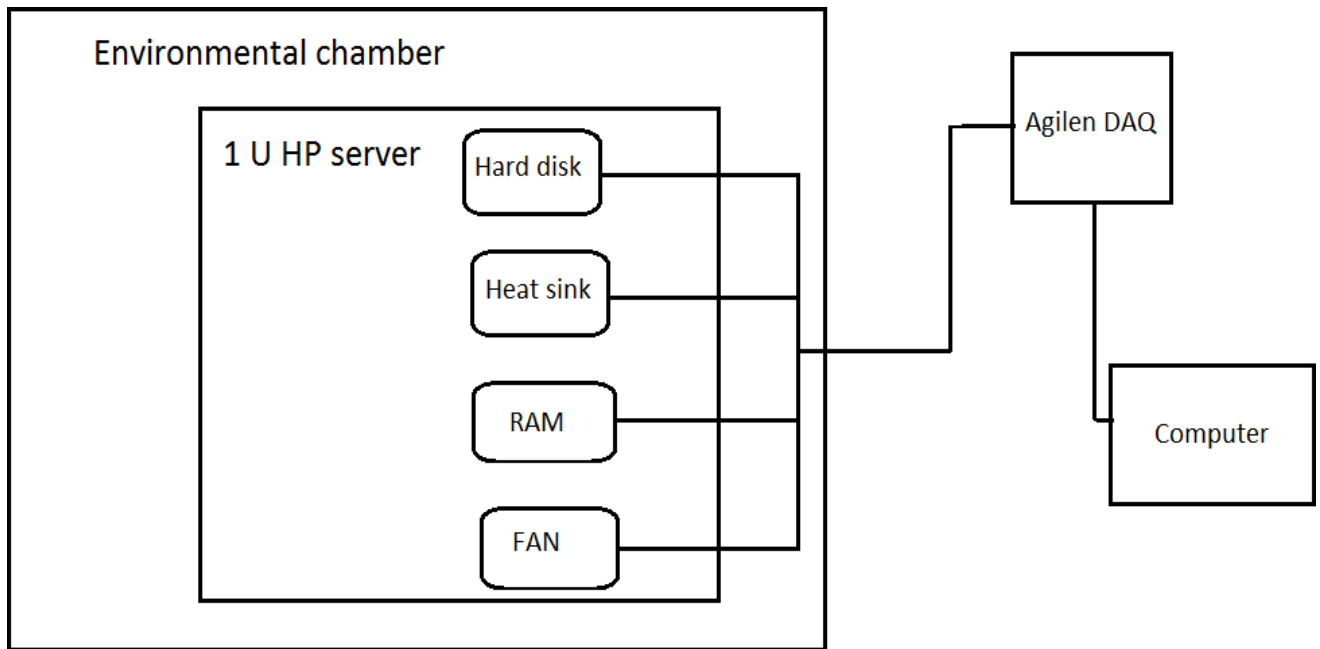

Fig 10: Experimental layout.

The shipping and destination condition used in all the tests below were taken based on the temperature assumed in the previous study by Dr. Milnes. As shown in Fig 10 the thermocouples are first connected to the components in the server and then the other end is connected to the multiplexer through a DAQ and then it is connected to the computer from where the data is extracted and stored in the hard disk. The server is first cooled to -27°C where it was kept for 4 hours to make sure that all components inside the server in the rack reaches the initial condition of -27°C , after which the chamber is set to 35°C with a ramp rate of 10 minutes, where it is again kept for almost 4 hours to study the time taken for all components to reach the final condition of 30°C .

The temperature profile set in the environmental chamber is shown below. The experiment is run for approximately 18 hours, so there is enough time for all the components to acclimate.

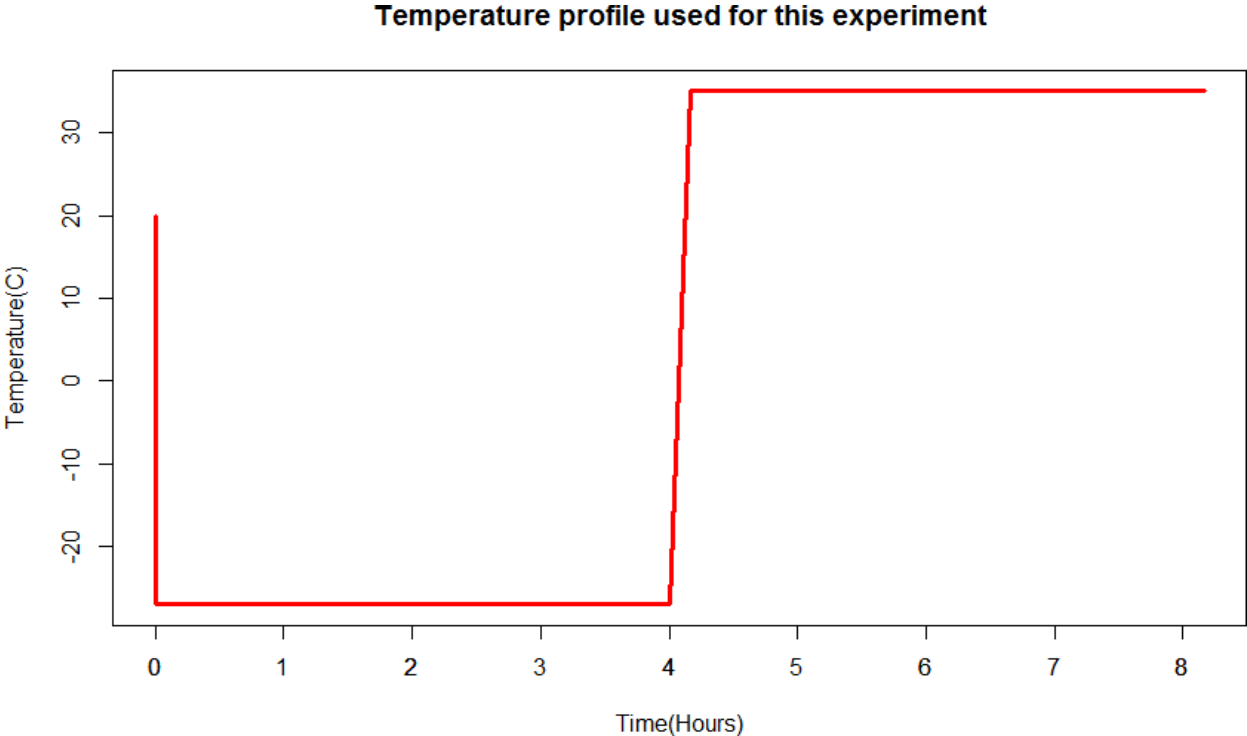

Fig 11: Temperature Profile



Fig 12: Server in rack placed inside the environmental chamber.

2.3 Test Cases

2.3.1 Case 1

In these test cases experiment was done with the same server but with different setup that we assume which might possibly affect the acclimation. To simulate the extreme shipping condition of -27C and the destination condition of 35C which is well outside the ASHARE condition but can be used to get the results for extreme condition. Now the distance between the server was reduced by constantly removing one wooden block in between from each server. Initially there were four blocks in between each server in the rack and it is reduced to one block in between each server which means the experiment is ran with three different distance in between each server.

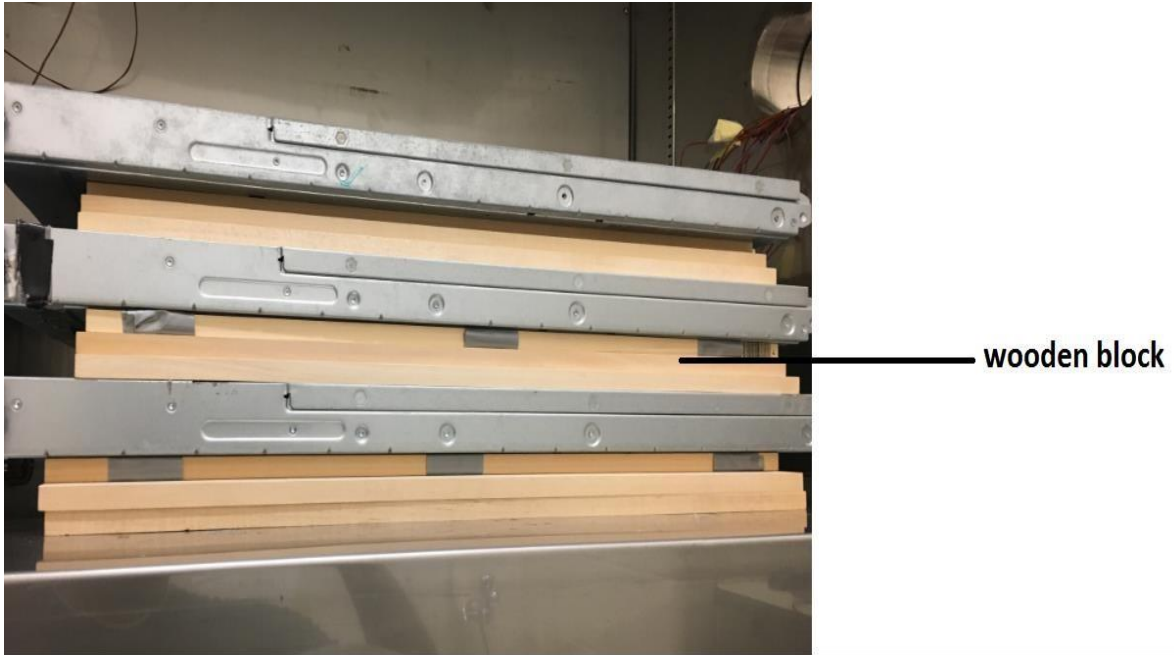

Fig 13: Rack with four wooden block distances in between.

2.3.2 Case 2

This experiment is designed to find how the number of servers in a rack affects the acclimation. So initially the experiment was running with three servers, whereas the temperature of those five components of the second server from the bottom is recorded. The same temperature profile from Fig 11 is followed here, that is -27°C for four hours and increased to 35°C with the ramp rate of 10 minutes and maintained at 35°C for four hours. The same experiment ran by using four and five servers each in the rack, maintaining the same distance between the servers. In all three runs the temperature data of only the second server from the bottom is considered. So that the difference in acclimation with respect to the number of servers can be captured because except the number of servers, other conditions are constant for all three experiments.

2.3.3 Case 3

To find how the acclimation is affected if the servers allowed to acclimate along with shipping bag. so, in this run the servers are covered in rack using a shipping bag. The rack consists of four

servers with one wooden block distance between the servers. Same temperature profile used in the previous experiment is followed here, that is -27°C for four hours and increased to 35°C with the ramp rate of 10 minutes and maintained at 35°C for four hours. Even though the rack is completely covered there is a small opening at one corner for all the sensor wires that is connected to the computer, so it might affect the results but since it is a small opening it is neglected.



Fig 14: Server in rack covered with a shipping bag.

Chapter 3

Results and Discussions

3.1 Method to predict the acclimation temperature

Focus of this project is to find a method by analyzing the data that we got from the experiment. First let us consider the data that is extracted from our experiment, and the temperature is considered only from the point where the temperature is raised from -23C to the room temperature since our core intention is to develop a method to predict the ACU output temperature curve for which the condensation does not occur on the server. We ignore all the data regarding how the server reaches the cold temperature and we consider only the temperature data that is recorded during the acclimation of server from the cold temperature to the room temperature in this data analytics.

3.1.1 Conventional acclimation method

First let us visualize the data to see how the servers acclimated to the room temperature in the normal method. We consider the initial condition of the rack to be around -23C which is like the condition of the cold shipped server that is ready to be moved from the truck to the final condition of 20C and 40% RH with which the data center is maintained. All the components of the servers in rack we concern about in this paper reached the temperature around -23C. The Fig 15 shows the temperature pattern of the acclimation of server from the experiment we performed in the environmental chamber.

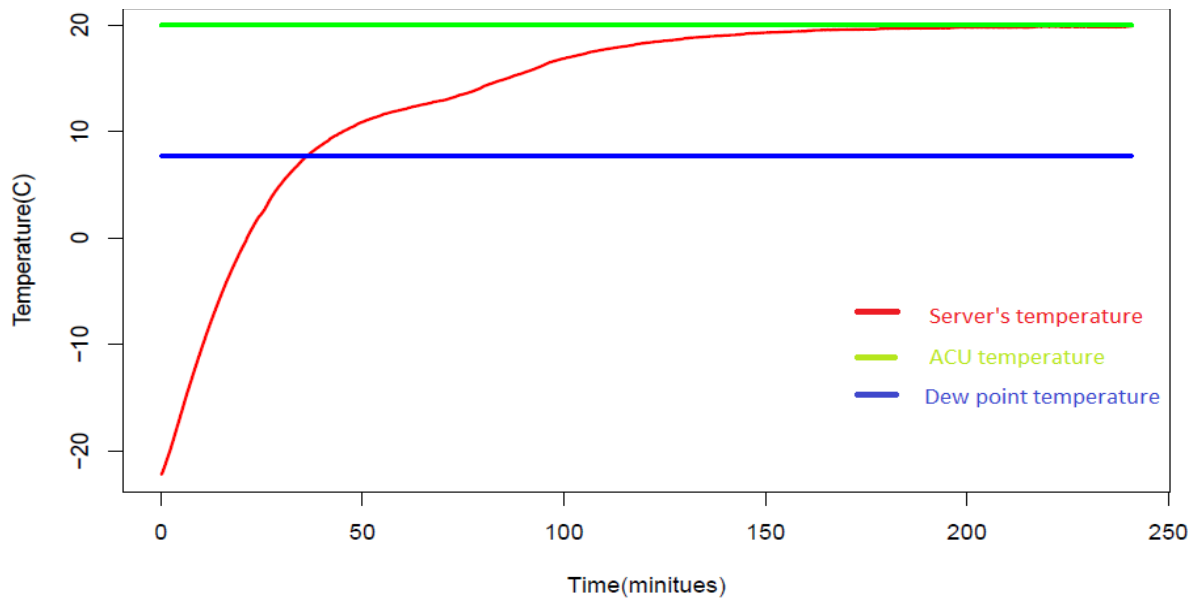

Fig 15: Acclimation of server in the environmental chamber.

At time = 0, the temperature of the server is -23C and the ACU temperature is set to 20C since that is the room temperature we want the server to reach. At this stage the dew point temperature of the 20C and 40%RH air that comes out of ACU is 6C. If this ACU air hits any object that is less than 6C it gets cooled and the moisture in the air condense on the object. In our case the server is at -23C which is way lower than the dew point, so it cools that air and the air gets condensed, so the moisture that condenses will form a layer of water over the surface of the server as well as the internal components of the server.

Fig 15 shows this phenomenon, the blue line in the plot is dew point temperature, red line is the server temperature and the green line is the temperature of the air that comes out of ACU. It is clearly seen in the plot that for around first 40 minutes the server temperature (red line) line is lower than the dew point temperature (blue line), during this time condensation happens. After 40 minutes, server temperature increase and reaches the temperature more than the dew point

temperature so the condensation stops from there and the acclimation continues. it takes 250 minutes totally for the server in rack to reach the set temperature of 20C.

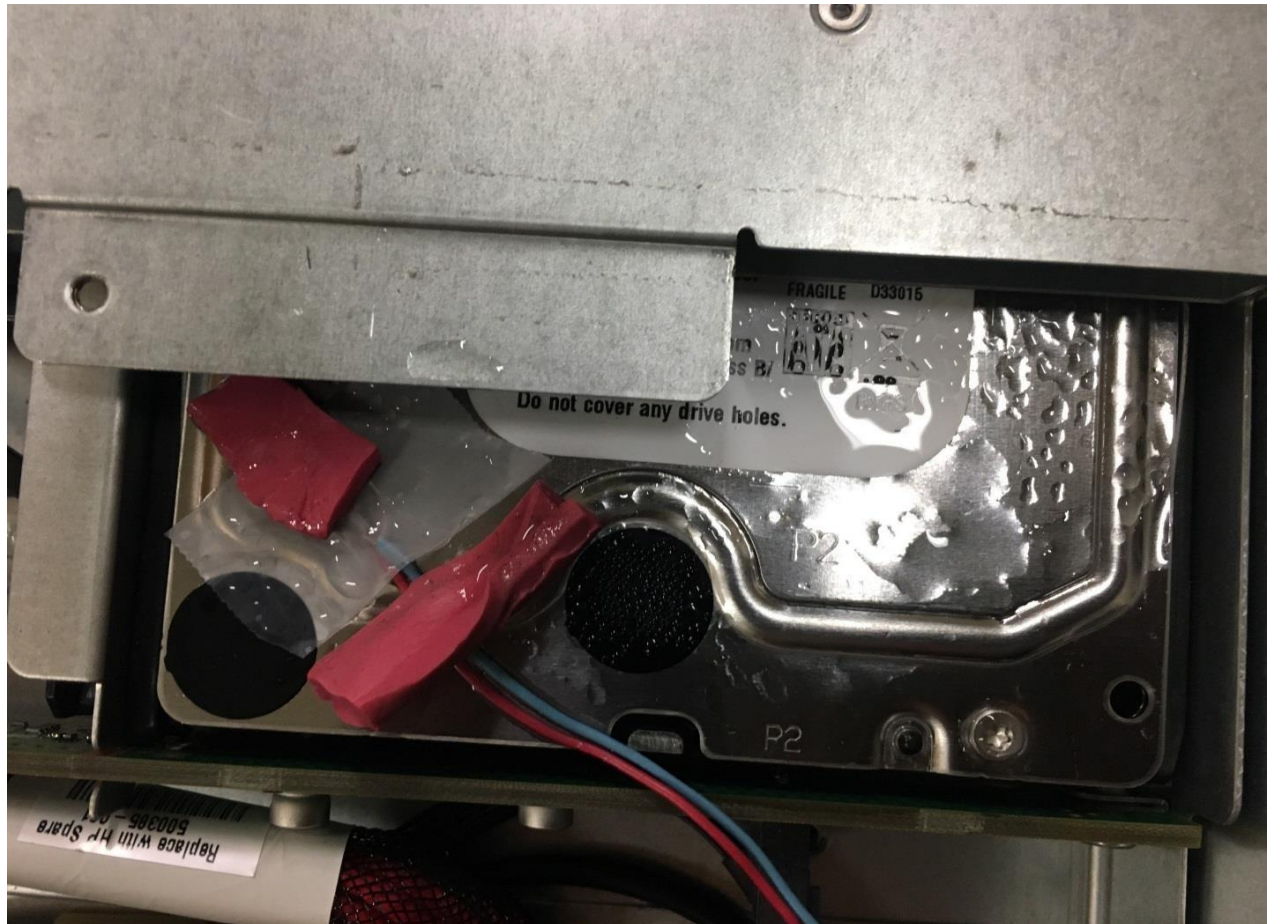

Fig 16: Water condensed on the hard disk of the server during experiment.

The Fig 16 show the water that was condensed in the environmental chamber during first 40 minutes, even though the server rack reaches the set temperature of 20C in 250 minutes, normally the water that condensed on the server surface and in its component takes at least 48 hours to get completely dried. If the server is connected to the power supply before it gets dried it will experience an electric short circuit and the water might also leads to small metal corrosion. So, we should wait until it gets dried completely to avoid these problems. During this time the data center wastes its computational power since it is kept powered off.

3.1.2 Preparing Dataset for the Predictive Model

Now if there is a method by which we can predict the temperature of the server at each instance and maintain the dew point temperature of the ACU always lower than the server's temperature and along with taking the temperature to as maximum as possible to rapidly raise the server's temperature to the set temperature. From the experiment conducted at the previous section we collected different datasets. In one dataset, at every 10 seconds we collected the ACU temperature and Server temperature.

Scan	Time	Elapsed	Ac_temp	Previous	Hard_disk
1082	4/2/2018 22:24	00:03:00:0	-26.2167	-25.973	-25.973
1083	4/2/2018 22:24	00:03:00:1	-25.4333	-25.973	-26.009
1084	4/2/2018 22:24	00:03:00:2	-24.65	-26.009	-25.977
1085	4/2/2018 22:25	00:03:00:3	-23.8667	-25.977	-25.984
1086	4/2/2018 22:25	00:03:00:4	-23.0833	-25.984	-25.98
1087	4/2/2018 22:25	00:03:00:5	-22.3	-25.98	-25.973
1088	4/2/2018 22:25	00:03:01:0	-21.5167	-25.973	-25.98
1089	4/2/2018 22:25	00:03:01:1	-20.7333	-25.98	-25.98
1090	4/2/2018 22:25	00:03:01:2	-19.95	-25.98	-25.984

Fig 17: Section of data collected from the experiment.

Fig 17 shows the structure of the data set that is collected from the experiment. There are 2588 rows in that dataset. The first column is "Scan" which tells the number of scan the sensor has completed from the starting of the experiment, second column "Time" gives the clock time at which the temperature is recorded, the third column "Elapsed" tells the total time into the experiment at the instance when each temperature is recorded, fourth column "Ac_temp" is the

temperature of the air that comes out of the ACU at that instance, fifth column “Previous” gives the temperature of the previous scan that is 10 seconds earlier at that time, “Hard_disk” gives the temperature of the server at that instance.

3.1.3 Developing the Predictive Model

Using the dataset in the previous section a predictive model is developed using the “R” software package. Since it is an open source software we can use all the functionality of the software without any restrictions. A machine learning package available in “R” known as “nls” is used to train the model. “nls” uses a predefined algorithm to train the model. The data set is randomly divided in to 75% of rows in to Train dataset and 25% of rows in to test dataset. A simple linear model is developed with the base equation $\mathbf{aX1+bX2 = Y}$.

whereas the,

X1 – ACU temperature.

X2 – Server temperature.

Y – Predicted server temperature (After 10 secs).

a, b – Weights.

Using this equation and the training dataset the machine learning model is trained. After the model is trained the weights are found to be,

a = 0.004156.

b = 0.995977.

So, the equation will be $\mathbf{0.004156*X1 + 0.995977*X2 = Y}$, now this equation is tested with the 25% of data set which we separated as the test data that is not used for the training to find the

accuracy. The accuracy of the machine learning model we created is **98.69%**. Now this equation can be used to find the server temperature that is the temperature of the server at any instance is given by the ACU output air temperature and the temperature of the server 10 seconds earlier which is X1 and X2 in the equation.

3.1.4 Temperature Curve from the Predictive Model

Now for the same condition that is mentioned in 3.1.1 where the server initial temperature is - 22C, relative humidity 40%. If the ACU dewpoint temperature is lower than the server temperature condensation does not happen. So, the dewpoint temperature should be at least -23C. With a relationship equation using any two of three in dry bulb temperature, relative humidity and dewpoint temperature can be used to find the third parameter. The equation is given by [2]

$$\mathbf{Temp} = 243.04 * (((17.625 * \mathbf{dp}) / (243.04 + \mathbf{dp})) - \log(\mathbf{rh}/100)) / (17.625 + \log(\mathbf{rh}/100) - ((17.625 * \mathbf{dp}) / (243.04 + \mathbf{dp})))$$

Temp – ACU temperature.

dp – dew point temperature.

rh – Relative humidity.

In the above-mentioned equation, the dew point temperature -23C and RH of 40% is plugged in to find the required ACU1(Air conditioning air temperature at time step 1) temperature. Now that ACU1 temperature and server temperature T1(at time step 1) is plugged in to the machine learning model to find the change in server temperature which is T2. Now using T2 as the server temperature the same calculation is done to find the ACU2 temperature and using that the T3 is predicted and the loop goes on like this until the server temperature reaches the set temperature. In this case it is till 20C.

We can keep on increasing the temperature of the air that comes out of ACU even above the set temperature if its dew point is not above the server temperature. Doing so is not so particle in the normal method since we do not have a method to predict server temperature at each instance.

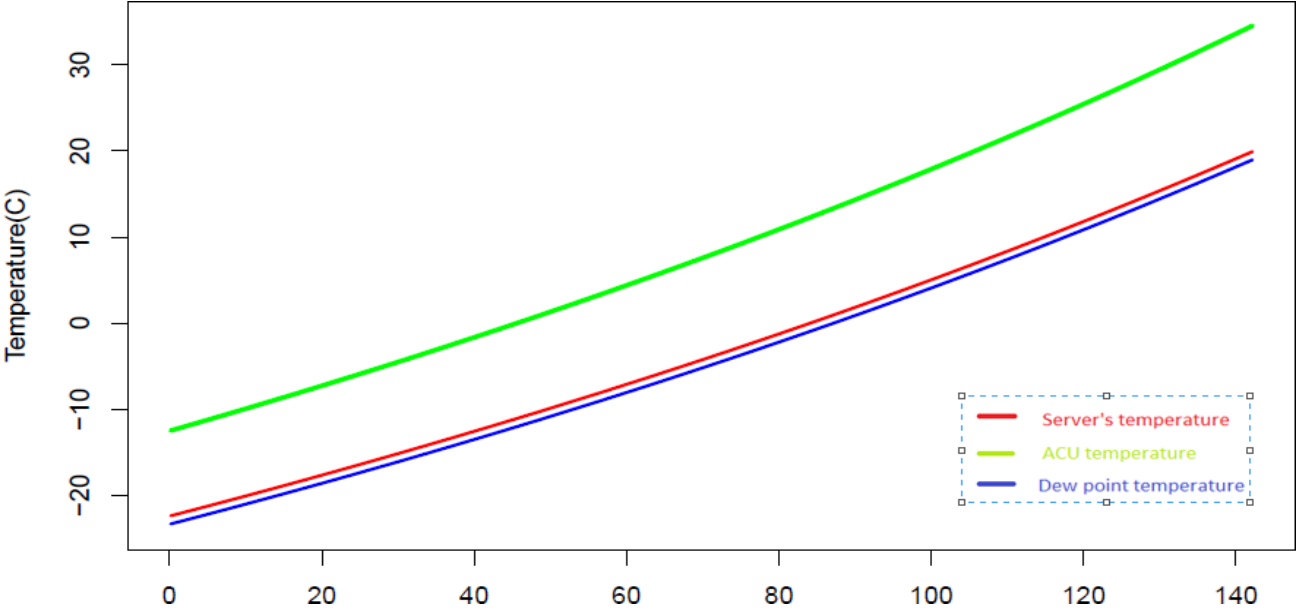

Fig 18: Predicted temperature profile.

Fig 18 shows that after around 100 minutes the temperature of ACU is increase more than the set temperature 20C, it is safe to raise the temperature from that instance since the server has reached the temperature that is more than the dew point of dry bulb temperature 20C and rh 40%.

3.2 Comparison of Normal Method and the Predictive Method

Now the difference between normal method and the predictive method is compared to understand where the predictive method differs from the normal conventional method.

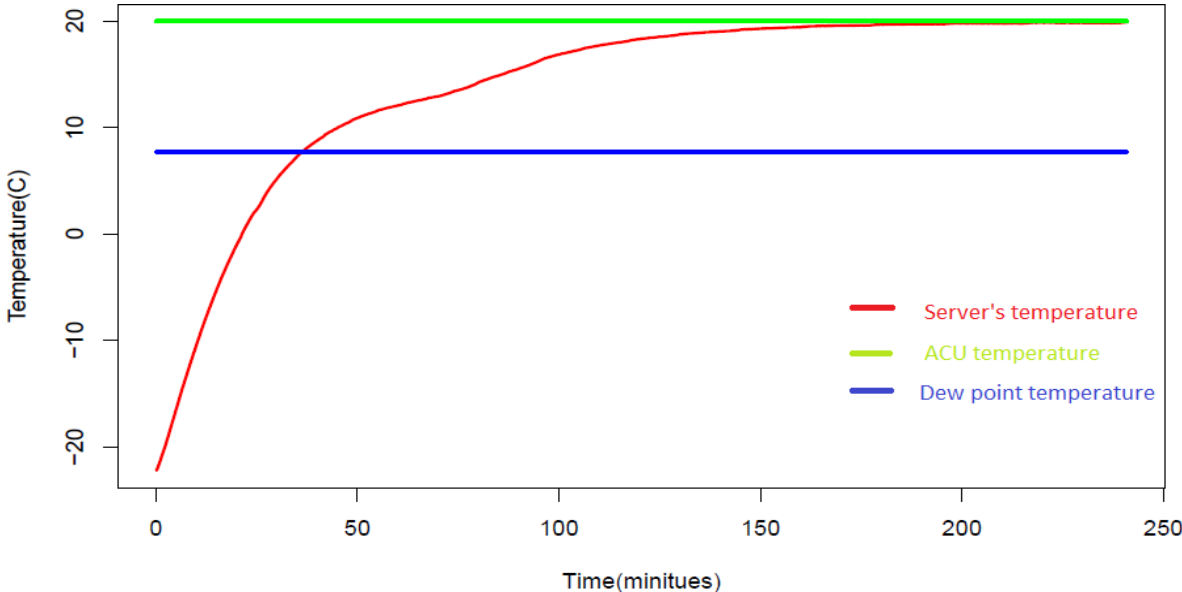

Fig 19: Temperature curve from the experiment.

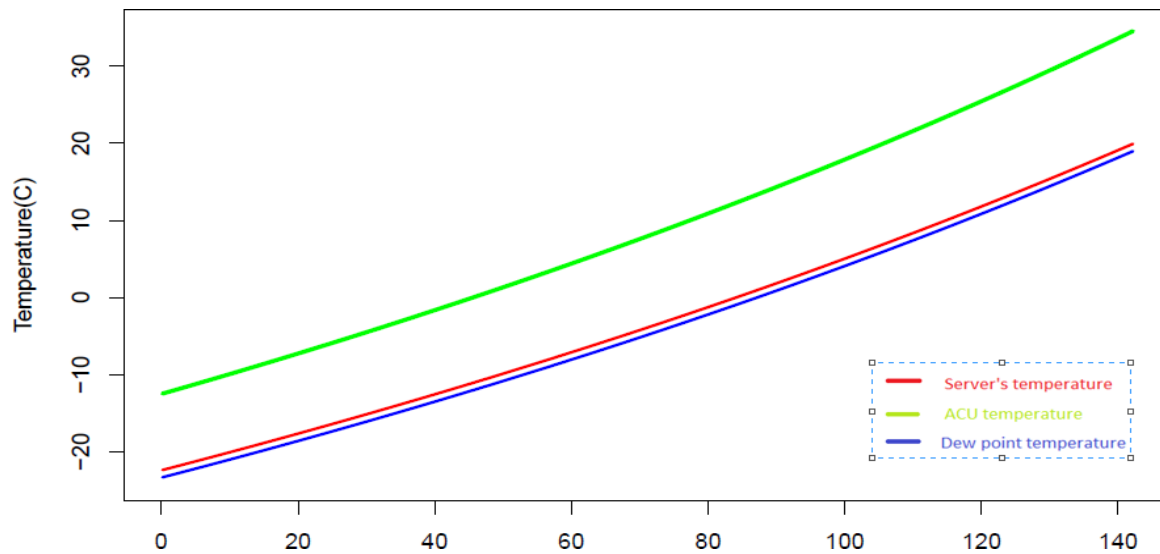

Fig 20: Temperature curve from the predictive model.

Both the temperature curve plots have initial temperature, final set temperature and the relative humidity as same. Only the acclimation method is different.

The main difference between the two method is that in the predictive model, dew point line is always lower than the server's temperature line. That implies that the server temperature is always maintained higher than the dew point temperature which means the condensation never happens throughout the acclimation. And the other important outcome of the predictive method is that the total time for acclimation is just 140 minutes (Fig 20) where as for the conventional method take around 250 minutes (Fig 19). This is because the ACU output temperature is increased beyond the set temperature when the server temperature is raises beyond the dew point temperature of the set point temperature. In our case it happens around 100 minutes. This is the main factor that is the reason for this method to take lesser time for acclimation than the normal method.

3.3 Adding predictors to the equation

The model which we developed in the section 3.2.4 is trained with the two predictors namely ACU output temperature and the previous step server temperature. The predictors of this method should be changed before using it to the real time cases. This model can be used as it is only if the data center is exactly same as our experimental setup but in real time, parameters like type of cooling, distance between the cooling vent and the server, shipping bag, number of servers etc. Since our training data set has the server initial temperature from which it should be acclimated, we can vary the server initial temperature and humidity.

So, to create an ultimate model that can be used for any data center at any condition, all different condition should be included in the model as a predictor. The model in this paper have only two predictors which is X1 and X2, but if an ultimate model is created then it will include at least 40 predictors. In this paper to add other predictors few experiments were ran and the data set have been collected to create a prediction model with those predictors. The predictors that are intended to be added are shipping bag, number of servers in a rack and distance between the servers.

3.3.1 Distance between the servers in the rack

The data set is obtained from the experiment by varying the number of servers in the rack as mentioned in the case 1 from the section 2.3. The structure of the data set collected from the experiment looks like Fig 21.

Scan	Ac_temp	Previous_	hard_disk	distance
1	-27	26.515	26.511	3
2	-27	26.511	26.49	3
3	-27	26.49	26.471	3
4	-27	26.471	26.421	3
5	-27	26.421	26.378	3
6	-27	26.378	26.282	3
7	-27	26.282	26.189	3
8	-27	26.189	26.071	3

Fig 21: Section of data collected from the experiment in this section.

There are around 8000 rows in that dataset. Records from all three experiments are shuffled to make the model more robust. Then column is “Ac_temp” which tells about the temperature of the air that comes out of the air cooling unit at the instance, “Previous” gives information about the temperature of the server 10 seconds earlier, “distance” tells about the distance between the server, in this case it will either 1,2 or 3, “hard_disk” is the temperature of the server after 10 seconds. A machine learning model with the base equation $aX_1 + bX_2 + c(X_3^2) = Y$ is trained as discussed in the 3.2.3 with this dataset.

$$aX_1 + bX_2 + c(X_3^2) = Y.$$

X1 – ACU temperature.

X2 – Server temperature.

X3 – distance between server.

Y – Predicted server temperature,

(after 10 sec).

a, b, c – Weights.

After training the model the weights are found to be $\mathbf{a} = 5.767\text{e-}03$,

$\mathbf{b} = 9.943\text{e-}01$, $\mathbf{c} = 6.771\text{e-}05$. So now the trained model will be

$5.767\text{e-}03 \cdot X_1 + 9.943\text{e-}01 \cdot X_2 + 6.771\text{e-}05 \cdot (X_3^2) = Y$. So, the temperature curve of the air that comes out of ACU is predicted using this equation by using the loop that is discussed in the section 3.2.4.

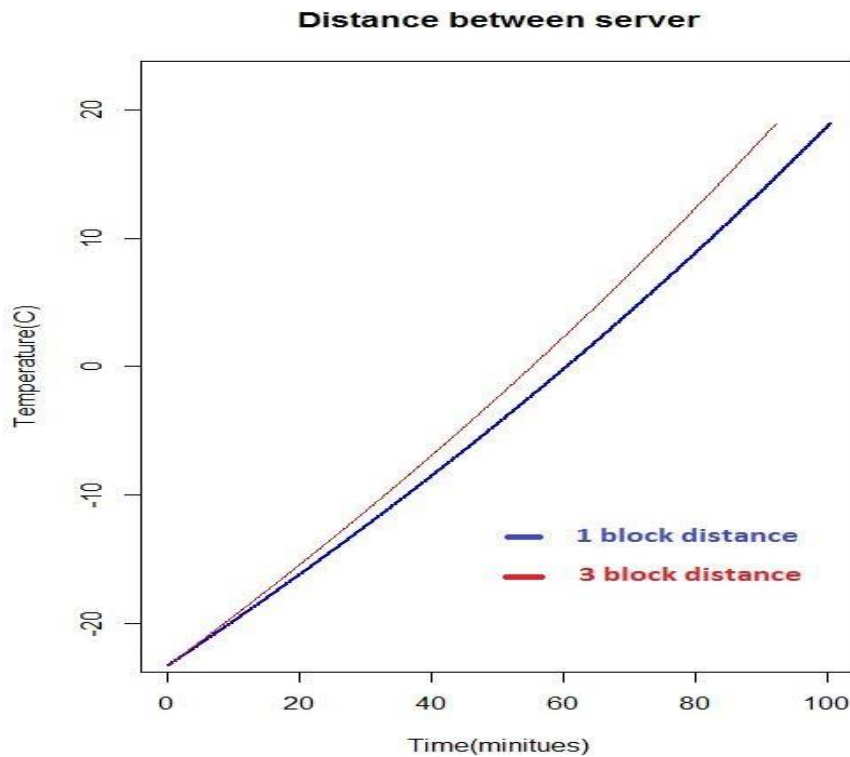

Fig 22: Temperature curve from the predictive model.

The Fig 22 shows the predicted temperature curve using the model that is trained by the dataset obtained from the experiment described in this section. There is edge gap between the time taken for the three wooded block and the one wooden block distance. Both the temperature line presented in this plot will not create any condensation since it is predicted based on the method we developed in section 3.2.4.

Chapter 4

Conclusion and Future Work

4.1 Conclusion

In all, there were two sections in this paper, first being the experiment for acclimation and extracting the data from the experiment. We obtained all data for five different components of the server which was mentioned clearly in the previous sections, they are Hard disk, Heat sink, RAM, Fan, cover and all these components were assumed to be lumped mass. We used the same type of servers throughout all these experiments which is a 1U Hp server. Second part of this experiment is to analyze the data that is extracted from the experiment and find the patterns and then use the dataset to train a machine learning model that fits the data to the most. By using that model to predict the air that comes out of ACU and running a loop to generate the temperature data until the server reaches the set temperature an ACU temperature profile is predicated for which the condensation of moisture in air does not happen throughout the acclimation. In this paper the model with two predictors is explained and tested in detail but in real time the model should be with as many factors that might affect the acclimation. Server manufactures can perform a wide range of experiment by changing all the factors that affects the acclimation to obtain the dataset and develop an ultimate model based on the method discussed in this paper that includes as many predictors that can be included which have influence over the acclimation so that the prediction of the temperature curve that will not create condensation will be so accurate.

4.2 Future works

The future work should concentrate more on finding other predictors that influences the acclimation using the dataset extracted from conducting experiments with different conditions. Training the machine learning model with high output accuracy by using efficient function and coding should be done in the future. Comparing the predicted results with the data extracted from the commissioning of new modular data center can also be done to improve the method.

References

- [1] "David, Milnes P., et al. "Environmental acclimation of computing systems." Thermal and Thermomechanical Phenomena in Electronic Systems (ITherm), 2016 15th IEEE Intersociety Conference on. IEEE, 2016.
- [2] "Dew Point Calculator," Image permanence institute. [Online]. Available: <http://www.dpcalc.org>. [Accessed: 2018]
- [3] "Heisler Chart" ch05_supp_heisler. [Online]. Available: http://homepages.wmich.edu/~leehs/ME431/ch05_supp_heisler.pdf. [Accessed: 2017]
- [4] "Waller, M. A., & Fawcett, S. E. (2013). Data science, predictive analytics, and big data: a revolution that will transform supply chain design and management. *Journal of Business Logistics*
- [5] "Data center design consideration," ASHRAE. <https://www.ashrae.com/>
- [6] "Wikipedia," Thermocouple. <https://en.wikipedia.org/wiki/Thermocouple>
- [7] "Open compute," Open compute project <http://www.opencompute.org>

Biographical Information

Premasanth Sadasivam (Feb 22nd, 1993) is from Dharmapuri, Tamilnadu, India. He completed his bachelors from Anna university in May 2014. Prem then worked as Software engineer for two years at Accenture Pvt Ltd. He was admitted to the University of Texas at Arlington in fall 2016 for Master of Science in Mechanical Engineering. He joined EMNSPC team in spring 2017 and worked on various projects.

His primary research includes areas related to data center acclimation and free cooling in an operating data center. Premasanth Sadasivam graduated from the University of Texas at Arlington on May 12th, 2018. For further reference you can email me at premasanthzone@gmail.com or call me at +1 (214)-609-4521.