

A REVISED PHONOLOGY OF KABIYE SEGMENTS AND TONES

by

CECILE MAMALINANI PADAYODI

Presented to the Faculty of the Graduate School of
The University of Texas at Arlington in Partial Fulfillment
of the Requirements
for the Degree of

DOCTOR OF PHILOSOPHY

THE UNIVERSITY OF TEXAS AT ARLINGTON

August 2010

Copyright © by Cécile M. Padayodi 2010

All Rights Reserved

DEDICATION

To you, the ‘human angels’ that I have met on my education path who have helped me

along the way to achieve my education goals:

Professor Komla M. Nubukpo and late Professor Kézié K. Lébikaza,

because you believed in me;

My brothers and sisters Mani Gabriel, Yao Célestin, Assandi Denis,

Tchoougoulou Modeste, Tchilalo Véronique, Tcharalo Chantal, and Thomas Essolè,

because you believed in me. You put me to school and showed me that it was our way out of poverty to a better future, but little did you and I know how far it would take me;

I have gone it all the way through;

Sharleston Howells-Moss, because you were there for me;

Afi and Tete Amouh, because you were there for me;

The American Association of University Women, because you were there for me¹.

When I count my blessings, I count you twice!

To you, women and girls worldwide,

because I believe in you.

¹ Part of my graduate studies, which led to this research, were supported through an AAUW-EF International Fellowship 2004-2005.

ACKNOWLEDGEMENTS

I would like to thank the people who have encouraged and supported me during the long process of my graduate studies that culminated in this dissertation. Without your support, this study would not have been possible. First and foremost, I would like to express my gratitude to all those who have provided me with financial and emotional support all along this difficult journey; Sharleston Howells, Afi and Tete Amouh, and AAUW-EF. Thank you also to my brothers, sisters, and friends who have given me all kinds of support, kept faith in me, and taken pride in my education.

I would also like to thank a number of people who have helped with this research; Dr. Donal A. Burquest, who was on my research committee for a short period before retiring, read the proposal and gave me feedback; Lori McLain Pierce from UTA, for your hard work in giving me feedback on the written document; and all my research participants for readily providing me with speech for analysis in this study and showing a genuine interest in the results. Thank you for your time and effort.

Finally, I would like to thank in a particular way my dissertation committee; Dr. David J. Silva, my advisor, for your guidance with the design of the study, which made this project manageable; Dr. Jerold A. Edmondson, Dr. Laurel S. Stvan, and Dr. Michael Cahill from SIL International -Dallas. Sincerely thank you for your time and your invaluable comments that have guided me in improving the quality of this research.

April 16, 2010

ABSTRACT

A REVISED PHONOLOGY OF KABIYE SEGMENTS AND TONES

Cécile Mamalinani Padayodi, PhD.

The University of Texas at Arlington, 2010

Supervising Professor: David James Silva

This study suggests revisions to the segmental and tonal phonology of Kabiye following a reanalysis of consonants, vowels, and tones in the speech of 7 male native speakers. Acoustic investigations are also included to illustrate some phonetic aspects of segments and tone. Data were elicited through three speech styles – wordlists, short phrases, and storytelling – later transcribed and analyzed.

Revisions are made to the phonetic and phonemic inventories of consonants and vowels, as well as to the inventories of the underlying tonal melodies on noun roots, verb roots, and noun suffixes, as indicated by the results of the current study, which combines a more adequate methodology with newer phonological theories. In Kabiye, the surfacing of obstruents' underlying voicing specifications is known to be restricted in both initial positions where they are all realized as voiceless and in medial positions – in the simple root and after a morpheme boundary – where they have a tendency to surface as voiced. Under the current study, it is further found that contrasts in voiced and voiceless

obstruents are nonetheless kept in medial positions, but they are regulated by morphology. In medial position, there are voicing environments, which voice all the obstruents occurring after a morpheme boundary, but the underlying voicing specifications of obstruents also surface after a morpheme boundary in certain contexts, which are voicing-neutral environments. In the latter environments, the current study found voiced and voiceless obstruents occurring in contrastive pairs, with the exception of the obstruents in the bilabial and the retroflex subclasses. Consequently, these subclasses revealed themselves as defective, with only voiced phonemes. The analysis of nasals determined a nasal archiphoneme, which is now part of the phonemic system. The vocalic system is also found to include a vocalic archiphoneme, unlike in any of the previous studies. This underspecified vocalic segment, determined to be from consonantal origin, is the element underlying the vowels known previously as “pharyngealized” or “velarized” vowels, and replaces the unattested segment “/ɣ/” that appeared in previous studies.

Tone analysis determined four lexical tonal melodies on five groups of noun roots – one of which includes toneless roots – and five lexical tonal melodies on five groups of verbs roots, also leading to a revision of the tone classes of nouns and verbs. In addition to the various revisions, which affect the analyses of segments and tone at the phonetic and the phonological levels, basic acoustic illustrations have been included at various points in the current study to back up some phonological claims and to show the physical nature of pitch as the correlate of tone.

TABLE OF CONTENTS

ACKNOWLEDGEMENTS	iv
ABSTRACT	v
LIST OF ILLUSTRATIONS	xiv
LIST OF TABLES	xvi
LIST OF ABBREVIATIONS USED IN MORPHOLOGICAL GLOSSES.....	xix
Chapter	Page
1 INTRODUCTION AND PRESENTATION OF THE LANGUAGE	1
1.1 Introduction.....	1
1.1.1 The Need for More Systematic Studies.....	4
1.1.2 Implications of Inexhaustive Tone Investigations for the Writing System	5
1.1.3 The Purpose of the Present Study.....	7
1.1.4 Outlining the Dissertation	8
1.2 Linguistic Classification and Background.....	9
1.2.1 Language Affiliation	9
1.2.2 Historical and Geographical Background.....	13
1.2.3 General Overview of the Literature on Kabiye	15

1.2.3.1	Non-Linguistic Literature	15
1.2.3.2	General Linguistic Literature.....	16
1.3	Sketch of Kabiye Grammar	22
1.3.1	Syntax.....	22
1.3.2	Morphology	28
1.3.3	Noun Classes and Concord System	36
1.3.4	Syllable Structure and Segmental Structure of Morpheme	39
1.4	Conclusion.....	47
2 REVIEW OF PREVIOUS SEGMENTAL PHONOLOGY AND		
TONE ANALYSES		48
2.1	Introduction.....	48
2.2	Review and Assessment of the Segmental Phonology.....	48
2.2.1	Previous Analyses of Vowels	49
2.2.2	Assessment of the Analyses of Vowels	54
2.2.3	Previous Analyses of Consonants.....	61
2.2.4	Assessment of the Analyses of Consonants	68
2.3	Review of the Literature on Tone.....	73
2.3.1	Distinctive Tones and Lexical Tonal Melodies	74
2.3.2	Major Tonal Phenomena Found in the Literature	82
2.3.2.1	Downstep and Downdrift.....	82

2.3.2.2	Declination	86
2.3.2.3	Resistance.....	87
2.3.2.4	Assimilation	88
2.3.2.5	Dissimilation	90
2.3.2.6	Erasure.....	92
2.3.2.7	Polarization	93
2.3.2.8	Simplification.....	94
2.3.2.9	Other Tone Processes.....	94
2.3.3	Tonology of the Sentence	96
2.3.4	Assessment of the Previous Tone Analyses	96
2.3.4.1	Limitations of the Previous Analyses of Tone	97
2.3.4.2	Inconsistencies and Errors in the Literature.....	100
2.3.4.3	Lack of Phonetic Investigation of Tone	111
3	FRAMING THE RESEARCH: MOTIVATION AND METHODOLOGY.....	113
3.1	Motivation of the Present Research.....	113
3.1.1	Goals of the Research	113
3.1.2	Statement of the Research Questions	114
3.2	Methodology	115
3.2.1	Conceptual Approach and Theoretical Framework.....	115
3.2.2	The Subjects	118

3.2.3	Data Collection Procedure	119
3.2.4	The Analysis.....	120
3.2.5	Scope and Limitations.....	121
4	REVISION OF KABIYE CONSONANTAL PHONOLOGY.....	122
4.1	Introduction.....	122
4.2	Revised Phonetic Inventory and Classification of Consonants.....	123
4.3	Phonological Analysis of Consonants	125
4.3.1	The Phonological Status of the Approximants.....	126
4.3.2	The Phonological Status of the Liquids.....	128
4.3.3	The Phonological Status of Nasals	134
4.3.4	The Phonological Status of Obstruents.....	149
4.3.5	Voiced and Voiceless Consonant Alternations after a Morpheme Boundary	161
4.4	Conclusion of the consonantal analysis.....	178
5	REVISION OF KABIYE VOCALIC PHONOLOGY.....	182
5.1	Revised Phonetic Inventory and Classification of Vowels	182
5.2	Revised Phonological Analysis of Vowels.....	196
5.2.1	Front Vowels versus Back Vowels.....	196
5.2.2	Front Vowels Opposed by Aperture.....	197
5.2.2.1	High Vowels Opposed to Non-High Vowels	197

5.2.2.2	Non-Low Vowels Opposed to Low Vowels	197
5.2.3	Back Vowels Opposed by Aperture.....	198
5.2.4	Vowels Opposed by Tongue Root Position ([+RTR] vs. [-RTR]).....	198
5.2.5	Phonological Status of Long Vowels and Extra Long Vowels.....	200
5.2.6	Phonological Status of other Vocalic Elements and Diphthongs.....	209
5.2.6.1	Phonological Status of [y ɤ ø œ].....	209
5.2.6.2	Phonological Status of Diphthongs	210
5.2.6.3	Phonological Status of the Vocalic Elements [ɥ ɯ ɤ ʌ ɑ].....	214
5.2.6.4	The Status of a Phoneme /ɣ/ <i>vis-à-vis</i> the Vocalic Elements [ɥ ɯ ɤ ʌ ɑ].....	223
5.2.6.5	The Existence of a Vocalic Archiphoneme /K/ in Kabiye	225
5.3	Conclusion of the Revised Vocalic Phonology	232
6 ACOUSTIC DESCRIPTION & PHONOLOGICAL OVERVIEW OF TONE.....		237
6.1	Introduction.....	237
6.2	Acoustic Overview of Tone.....	238
6.2.1	Physical Nature of Tone.....	238
6.2.1.1	The F ₀ trajectory of the High Tone and the Low Tone	239
6.2.1.2	Trajectory and Fundamental Frequency of the	

	High-Low and the Low-High Tone Sequences.....	245
6.3	Phonological Analysis of Tone.....	248
6.3.1	Distinctive Tones and the Tone-Bearing Unit	248
6.3.1.1	The Tone-Bearing Unit	249
6.3.1.2	Distinctive Tones	251
6.3.1.3	Tone Association Conventions and Tone Rules.....	254
6.3.2	Tonal Melodies of Noun Roots	259
6.3.2.1	High Melody Noun Roots (/H/ roots).....	260
6.3.2.2	Low Melody Noun Roots (/L/ roots).....	263
6.3.2.3	Toneless Noun Roots (/T ₀ / roots)	266
6.3.2.4	High-Low Melody Noun Roots (/HL/ roots)	269
6.3.2.5	Low-High melody Noun Roots (/LH/ roots).....	272
6.3.2.6	Tonal melodies of noun prefixes and suffixes	275
6.3.3	Tonal Melodies of Verb Roots.....	279
6.3.3.1	High Melody Verb Roots (/H/ Roots).....	280
6.3.3.2	Low Melody Verb Roots (/L/ Roots)	281
6.3.3.3	High-Low Melody Verb Roots (/HL/ Roots).....	282
6.3.3.4	Low-High Melody Verb Roots (/LH/ roots)	284
6.3.3.5	Low-High-Low Melody Verb Roots (/LHL/ Roots).....	285
6.4	Conclusion.....	287

7 CONCLUSION	290
7.1 Overview of the Significant Findings.....	290
7.1.1 Consonant System.....	290
7.1.2 Vowel System	293
7.1.3 Contrastive Tones and Lexical Tonal Melodies.....	297
7.2 Directions for future research.....	299
Appendix	Page
A. TONAL FRAMES	302
B. WORD GAMES.....	304
C. SAMPLE SAMPLE NOUN ROOTS AND VERB ROOTS.....	306
REFERENCES	311
BIOGRAPHICAL INFORMATION	326

LIST OF ILLUSTRATIONS

Figure	Page
1.1 (a) Greenberg’s 1963a classification of Niger-Congo languages and (b) Grusi affiliation to Niger-Congo	11
1.2 Languages of Togo (Lewis (ed.), 2009. Online version: http://www.ethnologue.com/	14
2.1 First type of diphthongs (Lébikaza 1999: 43).....	50
2.2 Second type of diphthongs (Lébikaza 1999: 44).....	51
2.3 Comparative sketch of sample verb roots analyses by four different authors	80
2.4 Delord’s (1976: 37) diagrams showing tonal terracing in the sentence: (a) tonal phrase 1, (b) tonal phrase 2	85
2.5 Roberts’ (2002: 44) diagram of Automatic Downstep.....	86
2.6 Roberts’ (2002: 44) diagram of declination.....	87
5.1 Three valves of the larynx (Esling & Harris 2005 as reproduced).....	186
5.2 Kabiye laryngeal postures representing the temporal mid-point in the final.....	187
5.3 First type of diphthongs, constituted by an unrounded front vowel and an unrounded back vowel of the same aperture.....	192
5.4 Second type diphthongs, gliding from an unrounded front vowel or a rounded non-high back vowel to a rounded high back vowel.	193

5.5 Third type of diphthongs gliding from a rounded back vowel or an unrounded non-high front vowel to an unrounded high front vowel.	194
5.6 The Combined diphthongization possibilities of the vocalic system	195
5.7 Formant Plot of Kabiye Short Vowels in Bark	234
6.1 Pitch tracks of the high tone [H] on the short vowel [u] in [tú] ‘elephant’	240
6.2 Pitch tracks of the [HH] tones on the long vowel [ɪɪ] in [tʃíí] ‘tear-IMP’	240
6.3 Pitch tracks of the [L] tone on the short vowel [ɔ] in [tù] ‘bite-IMP’	242
6.4 The Pitch tracks of the low tones [LL] on the long vowel [uu] demonstrate a lesser slope in (a) and a more abrupt fall in (b) for [tùù] ‘crawl-IMP’	243
6.5 Pitch tracks of the high-low [HL] tone sequence on a long vowel [ɔɔ] in [ɲòtùù] ‘connect-INF’	245
6.6 Pitch tracks of the low-high [LH] tone sequence on a long vowel [ɔɔ] in the word [tànùù] ‘beard’	246

LIST OF TABLES

Table	Page
1.1 Noun Classes and their Concord Affixes.....	38
2.1 Phonetic Chart of Kabiye Vocalic Sounds (Lébiakaza 1999: 39)	49
2.2 Phonetic Classification of Vowels (Lébiakaza 1999: 42)	50
2.3 Basic Vocalic Phonemes Found in all Previous Studies	51
2.4 The Long Vocalic Phonemes According to Roberts and CLNK & SIL-Togo	53
2.5 Long Pharyngealized Vocalic Phonemes According to Roberts and CLNK & SIL-Togo.....	53
2.6 Consonant Phonemes According to Delord (1976: 23).....	62
2.7 Consonant Phonemes by CLNK & SIL-Togo (1998, p.1 of Esquisse...).....	62
2.8 Consonant Phonemes According to Lébiakaza (1985, 1999)	63
2.9 Consonant Phonemes According to Paaluki (1995: 17).....	63
2.10 Inventory of Consonant Phonemes According to Roberts (2002, 2003)	64
2.11 Kabiye Consonant Phonemes' Classification by Kassan (1996: 22)	64
2.12 Comparative Inventory of Underlying Tones	75
2.13 Resistance of VV, Vy and VN sequences (Roberts 2002: 46).....	87
2.14 Roberts Sample Derivation	90

4.1 Phonetic Table of Consonants Classification.....	123
4.2 Illustration of Consonants Distribution.....	125
4.3 Revised Inventory of Kabiye Consonant Phonemes.....	157
4.4 Verbs with Underlying Voiced or Voiceless Root-Initial Obstruents.....	166
4.5 Nouns with Underlying Voiced or Voiceless Root-Initial Obstruents.....	169
4.6 Illustration of Verb Root-Initial Bilabial and Retroflex obstruents.....	172
4.7 Illustration of Noun Root-Initial Bilabial and Retroflexes obstruents	174
4.8 Illustration of Verbs with Unclear Underlying Voicing Specification of Initial Obstruent	176
5.1 Illustration of Vocoids.....	182
5.2 Revised Classification of Basic Vocoids in Two Sets.....	183
5.3 Short Vocoids, Long Vocoids, and Extra Long Vocoids Illustrated.....	191
5.4 Verbs with First Type of Diphthongs Versus Alternating Forms	211
5.5 Second Type of Diphthongs Alternating with Other Vocoids in Verbs	211
5.6 Second Type of Diphthongs Alternating with Other Vocoids in Nouns.....	212
5.7 Words with Third Type of Diphthongs Versus Alternating Forms	213
5.8 Words with Third Type of Diphthongs as Object Suffixes.....	213
5.9 Back Unrounded Vowels versus Front Unrounded Vowels.....	215
5.10 Back Unrounded Vowels versus Back Rounded High	216
5.11 Examples of Same Words Pronounced with Different Vowels	216

5.12 Revised Inventory of Kabiye Vocalic Phonemes	233
6.1 Derivation of the Plural Form for ‘elephants’	261
6.2 Derivation of the Singular Form for ‘tail’	262
6.3 Derivation of the Singular Form for ‘pity’	264
6.4 Derivation of the Singular Form for ‘eye’	265
6.5 Derivation of the Singular Form for ‘food’	268
6.6 Derivation of the singular Form for ‘papaya’	271
6.7 Derivation of the plural Form for ‘grandchildren’	271
6.8 Derivation of the Singular Form for ‘mortar’	273
6.9 Inventory of Noun Suffixes and their Tonal Melodies.....	275

LIST OF ABBREVIATIONS USED IN MORPHOLOGICAL GLOSSES

Acc	:	Accomplished aspect maker (the French “ <i>accompli</i> ”)
Adjr	:	adjectival prefix
AG	:	agent marker
Anter	:	anterior marker
AUX	:	auxiliary verb
Dmcf	:	demarcative marker
EpC	:	Epenthetic consonant
EpV	:	Epenthetic vowel
FOC	:	focus marker
Immed:		morpheme of the Immediate
IMP	:	Imperative
Inacc	:	Inaccomplished aspect (the French “ <i>inaccompli</i> ”)
INF	:	Infinitive marker
LR~Pref:		location prefix (marker of location deverbal substantives or Relational Locatives)
MOD	:	modal verb
NEG	:	negation or prohibition morpheme
Pl	:	plural
Pref	:	prefix with no particular meaning

- PROG : modal verb for progressive
- RedAdv: redundant adverb
- Sg : singular
- VR : verb root
- # : represents morpheme boundary in rules
- ## : indicates utterance-initial, word-initial or word-final position in rules
- ^ : Links a grammatically complex form that is not segmentable.
- 1Sg : 1st person singular pronoun (“I”)
- 2Sg : 2nd person singular pronoun (“you”)
- 3Sg : 3rd person singular pronoun (“s/he”)

CHAPTER 1

INTRODUCTION AND PRESENTATION OF THE LANGUAGE

1.1 Introduction

Since the beginning of modern linguistics some decades ago, it has become increasingly appreciated that the diversity of the languages of the world is a rich human legacy that needs to be preserved. Indeed, while languages of the world share many universal properties, each language has specific characteristics (conceptualized as “parameter settings” by generativists) that make its grammar unique. Therefore, language description has become widespread as an important contribution to language preservation. However, to date, although many languages have been studied, described and written for centuries, most languages of the world still remain only spoken or under-studied and some are even extinct or on the way to extinction (Brenzinger 2007, Harrison 2007). Kabiye, one of the most widely spoken languages of Togo, falls into the under-studied languages category. Only a handful of studies to date have explored its morphological, syntactic, and phonological rules. Its tone system, which manifests complex rules, is even less studied and still needs in-depth investigation.

From lexical to sentential levels, the phonology of Kabiye manifests very interesting and complex segmental and tonal rules. Through the limited existing research on this language, it is now possible to envision some of the functioning of

segments and tones, but the language's sound system is still not yet wholly understood. Most striking are the many types of phonological alterations. Very commonly, some words are produced with a certain consonant when they appear in isolation, but surface with a different consonant when they are combined with other words into phrases and sentences. For instance, words such as [tóm] 'news, language' and [tʃàá] 'father' occur in isolation (as in a wordlist) with an initial voiceless stop; but in a phrase, these words are uttered with a voiced consonant as in [nèmé ɕʒàà dóm] 'news about Nèmé's father'. Yet, in another phrase, these consonants might not change, viz. [á-tʃàà dóm nèè] 'news about whose father?' Vowels and tones also show similar alternations. Typically, while the tonal patterns of some nouns remain consistent anywhere they appear (as illustrated by [pìjálú] 'son', [ná-bìjálú] 'your son', or [pà-bìjálú] 'their son'), the tonal patterns of many other nouns alternate between forms occurring in isolation and forms in included environment. The following nouns, for example, have tones as [tóónáà] 'food' and [hájúú] 'leaf' in a wordlist, but as [píjà dòónáà] 'children's food' and [pà-hàjùù] 'their leaf' following a low tone, and as [nó-dóónáà] 'your food' and [ná-hájúú] 'your leaf' following a high tone. Other manifestations of tonal alterations are also common, namely such tonal phenomena as downstep, downdrift, declination, etc., phenomena found in many African languages and described in work by scholars such as Welmers (1973), Stewart (1965), Goldsmith (1976), and Pulleyblank (1986), among others. Specifically, the tones of some Kabiye words illustrated by [èjú] 'man', [ènéné] 'this', and [pòj̀dónè] 'neck' may change in the phrasal environment to show evidence of downstep

as in [ɛ̀jú 'éne] ‘this man’ or [ɲó-¹bóɲd ónè] ‘your neck’. In a longer syntactic unit such as the sentence, tones of words may show further alternation as they relate to the following or the preceding morphemes, thus exhibiting other phrase and sentence level rules. Moreover, the tonal system is rich with the potential for testing many other theoretical claims. For both the tones and the segments, the change seems to depend on the type of the element involved – type of consonant, type of tone or type of melody – and the environment in which they appear, such as the position of the word in the utterance and the tonal melody of what precedes and what follows it.

Although the Kabiye language is already represented by several studies of segments and tones, mainly by Delord (1976), Lébikaza (1985, 1999), Roberts (2002, 2003), and CLNK & SIL-Togo (1998), these descriptions have not reached a unified conclusion on many phonological issues. The results are as diverse as the studies, as will be shown in the literature review; and also include misinterpretations that still need to be addressed. Very often, the strategies used by these previous accounts to uncover the deep structure of segments and tones are not fully systematic and the ensuing analyses have missed generalizations. Therefore, these studies are not always reliable. In this context, the research in these foundational studies needs revision in order to better explain the tones and segments and their underlying configurations. The processes that yield the corresponding surface forms also need to be determined. The present research is proposed for this end: it will further shed light on Kabiye segments and tones by improving various points from the previous studies and contributing new generalizations.

1.1.1 The Need for More Systematic Studies

The existing major descriptions of Kabiye are broad in the array of topics they cover, but show a lack of in-depth investigation of individual topics (including tone and segments) and consequently often reach partial results or results that are only partially true (Delord 1976 and Lébikaza 1985, 1999). Given the large number of topics they discuss, it is not surprising that these studies do not investigate each topic in full depth. Tone and segments in these descriptions are usually studied along with other topics such as syntax, morphology, etc. The descriptions also fail to be systematic in their methodologies, (for example, Delord 1976), leaving them only relatively detailed, a concern that also applies to newer studies such as Roberts 2002, 2003. Therefore, some of the conclusions of these works may not stand because they are based on potentially faulty assumptions.

Because of methodological weaknesses leading to unclear results in the previous studies, they do not constitute a solid foundation upon which newer studies can build – as they should – without first revisiting the data and analyses. In fact, among these previous studies, some of the later works attempted to correct the errors they found in the earlier ones by reinvestigating the same topics, but they have arguably fallen short as well, mainly because they also lack systematicity in their investigations. Specifically, Lébikaza's works (1985, 1999) revisited most of the topics investigated in Delord 1976, which include the phonological analysis of sounds and tones, but missed some important conclusions about certain segments and lexical tones. Likewise, Roberts 2002

began by showing a new phonological analysis of the sounds of the language and redefining the basics of tone before exploring the tone classes of Kabiye verbs, but this work can be viewed as problematic because it does not show any detail of its phonological analysis of the segments. Consequently, the analyses of segments and tones in Kabiye would benefit from further investigation for more reliable conclusions.

1.1.2 Implications of Inexhaustive Tone Investigations for the Writing System

One consequence of the lack of studies that lay out all of the intricate tone rules and make available a full understanding of how they work can be seen in the lack of tone representation observed in the writing system, even three decades after the writing started.

Since 1978, when schools began the teaching of Kabiye as an elective subject, tones have systematically been ignored in the practical orthography. This writing system is generally very close to the IPA (International Phonetic Alphabet) on which it is based, but departs from the IPA in a few cases and also uses several glyphs from Latin script. For example, the IPA [tʃ ɟ ɲ j tʃ] are represented by the glyphs <c j ɲ y d>, respectively. Tones, however, are not reflected in the writing system. Moreover, tone has received no attention from those who designed the various pedagogical materials and other documents in the language.

This lack of tones in the orthography appears to be critically affecting the reading and writing of the language, thus unfortunately jeopardizing the efforts of standardization (CLNK, p.c.). As a matter of fact, during the data collection for the

current study, even trained native speakers of Kabiye are unable to read their own language as fluently as they read non-tone languages, such as French and English, which they have learned in schools. They are often faced with uncertainty when it comes to choosing the right tones of the words, especially when the meaning of these words cannot be inferred from context, which leaves them simply guessing at the tone combinations. Absence of written tones makes it very challenging for speakers to read a text without hesitation. This phenomenon of guessing at the unwritten tones in a text is actually not particular to Kabiye readers. The same phenomenon occurs in other tone languages such as Bassa of Liberia, about which Welmers stated:

It has proven far too easy to underestimate the importance of indicating tone. In recording a Bassa (of Liberia) reading of a portion of the Bible for broadcast purposes, it was noted that, no matter who the reader was, he could record only one sentence at a time; for each sentence, he had to experiment with various combinations of tone before settling on a combination that seemed the most reasonable (Welmers 1973: 118).

The same can be stated of Kabiye. In church services, leaders reading Kabiye translations of biblical passages prepare for every reading for long periods of time by experimenting with various combinations of tone, then settling on the one that makes the most sense before reading it aloud to service attendants.

It appears that without orthographic tone marking, the written text of a tone language is missing a key component without which the language becomes mostly unrecognizable, even to native speakers. Indeed, a “tone language” cannot be whole and understandable without tone. Nonetheless, a great many African languages in their

practical orthographies have “chosen” not to use tone marking. In such languages as Somali for example, tone may not play a vital role. In many cases, tone can be inferred from stress. More generally, Somali presents very few cases of lexical or grammatical forms differentiated by tone only. Such varying practices indicate that from language to language, tone varies in importance; in Kabiye, however, it is vital. It is apparent that leaving it to readers of Kabiye to infer the tones of words was an unrealistic expectation based on native speakers’ competence. In addition, the needs of potential Kabiye second language learners are not being met.

Because the importance of tone in Kabiye and the necessity to show tone in the writing system is now better understood, a more urgent need is felt by researchers to thoroughly study the tone system of the language and describe it in fuller detail. As a result, more recent tone studies have been conducted on this language. These studies not only attempt to show tone by means of diacritics in their Kabiye transcriptions, but also actively research and describe the tone of this language to uncover rules, with some focusing also on devising adequate tone representation in the writing system (Roberts 2008). Moreover, it is necessary to go beyond mere descriptions to formulate rules of tones that seem complex and are still not well understood. This is the primary task that the present project, following the steps of recent studies, seeks to undertake.

1.1.3 The Purpose of the Present Study

Building on previous works, the research undertaken here strives to further refine the description of Kabiye segments and tones. The current account aims at

contributing some important generalizations that have been missed in the existing descriptions of the basics or the fundamentals of tones and segments. It also seeks to address some errors found in some of these foundational works. Therefore, a revision of segmental and tonal phonology is proposed to address the missed generalizations and errors in the existing accounts in order to achieve descriptive accuracy, clarity, and coherence. The current study, however, further expands to include unstudied areas of tone and segments.

More specifically, this study will pursue three goals: 1) to contribute better generalizations to the analysis of Kabiye segments and tone, 2) to address the misinterpretations of the fundamentals of tone and segments found in previous studies, and 3) to investigate some tone areas previously not explored, by showing the physical nature of tone through pitch tracks and F_0 correlate of tone, from an acoustic phonetics perspective, which makes use of the new research tools available for a complete and more accurate analysis.

1.1.4 Outlining the Dissertation

Based on the research goals to be achieved, this dissertation is structured as follows. After this chapter, which introduces the language and its speakers as well as the research, the previous studies on Kabiye tone and sounds will be reviewed in detail in Chapter 2 to highlight their strengths and assess their weaknesses. It will be followed in Chapter 3 by an explanation of the methodology adopted in the present analysis. The fourth chapter will revisit and revise the consonantal phonology while the fifth chapter

will be devoted to a revisit and revision of the vowels. Chapter 6 will offer the beginnings of a new phonological account of Kabiye tones as well as an acoustic description of tone. A final chapter will provide an overview of the significant findings of the study.

The remainder of this introductory chapter includes a presentation of the historical, cultural, and geographical settings of the language and its speakers as well as its linguistic background. A sketch of the grammar, which includes syntax, morphology, and syllable structure, is also presented in order to provide the reader with some general knowledge of the language.

1.2 Linguistic Classification and Background

This section presents the linguistic, historical, and geographic background of Kabiye. It also details its language affiliation and overviews the existing literature on the language.

1.2.1 Language Affiliation

Kabiye is a Gur (Voltaic) language that belongs to the Eastern Grusi² sub-branch of Central Gur, which in turn sub-branches from Gur that is part of the greater Niger-Congo language family (Naden 1989: 143-147 in J. Bendor-Samuel ed.). Other names of this language have been listed in the literature as Cabrai, Cabrais, Kabre, Kabure,

² Grusi is also known as ‘Gurunsi’ in other works such as Heine and Nurse 2000: 26, Manessy 1962, 1969, 1979, and Koehler 1952.

Kabye (Delord 1976, Lewis 2009), Kabré, Kabiyé, Kabiye (Verdier 1960, 1974); Kabrè, Kabiye (Delord 1976), and Kaure (Koelle 1854). The classification in Figure 1.1 (a) shows where Gur fits in the sub-branching of the Niger-Congo language family in Greenberg's classification (Greenberg's 1963a in Williamson 1989) while Figure 1.1 (b) illustrates the hierarchical relationship of Eastern Grusi to Niger-Congo and ultimately to the larger Niger-Kordofanian³ as found in Naden 1989.

³ Also appearing as “Niger-Kordofanian (or Congo-Kordofanian)” in Heine and Nurse 2000: 15 reporting Greenberg.

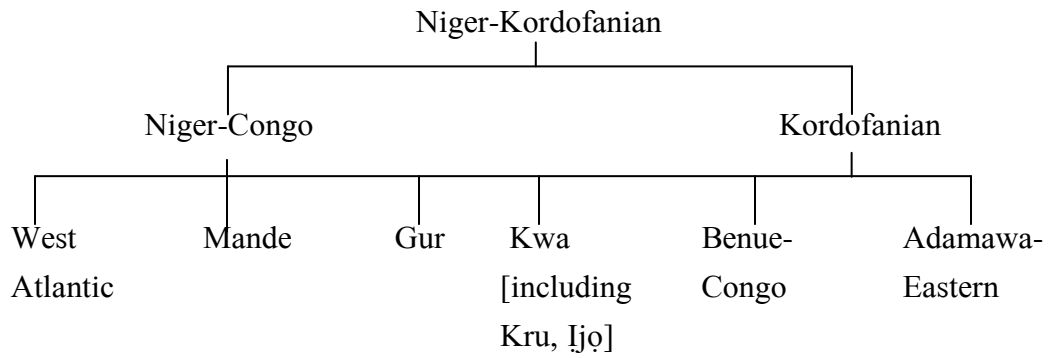

(a)

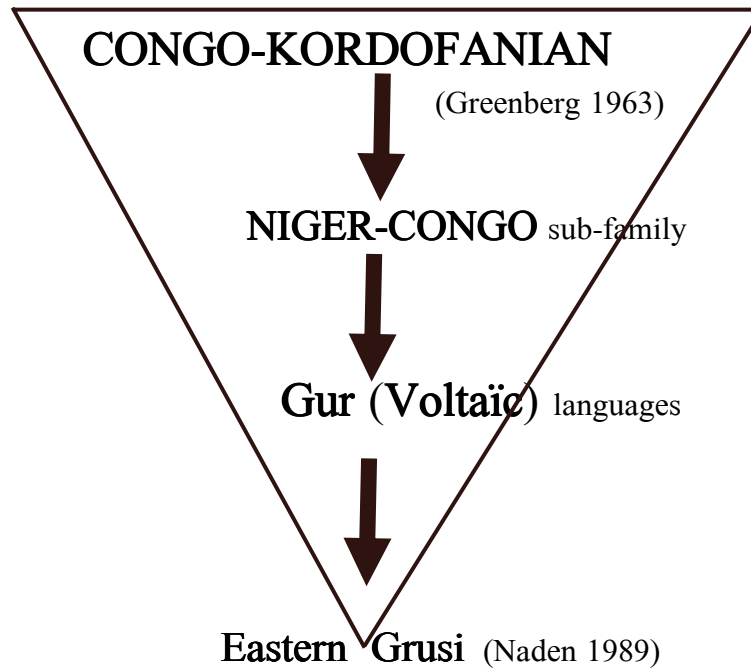

(b)

Figure 1.1 (a) Greenberg's 1963a classification of Niger-Congo languages and (b) Grusi affiliation to Niger-Congo

The regional varieties of Kabiye have been grouped into four types according to their geographic positions within the Kabiye area: Kèwe in the center, Lá'máqísi to the North, Lɪkpá to the East, and Lámba to the West (Delord 1976: 2). However, Lébikaza (1999: 33) raised a good point in questioning this classification and advocating that it should be revised to distinguish Sirka from Lɪkpá and also include Yaka and Defale as other dialects of Kabiye. Tem could also be suggested as another dialect of Kabiye, given an important part of the lexicon they share and their many syntactic similarities. However, it must be agreed with Lébikaza that the issue of classifying Kabiye dialects can only be resolved after additional systematic dialectological research.

As a language with a limited literature and only a recent history of writing, no one of the Kabiye varieties has been clearly established as the standard. However, Kèwe, which is considered the most prestigious variety of the language and the variety with the largest number of speakers, functions as the *de facto* provisional standard. It represents Kabiye as a whole to the outsider and is often learned and adopted by the speakers of the other three varieties. It is also the variety that is taught in schools and, therefore, the variety of Kabiye illustrated in this dissertation, following other linguistic studies from which the known grammar is sketched in section 1.3. However, the general literature on Kabiye, which is overviewed in the following section, talks about the speakers and their language as a whole without dialectal distinctions, and covers a variety of topics.

1.2.2 Historical and Geographical Background

According to Lébikaza (1999: 33), who was reporting the numbers from the Statistics Office of Lomé (Bureau des Statistiques de Lomé), Kabiye speakers (non-natives included) represent 23% of the population of Togo. The native speakers of Kabiye are estimated at 730,000, with approximately 700,000 living in Togo, 30,000 in Benin, and a small number in Ghana (Lewis 2009). Their original homeland is Northeastern Togo, with the region of Kozah serving as the community's cultural center. From the early twentieth century, this community began to spread southward and now encompasses locations in the central and southern parts of Togo, as well as in the neighboring countries (Ali-Napo 1997: 20). Today, Kabiye speakers represent the second largest ethnic group after the Ewe in Togo, where both languages have been sharing the higher status of national languages since 1975.

Figure 1.2 shows the languages of Togo and the locations where they are spoken. Kabiye, represented by the number 20, appears in seven different locations across the country from the Mid North East through the South.

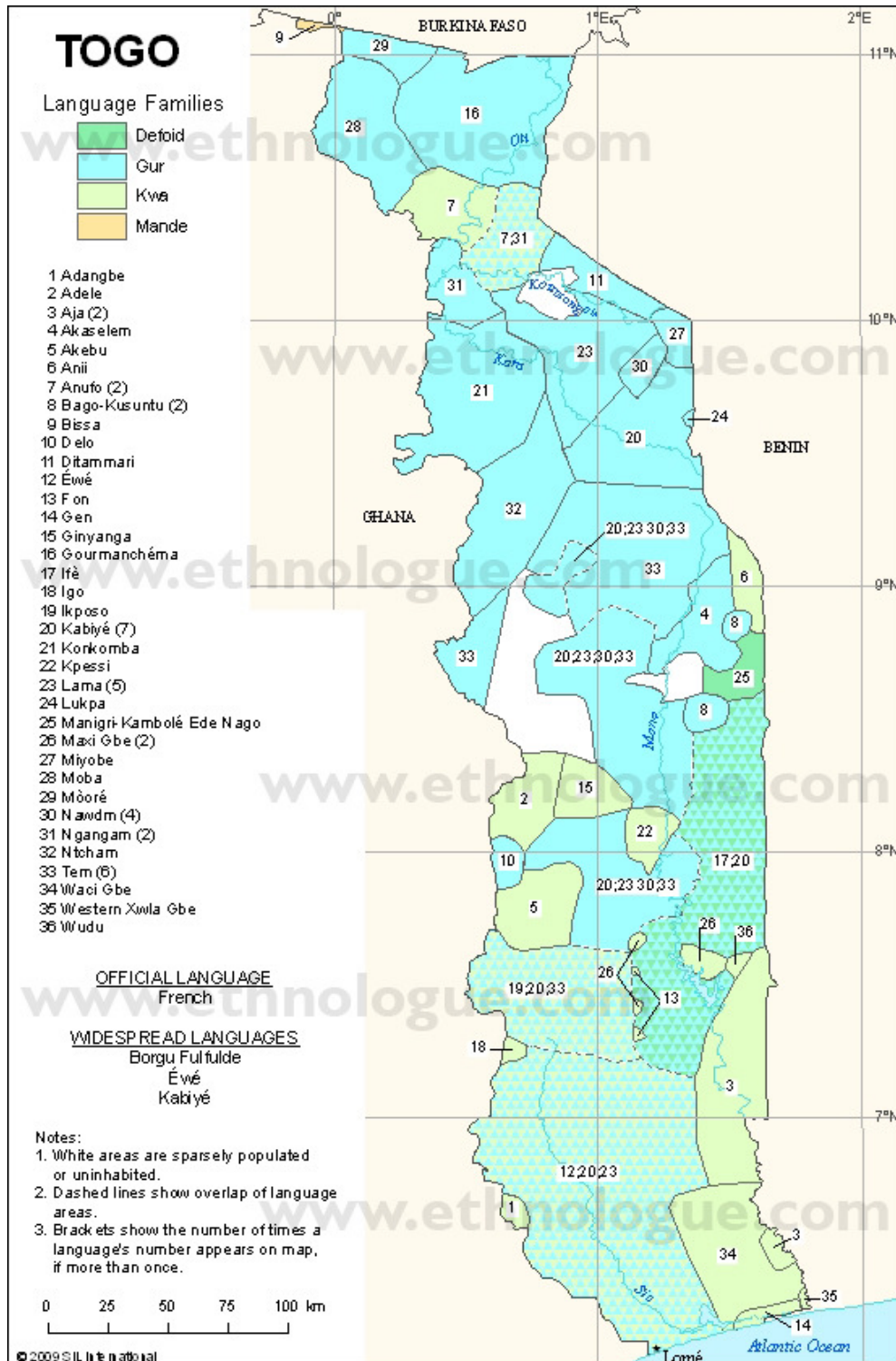

Figure 1.2 Languages of Togo (Lewis (ed.), 2009. Online version: <http://www.ethnologue.com/>

1.2.3 General Overview of the Literature on Kabiye

Studies on Kabiye are relatively recent and few. Nearly half of these studies are linguistic accounts while most of the remaining studies are cultural and anthropological in nature. These sections overview the research on the language from the general works to the more specific linguistic studies. To better serve the purpose of this research, this review of the literature on Kabiye will distinguish between the non-linguistic literature and the linguistic literature.

1.2.3.1 Non-Linguistic Literature

The major part of the non-linguistic literature on Kabiye tends to focus on one of four main topics: beliefs, music, cultural and historical settings, and farming.

The literature on beliefs ranges from topics on human destiny and death to God and the sacred within the Kabiye people (Verdier 1975, 1981, Larson 1984, Alou 1984, Piot 1993, Kao 1993a, 1993b, 1993c, Adji 1996) as well as reports of stories that recount the legendary Kabiye popular culture (Cridel 1968a, 1968b). Musical literature mainly constitutes the written review by Ménard (1974) of the audio musical pieces of Verdier (1960 / 65 / 66 / 72, 1967, Larson 1991), which sample the musical instruments of the Kabiye people in Ocora 76. The cultural, anthropological, and historical literature discusses topics from the settlement pattern and the ecological and cultural settings to the general history of the Kabiye natives via details of their kinship relations in the Slave Trade (Larson 1985a, Larson 1985b, Piot 1996, Kao 1999). In the area of farming, one counts a doctoral dissertation by Farnham (1994), which explores the

evolution of the farming techniques of the Kabiye natives and shows how the Kabiye and the Lamba underwent a transitioning from hoes to plows in a case study of a government-sponsored land settlement project.

1.2.3.2 General Linguistic Literature

The linguistic literature on Kabiye ranges from core linguistic analyses to teaching materials on the language and popular reading or literary documents written in Kabiye. Virtually all of this literature dates from the second half of the nineteenth century. Two outstanding works by Delord and Lébikaza in the core linguistic areas of phonology, syntax, morphology, and semantics have laid a foundation for the research on the language. But lesser extensive works from the same authors and from others researchers have further contributed to the description of Kabiye in the same core linguistic areas and in other fields of linguistics such as discourse analysis, sociolinguistics, lexicography, and comparative studies.

Delord 1976, the first significant linguistic description devoted to Kabiye, is a broad description that covers almost all aspects of the language. The work is organized into five main parts, the first of which gives a phonological account of the segments and tone systems. The second part analyzes the simple phrase from a functional approach, and shows its major and minor structures such as lexical functional units. The rules governing the combination of morphemes⁴ are described in the third part while the

⁴ Described as “monème” in French.

fourth part is devoted to the morphological description. The fifth part presents the syntax of the phrase and the sentence followed by a closing appendix in which Delord gives a comparative morphological analysis of today's Kabiye and the "Kaure" examined by Koelle (1854).

Almost a decade later, following in the steps of Delord, Lébikaza embraced the description of the grammar of Kabiye in a doctoral dissertation written in German (Lébikaza 1985) that was later expanded and published in French (Lébikaza 1999). His description also analyzed the phonology, the morphology, the syntax, and the semantico-pragmatic aspects of the language, providing a more in-depth account. The phonology section presents a step-by-step analysis of the consonants and vowels, which includes a phonetic inventory and a phonological analysis. It is followed by an analysis of tones – both underlying and surface tones – and other suprasegmentals or "prosodic units" such as accent, pause, and intonation. His treatment of morphology and syntax is combined in a subsequent lengthy discussion entitled "morphosyntax," in which he provides a description of the syntax and the morphological structure of word classes such as verbs, substantives, adjectives, adverbs, idiophones, pronouns, etc.

The other treatments found besides the descriptions of Delord and Lébikaza are less extensive in their scope (focusing on smaller topics), some of which are very succinct. Among these are a couple of phonological synopses in the introductions of the glossary of Paaluki and of the dictionary of CLNK & SIL-Togo, recent studies by Roberts, and articles by Kassan. Given the importance that these phonological studies

bear on the topic of the current research, they will not be reviewed here, but a more in-depth review of the phonological analyses of tone and segments specifically, as found in the works of Lébikaza and Delord as well as in other works, will be separately presented in Chapter 2.

A number of analyses have explored various aspects in morpho-syntax and semantics. A few of these analyses describe the verb system of Kabiye and its related tense, aspect, and mood systems, pointing out their fundamental characteristics (Kassan 1996, Lébikaza 1998) and at times also comparing them to those of the sister eastern Grusi languages (Lébikaza 1996). Another work by Lébikaza (2000) discusses the semantic properties of verbs and their constraints on the tense-aspect-mood categories. The syntax of the verb focus construction is the subject of study in Collins & Essizewa 2007. After comparing verb focus to subject focus and object focus to show how the three differ in the language, the authors propose an analysis of verb focus as stemming from a copy of the verb followed by movement to a low focus position. The main difference between this analysis and earlier works, which had already discussed the topic, is that the syntactic analysis of Collins & Essizewa explains how verb focus as well as subject focus and object focus are constructed in Kabiye from a more theoretically based approach. This is unlike Lébikaza (1999: 505–510) who adopts a morpho-semantic-syntactic description, hence determining what the parts of speech involved in these focus constructions are and also defining their nature and the internal structure of the whole construction. Likewise, Kassan (1996: 202–266) elaborates more

on this topic and draws a distinction between focus and emphasis that neither Lébikaza nor Delord, who also briefly mention focus particles, have made. Kassan's work also defines the discourse value of these constructions. In another dissertation, Samah (2002) devotes some attention to the cultural and linguistic challenges involved with a task of translating the Bible into Kabiye.

The morphological and semantico-syntactic characteristic properties of various functional words and constructions have also received attention in some works. Lébikaza 1998 focuses on the item NA bringing out its multifunctional properties as a “syntactic relator” endowed with functional polysemy. Other studies emphasize the constituents and internal structure of such constructions as predicative, nominal, and attributive possessive constructions while also highlighting the relationships that exist between these constituents and the type of possession expressed. Two articles, Lébikaza 1991 and Heine & Lébikaza 1997, focus on the grammaticization of *té* ‘home’, as it evolved from a simple noun into a marker of possessive construction, which in turn contributed to the creation of an alienable/inalienable or transferable distinction of type of possession in the language. Similar characteristics and properties are the subject of discussion in Lébikaza 1996/1997, which argues for the existence of a class of substantives with a particular status known as location deverbal substantives or “relational locatives”, a class that morphologically and syntactically behaves differently from other substantives. Lébikaza 2003 shows that the semantic complexity created by the combined existence of the latent feature [locative] plus the habitual nature of an

associated activity triggers a transition in some substantives so that they must be appropriately reanalyzed as relational locatives. According to the paper, this process frequently encountered in Kabiye is also borne out in Biali, another Gur language from Northern Benin, as well as in Ewe, a Kwa language. Other comparative studies include Lébikaza 2005, which compares the deictic categories in particles, demonstratives, and possessive constructions of Kabiye to those of other Gur languages.

Although most of the morphological description of Kabiye is owed to the two main works of Delord and Lébikaza, other morphological descriptions also exist, including an earlier work by Delord (1974) which presents a shorter version of what he later details in his 1976 work. Subsequent researchers in this area focused on the morphology and the onomastics of proper names. Two papers were thus produced by Kassan, the first of which (Kassan 2001a) discusses the contribution and the role of predicative, injunctive, and interrogative structures in the formation of Kabiye proper names. Her second paper (Badameli-Kassan 2001b) focuses on determining the characteristic morphological elements that distinguish between Kabiye male and female proper names. A dissertation by Pere-Kewezima (2004) discusses a lexico-semantic approach of the Kabiye onomastics. Welmers 1973 and Koelle 1854 are two older morphological works in which Kabiye is only briefly mentioned.

A few phonetic and sociolinguistic studies, as well as discourse analyses, have focused on the language. Most phonetic references to the language appear as minor comments within phonological accounts. Stand-alone phonetic studies are very recent

and scarce; only two papers were found. The first, by Merchant Goss and Doran (2003), examines the voicing of stops in Kabiye and pinpoints some of the phonetic factors involved in the distinction between voiced and voiceless stops. Kabiye is addressed from a purely phonetic perspective in Edmondson and Esling 2006. This research examines and compares the valves of the throat and their functioning in tone, vocal register, and stress in laryngoscopic case studies of three languages, Somali, Bai and Kabiye. The sociolinguistic research focuses on the politics of language planning (Kozelka 1984 a PhD dissertation, Lébikaza 2003) and language contact phenomena in Togo, which involves either Kabiye and French (Lébikaza 1992) with the latter as the official or education language, or Kabiye and Ewe as the two national languages (Essizewa 2006, 2007). As discourse analyses, one finds the dissertation of Kassan (1996) and two older works that compare dialects of Kabiye (Karan 1983) or adult and child narrative discourse (Marmor 1980).

The status of Kabiye as the second national language in Togo undoubtedly also encouraged research on this language with the production of three bilingual dictionaries (Brungard 1937, Lébikaza 1979, and MENRS/CLNK and SIL-Togo 1998) and a variety of didactic and literary materials. Among the most recent are two articles by Roberts (2008a, 2008c) and his doctoral dissertation (2008b). Others include Adjola 1978, Sedlak 1980, Sedlak and Jassor 1980, Tchangai 1983, research from DIFOP, and the many bi-annual publications of the Comité de Langue Nationale Kabiye in their journal “Èbe Laba” (ÈBE LABA N°15, N°18, etc.). Other publications such as the publications

of the Club de Langue Kabiye (Tɛbiye N°8, N°10, N°11, etc.) and Kao 1990, 1991a, 1991b, are more literature oriented.

As is evident from this overview, there exists a certain amount of literature on Kabiye, but linguistic descriptions are still few. Of all the researchers on this language, Lébikaza is by far the most prolific with a Kabiye-German dictionary, a dissertation, a book, and over a dozen of articles in various subfield of linguistics. He is closely followed by Roberts whose works are more recent and include a dissertation, two theses, and a few papers. But Kabiye is gaining more and more interest from researchers with a few other dissertations and some recent phonetic research papers. The bulk of these linguistic descriptions have established the grammar of Kabiye as it is known today, a sketch of which is given next.

1.3 Sketch of Kabiye Grammar

This section is intended as a brief description in order to give to the reader a basic understanding of the known grammar of the language: syntax, morphology, and syllable structure.

1.3.1 Syntax

Kabiye is predominantly an SVO language. According to Collins & Essizewa 2007, the sentence of Kabiye without focus has an SVO structure, where the auxiliary comes between the subject and the main verb, as in [S Aux V O]. The following sentences illustrate this structure.

- (1) [tʃàá níú kàbìjè]
 father understand Kabiye
 ‘Father speaks Kabiye’ or ‘Father understands Kabiye.’
- (2) [háú zìbí 'hájím dàá]
 dog die farm in
 ‘The dog died on the farm’
- (3) [è- gbém dètè]
 3Sg^1SgT1- go^home yesterday
 ‘S/he went home yesterday’
- (4) [tá- ɕʒàà híziù nándù]
 1Pl father cut meat
 ‘Our father is cutting meat.’

However, it must be added that while the SVO constituents order is rigid in the simple sentence, more complex sentences such as those using an auxiliary or cases of focus marking can also call for an SOV structure, as seen in the example (5)b. When an auxiliary is used, only the main verb can be moved after the object.

- (5)
- a. [tá- ɕʒàà dèm híziù nándù]
 1Pl father MOD^finish cut meat
 ‘Our father has finished cutting meat.’
- b. [tá -ɕʒàà dèm nándù híziù]
 1Pl father MOD^finish meat cut
 ‘Our father has finished cutting meat.’
- (6)
- a. [è- rànà nówú lím]
 3Sg^1SgT1- PROG drink water
 ‘He is drinking water.’

- b. [è- ʦàùná lím ɲòwó]
 3Sg^1SgT1- PROG water drink
 ‘He is drinking water.’

Focus and emphasis can be made by means of the markers *jó*, *lé*, *kènɛ́* (also *kèná* or *kàná*) or *ná*, and *té* (Lé bikaza 1999: 505-509). While subject focus is conveyed through the use of the focus marker *na*⁵ immediately following the verb as in (7)a, which is almost identical in meaning with (7)b, complement focus and verb focus make use of topicalization and copy strategies. In the case of complement focus, the object NP and the PP may still appear after the verb, as shown in (8)a, (8)b, (9)a, and (9)b, in which case they are followed by the marker *kèná*⁶ or its short form *ná*. They may be topicalized and followed by the marker *kè* (Lé bikaza 1999: 505, Collins & Essizewa 2007: 193) as shown in (8)c and (9)c. When topicalization is used, the focus marker can be replaced by a “syllabic compensatory lengthening” as in (8)d and (9)d. Also note that when the marker is omitted, or only part of the marker is omitted, there is the possibility of also adding the demarcative to the construction. When the focus is not on a constituent but on a whole question, it is done with the marker *kèté* or *té*, which is placed at the end of the question as in (10).

⁵ Whether the focus marker *na* is a particle on its own or a suffix on the verb depends on the analysis. In the analysis of Lé bikaza (1999: 507), *na* is a suffix on the verb, but in Collins & Essizewa 2007, *na* is a particle that follows the verb.

⁶ Following Collins & Essizewa 2007, we note the similarity between the focus markers *kè* (immediately following the clause initial focused constituent) and *kènɛ́* (as a clause final verb focus particle, see (11)).

(7)

- a. [tʃàá níú ná kàbìjè]
father understand FOC Kabiye
'Father is the one who understands Kabiye.'
(As an answer to the question: 'Who understands Kabiye?')
- b. [tʃàá 'ɾéké níú ná kàbìjè]
father only understand FOC Kabiye
'Father is the only one who understands Kabiye.'

(8)

- a. [tʃàá níú kàbìjè kèná]
father understand Kabiye FOC
'It is Kabiye that father understands'
(As a corrective answer to the question: 'Is English what father understands?')
- b. [tʃàá níú kàbìjè -è ná]
father understand Kabiye -Dmcf FOC
'It is Kabiye that father understands.'
- c. [kàbìjè kè tʃàá níú]
kabiye FOC father understand
'It is Kabiye that father understands'
- d. [kàbìjè -è tʃàá níú]
Kabiye -Dmcf father understand
'It is Kabiye that father understands'

(9)

- a. [háú zìbí 'hájím dàá kéná]
dog die farm in FOC
'It is on the farm that the dog died'
- b. [háú zìbí 'hájím dàà ná]
dog die farm in FOC
'It is on the farm that the dog died'

- c. [hàjím dàá ké háú sìbá]
 farm in FOC Dog die
 ‘On the farm is where the dog died.’
- d. [hàjím dàà -à háú sìbá]
 farm in -Dmcf Dog die
 ‘On the farm is where the dog died.’
- (10) [tʃàá lákì èbè -è té]
 father do what -Dmcf FOC
 ‘What is father doing?’

Verb focus is realized in two ways. When the predicate is reduced to the bare verb or the auxiliary plus the verb, the focus occurs by using *kènɛ́* after the verb as in (11)a. As Lébikaza (1999: 508) reports, in the presence of an object as shown in (12)a, topicalization of the object is necessary in order to free the space immediately after the verb for the focus marker *kènɛ́*, which must follow the verb. In this case, the introduction of the object anaphoric resumptive pronoun is essential given that the SVO structure is relevant for a proper attribution of their functions to the topicalized object and to the subject. But verb focus can also be done by means of a “modal adverb” (Kassan 1996: 245) from the particular class of words also called “redundant adverbs” (Lébikaza 1999: 445). Such an adverb is made up of the prefix *kí-* (or particle, in the terminology of Collins & Essizewa 2007)⁷ followed by the copy of the root of the verb

⁷ In Collins & Essizewa 2007, this prefix is rather analyzed as a particle, another focus marker by itself, which is then followed by the copy of the main clause verb with the Infinitive suffix [-*ɔ*], and “placed at the end of the verb phrase following the particle glossed *kí*.” It is necessary to mention here though that the suffix of such a copied verb is actually not always identical to the “Infinitive” suffix, but a form only close to the Infinitive, which is more consistent with the suffix identified in Kassan 1996 and Lébikaza 1985, 1999.

to be modified (or the main verb), and the suffix *-ú/ù*, as appearing in (11)c, (12)b and (13).

(11)

- a. [pí'já ɔ́záú lè̀jìú kèné́]
 kids MOD^want play FOC
 'kids are only going to play'
- b. [pí'já lé'jìú kèné́]
 kids play FOC
 'kids are only playing'
- c. [pí'já lé'jìú kí- lè̀jìú pà-à jòwù kí- 'jówú]
 kids play RedAdv- play 3PI^2PIT1-NEG fight RedAdv- fight
 'Kids are only playing, they are not fighting'

(12)

- a. [mílú é-nú pà- màbá -í kéné́]
 thief 3Sg-that 3PI^2PIT1- beat -him FOC
 'That thief was (actually) beaten'
- b. [mílú é-nú pà- màbá -í kí- 'máb-ú]
 thief 3Sg^1SgT1-that 3PI^2PIT1- beat -him RedAdv- beat-INF
 'That thief was (actually) beaten'

(13) [tʃáá níú kàbìjè -è kí- 'níw -ú
 father understand Kabiye -Dmcf RedAdv- understand -INF
 'Father only understands Kabiye,...

ì- ì- jò̀d̀d̀d̀ù -gú]
 3Sg^1SgT1- NEG- speak -it
 ... he does not speak it'

1.3.2 Morphology

Lexical items in Kabiye (nouns, verbs, adjectives, adverbs, etc.) are usually polymorphemic. They are often composed of a derivational root that is expanded by derivational suffixes and prefixes⁸.

Verb roots can be expanded by the addition of morphemes of tense, aspect, and modalities⁹.

(14) From /təl-/

- a. [təl -í -ù] ‘to arrive’
arrive -EpV -INF
- b. [təl à -á] ‘arrived’
arrive -EpV -Acc

(15) From /k̀p̀em-/

- a. [k̀p̀ém] ‘to go home’
go^home^INF
- b. [k̀p̀é̀] ‘goes home’
go^home^Inacc

(16) From /sé-/

- a. [sèw -á] ‘ran’
run -Acc
- b. [é- dàà- sé -ỳ] ‘Do not run!’
2Pl NEG- run -Inacc

⁸ The morphological glosses for noun suffixes in the examples throughout this document refer to the classification in Table 1.1.

⁹ The term ‘modalities’ as used here refers to the “ways in which the ‘attitude’ of the speaker is grammatically marked in languages” (Lyons 1968: 308 cited in Lébikaza 1999: 308).

Other word classes such as substantives, adjectives, and adverbs are commonly derived from verb roots. Only a handful of these classes do not derive from verb roots.

Substantives¹⁰ are formed from noun roots or verb roots that function as derivational bases, to which derivational suffixes are often attached. They are consequently referred to as nominal substantives and deverbal substantives (in French, “*substantifs dénominaux*” and “*substantifs déverbaux*” in Lébikaza 1999: 371-372). At times, both a derivational suffix and a derivational prefix are attached to the root. Suffixes that are used to derive nouns and substantives also serve as class markers (Table 1.1).

Denominal substantives include three types, namely the substantives designating a status or a quality (see (17)a. vs. (17)b.), collectives ((18), (19)), and those designating diminutives and augmentatives ((20)b, (21)b, (20)c and (21)c).

(17) from /sɔsɔ/ ‘adult’

a. [sósó] ‘an adult’

b. [sósótù] ‘adulthood’

(18) from /kòob-/

[kòòbìjè] ‘kinship’

(19) from /d̪ɔ̃Nd-/

[d̪ɔ̃ndíjè] ‘age group’

(20) from /f̪ùul-/

a. [f̪ùúɾè] ‘navel’

¹⁰ This word is used in the sense it is used in Descriptive Grammars, i.e., referring to a or the class of nouns in the classification of words (Crystal 1997).

b. [tʃùùlàá] ‘small navel’

c. [tʃùùlíú] ‘big navel’

(21) from /kel-/

a. [kèlá] ‘teeth’

b. [kèlásì] ‘small teeth’

c. [kèlíŋ] ‘long teeth’

A verb root, to which a suffix usually attaches, serves as derivational base for a deverbal substantive, but in a few cases, both a prefix and a suffix attach (22). The derived substantive refers to an agent indicating the author of an action or a process ((23), (24)), an instrument involved in the accomplishment of the action expressed by the verb (25), the result of an action (26), or a state such as a quality (27). This is a productive process through which a variety of substantives are formed.

(22) From /tʃàK- / ‘sit’ , /lòl-/ ‘deliver (a baby)’, and /fèm-/ ‘awake’

a. /dì- tʃàK -jÉ/ [tʃààjé] ‘a seat’
Pref- sit -5SgT3

b. /dì- lòl -ɪ -jÉ/ [tʃlòlìjé] ‘delivery room’
Pref- deliver -EpV -5SgT3

c. /È- fèm -ìjE/ [èvèmìjè] ‘day’
Pref- wake -5SgT3

(23) Agent: from /wàb-/ ‘win’

a. /wàb -dU/ [wáɾú] ‘winner’
win - AG^1SgT1

b. /wàb -dàà/ [wáɾàà] ‘winners’
win -AG^2PIT1

(24) Agent: from /bèd-/ ‘sell’

a. /bèd -í -jU/ [pèdfjù] ‘seller’
sell - EpV - AG¹SgT1

b. /bèd -í -jàa/ [pèdfjàà] ‘sellers’
sell - EpV - AG²PIT1

(25) Instrument: from /tʃàt-/ ‘sift’ and /nàm-/ ‘heart’

a. /tʃàt -àK/ [tʃàtàá] ‘a sieve’
sift -7SgT4

b. /nàm -ÍjÈ/ [nàmíjè] ‘heart’
heart -5SgT3

(26) Result: from /sè-/ ‘benefit’ and /tʃèt-/ ‘lie’

a. /kÈ- sè -K/ [kèzèl] ‘benefit’
Pref benefit -7SgT4

b. /tʃèt -ɪ -’m/ [tʃètím] ‘a lie’
lie - EpV -10T6

(27) State: from /ki-/ ‘fat’ and /dʒé-/ ‘good’

a. /ki ki -’N/ [kíkíŋ] ‘fatness’
Pref- fat -4PIT2

b. /dʒé -Û/ [tʒéwù] ‘goodness, beauty’
good -10T6

Negative deverbal substantives are formed the same way but through an addition of one of the negation prefixes /kìr-/, /kàa-/, or /dì-/.

(28) From /jòod-/ ‘talk’

/kàa- jòod -a -’sÌ/ [kààjòòdásì] ‘speech impaired persons’
NEG- talk - EpV -7SgT4

(29) From /nàm-/ ‘respect’

/kàa- nàm -'tù/ [kàà̀nàm̀tù] ‘lack of respect’
NEG- respect -9T5

(30) From /kèd-/ ‘be good’

/kì- dì- kèd -i -'m/ [kìdìkèdím] ‘sin’
Pref- NEG- be^good -EpV -10T6

(31) From /ɕàa-/ ‘rest’

/kì- ɕà -kù/ [kìɕàkù] ‘restlessness’
NEG- sit -3SgT2

Only a few substantives do not carry affixes (compare the singular and plural examples in (32) through (34)), as noted by Lévikaza (1999: 363). They are mostly terms of kinship and borrowings.

(32) From /nèze-/

- a. /nèze -ø/ [nèzè] ‘grandmother’
grandmother -1SgT1
- b. /nèze -náà/ [nèzènáà] ‘grandmothers’
grandmother -2PIT1

(33) From /tʃàa-/ ‘father’

- a. /tʃàa -ø/ [tʃàà] ‘father’
father -1SgT1
- b. /tʃàa -náà/ [tʃàànáà] ‘fathers’
father -2PIT1

(34) From the English word *doctor*

- a. /dʒógótò -ø/ [dʒógótò] ‘doctor’
doctor -1SgT1
- b. /dʒógótò -náà/ [dʒógótónáà] ‘doctors’
doctor -2PIT1

Compounds are formed on two or more roots, to which derivational affixes also attach. Independent of the number of morphemes included (lexemes and derivational morphemes), a compound is analyzable into two main immediate constituents, the determinant and the determined. It is not uncommon therefore that one of the constituents of the compound is already complex, i.e., derived. One of the terms is determined by the other and the whole construction takes the noun suffix of the determined constituent, which is the noun (see Table 1.1 for the noun class suffixes).

The two terms of the compound can be of several different types. These include a nominal base and a substantive, as in:

(35) From /gùŋɔ-/ ‘suffering’ and /na-/ ‘see’

a. /gùŋɔ- ná -jU/ [kùŋɔ̀nájù] ‘compassionate person’
suffering- see -1SgT1

b. /gùŋɔ- ná -jàa/ [kùŋɔ̀nájàà] ‘compassionate persons’
suffering- see- 2PIT1

(36) From /kàbije/ ‘Kabiye’ and /dú/ ‘owner’

a. /kàbije dú/ [kàbìjèdú] ‘Kabiye native’
kabiye owner

b. /kàbije dú -náà/ [kàbìjèdúnáà] ‘Kabiye natives’
Kabiye owner -2PIT1

(37) From /hàl-/ ‘female, woman’ and /k̀pàK-/ ‘take’

a. /hàl- ɪ- k̀pàK -jÈ/ [hàlik̀pà́ájè] ‘marriage (of a man)’
woman- EpV take -5SgT3

One also finds a verbal base and a substantive, as in:

(38) From the roots /kìz-/ ‘refuse’ and /tòɔ-/ ‘eat’

- a. /kìz -i nè -tò -ki 'm/ [kìzi-ḡ-dòkí-m] ‘hypocritical act’
 refuse -EpV and -eat -Inacc -10T6

An adverb can compound with a substantive, as in:

- (39) From /fàlaa/ ‘free’ and /tùm-/ ‘work’

- a. /fàlaa -tùm -ÍjÈ/ [fàlààtòmíjè] ‘useless work’
 free -work -5SgT3
- b. /fàlaa -tùm -á/ [fàlààtùmá] ‘useless works’
 free -work -6PIT3

- (40) From /sàa/ ‘quick’ and /làk-/ ‘action’

- /sàa -sàa -làk -a -'sì/ [sààsààlàkásì] ‘hasty behavior’
 quick -quick -action EpV -8PIT4

We also find a nominal base an adjectival base, as in:

- (41) from /ès-/ ‘eye’ and /sém-/ ‘red’

- a. /ès í -sém -ÍjÈ/ [èsísémíjè] ‘envy’
 eye -EpV -red -5SgT3
- b. /ès í -sém -á/ [èsísémá] ‘envious actions’
 eye -EpV -red -6PIT3

- (42) From /na-/ ‘bovide’ and /hùlum-/ ‘white’

- /nà -hùlum -Ú/ [nà-hùlòm] ‘white antelope’
 bovine -white -1SgT1

Finally one observes a substantive, a postposition and another substantive:

- (43) From /èsó/ ‘God’ and /táa/ ‘in’ as in [èsódáá] ‘sky’, and /lòod-/ ‘car’

- a. /èsó -táa -lòod -ÍjÈ/ [èsódáálòòrìjè] ‘plane, aircraft’
 god -in -car -5SgT3

- b. /èsó -táa -lòòḍ -á/ [èsódáálòòḗ] ‘planes, aircrafts’
 god -in -car - 6PIT3

Like nouns, adjectives are composed of a root and affixes. Only a few adjectives in Kabiye are not derived (as exemplified by (44) – (46)) and therefore, take only the class suffix of the noun they determine. Most adjectives are derived from verb roots. Such adjectives always take also the high-toned derivational adjectival prefix *kí-* as shown in (47) – (50).

- (44) /tʃíkᵑèl -Ú/ [tʃíkᵑélú] ‘small’ as in [èjú tʃíkᵑélú] ‘small man’
 small -1SgT1
- (45) /tʃíkᵑèl -àK/ [tʃíkᵑèlàú] ‘small’ as in [háú kílèbàú] ‘small dog’
 small -7SgT4
- (46) /sòsò -tÙ / [sòsótù] ‘small’ as in [tóm sòsótù] ‘big problem’
 big -9T5
- (47) /kÍ- lèb -àK/ [kílèbàú] as in [háú kílèbàú] ‘lost dog’
 Adjr- lose -7SgT4
- (48) /kÍ- kᵑèḍ -ɪ -jÉ/ [kíkᵑèḍijé] as in [kèlím'íjé kíkᵑèḍijé] ‘black chicken’
 Adjr- black EpV -5SgT3
- (49) /kÍ- kᵑèḍ -Ú/ [kíkᵑédú] as in [èjú kíkᵑédú] ‘black man’
 Adjr -black -1SgT1
- (50) /kÍ- kᵑèḍ -àà/ [kíkᵑédàà] as in [èjáà kíkᵑédàà] ‘black men’
 Adjr- black -2PIT1

Adjectives, hence, share the same derivational suffixes with substantives; furthermore, the derivational suffix of a given adjective changes to match the derivational suffix of the noun or the substantive that the adjective describes.

The adjective, however, is not the only word class whose affixes have to match with the determined noun or substantive. While adjectives have their specific derivational prefix, which does not change, the derivational prefix of any other lexical item that refers to the noun or the substantive in a given sentence (such as subject and object pronouns and demonstratives) also matches the class prefix and suffix of the noun or the substantive. The noun class affixes and their corresponding pronouns and demonstratives are organized into a concord system.

1.3.3 Noun Classes and Concord System

Matching the affixes of the determinant items to the determined nouns or substantives gives rise to a noun concord system. Each noun class has corresponding class suffixes that identify the nouns of the class, as well as a class anaphoric prefix and suffix that serve respectively as subject and object anaphoric pronouns. In the adjective, the noun class marker (or suffix) shows the agreement of the determinant adjective with the noun that it determines. The following examples illustrate the singular noun ‘dog’ from class-7 (7SgT4) and the plural noun ‘dogs’ from class-8 (8PIT4) both of which belong to the noun type-4 as shown on Table 1.1. The class suffix and anaphoric pronouns are underlined in the following examples.

(51) [há-á sósó-á kà-né kè-véjí ná-̀]
 dog-7SgT4 big-7SgT4 7SgT4-this 7SgT4^it-be^NEG bitter-4PIT2
 ‘This big dog is not fierce.’

(52) [há-sì sósó-sì sí-lé pà- gú -sí]
 dog-8PIT4 big-8PIT4 8PIT4-those they- kill^Acc -them^8PIT4
 ‘They killed those big dogs.’

Since derivational suffixes also serve as noun class markers, the noun classes are based on suffixes and their corresponding concords. The nominal system is made of a total of 10 noun classes distributed among 6 types that Lébikaza (1999) referred to with the French “*genres*.” Following his classification, eight of these classes are grouped into four singular and plural pairs that constitute the first four types, whereas the last two classes do not have a number distinction. Table 1.1 below, adapted from (Lébikaza 1999: 369-370) summarizes the noun classes and their corresponding suffix concords markers.

Table 1.1 Noun Classes and their Concord Affixes

Types	Classes	Noun Class Suffixes	Class Anaphoric Subject Prefix pronoun	Class Anaphoric Object Suffix pronoun	Concord Demonstrative pronoun
Type-1	Singular Class-1 (1SgT1)	-ù, -ú, -ù, -ú, -jù, -jú, -jù, -jú, -ø ¹¹	è- ì-	-í	èné
	Plural Class-2 (2PlT1)	-áà, -wáà, -náà	pà-	-wé	pàné
Type-2	Singular Class-3 (3SgT2)	-kù, -kú, -kù, -kú, -ù, -ú, -ù, -ú, -ḡ, -ḡ, -ø	kì-	-kú	kùné
	Plural Class-4 (4PlT2)	-ḡ	ì-	-í	èné
Type-3	Singular Class-5 (5SgT3)	-dè, -dé, -dè, -dé, -è, -é, -è, -é, -jè, -jé, -jè, -jé	dì-	-dí	dìné
	Plural Class-6 (6PlT3)	-à, -á	à-	-á	àné
Type-4	Singular Class-7 (7SgT4)	-kà, -ká, -wá, -à, -á, -à, -á, -ḡ, -ḡ, -à, -á	kà-	-ké	kèné/ kàné
	Plural Class-8 (8PlT4)	-sì, -sí, -sì, -sí	sì-	-sí	sìné
Type-5	Class-9 (9T5)	-tù, -tù	tù-	-tú	tùné
Type-6	Class-10 (10T6)	-m̀, -ù, -ù, -wù, -wù	pù-	-pú	pùné

¹¹ A zero suffix with no underlying tone.

LébiKaza found that there was frequently a semantic motivation behind the formation of the classes, although not completely, which determines what noun belongs to what class. Accordingly he described Type-1 deverbals as the ones derived from any verb except state verbs and included nouns referring to people (e.g. [hàlú] ‘woman’, [lájú] ‘priest’), to spirits (e.g. [èsó] ‘God’, [àlèèwáà] ‘devils’), to animals ([tòm] ‘snake’, [tómáà] ‘snakes’, [héwù] ‘goat’, [héj] ‘goats’), etc. His Type-2 substantives are identified as those mostly referring to big entities whether they are animals ([tú] ‘elephant’, [nó] ‘cow’), plants ([tèlî] ‘baobab trees’) or things ([kààú] ‘rock’), as well as augmentatives. Nouns that refer to small entities such as [píuá] ‘a child’ and [kòǒǒsì] ‘flies’ fall in Type-4 corresponding singular and plural classes, which also include diminutives. Substantives that refer to a part of a whole such as [kítè] ‘forehead’ and [kílá] ‘foreheads’ are found in Type-3, whereas Type-5 and Type-6 are the realm of uncountable nouns and denote masses, collectives, and liquids as exemplified by [tétù] ‘ground’, [nánǒ] ‘meat’, and [lím] ‘water’.

1.3.4 Syllable Structure and Segmental Structure of Morpheme

The syllable structure can vary slightly from one account to another, depending on the segmental analysis proposed. The synthesized illustration that follows includes occasional modifications that reflect the view of the segmental analysis from the perspective of the current study. Based on a definition of the syllable as “a phonological unit containing a sonority peak,” nine possible syllable structures are obtained. However, like most African languages, Kabiye has the class of words referred to as

ideophones that are known to allow for indefinite lengthening of word-final vowels and nasals, which (under some views) could indefinitely increase the possible syllable structures.

The syllables occurring in the language are classified as either short or long. The short syllables, which always count one mora, are V, CV, and N¹² (a syllabic nasal).

CV is the most frequent syllable.

(53) [tú] ‘elephant’

(54) [kójê] ‘medicine’

V and N syllables occur only in prefixes.

(55) [àbàlú] ‘man’

(56) [è-vèmá] ‘he awoke’

(57) [n-lèbá] ‘You are lost’

The long syllable counts two or more morae, which can be separated by a morphological boundary. The long syllables are illustrated as follows.

VV and NN syllables occur only at word-initial as prefixes.

(58) [á-_____á- d̀̀kí] ‘Who doesn’t eat?’

Who- NEG- eat

(59) [n-_____n- l̀̀kí] ‘You cannot be lost’

you- NEG- lose

¹² A special note about nasals is in order. Nasals qualify as consonantal (C) before a vowel. Before a non-nasal consonant, they are syllabic (\bar{N}), but this will not specifically be indicated in the transcriptions in this document. Nasals in syllable coda constitute a complex nucleus with the preceding vowel. Nuclear and coda nasals, which are also TBUs, are both represented in this description simply as N.

The CVV syllable.

(60) [tòó] ‘night’

(61) [èjáà] ‘persons’

The CVVV, an unusual syllable unit cross-linguistically, is illustrate in Kabiye by words such as the following, for which there seems to be no clear reason to split the vowels in two or more syllable units.

(62) [kààú] ‘a rock’

(63) [lèáù] ‘to snatch’

CVN syllable

(64) [tòm] ‘snake’

(65) [námù] ‘respect’

The CVVN syllable

(66) [mòòh] ‘noses’

(67) [kpààh] ‘insanity’

(68) [pèèndùù] ‘to lament’

Ideophones often obey a different phonology. Due to the possibility of an indefinite lengthening at word final in ideophones, one could also have very long vowels or and very long nasals in ideophones as in [kpòòòò] ‘(Ideophone meaning) very loudly and publicly’, [èéé] or [héhé] ‘yes’, and [pìndìmm] ‘very dark’.

Some general remarks can be drawn from the syllable structures overviewed. As evidenced by these structures, consonant clusters of the type CC (i.e., a cluster in which

neither of the consonants is a syllabic nasal) are not licensed. Furthermore, distributional restrictions affect consonants in syllable coda. Only syllabic nasals are found in this position, where they constitute a complex nucleus with the preceding vowel. According to Lébikaza (1999: 177), these observations have two important consequences in the language: 1) the final consonant of a CVC- root is deleted before a suffix that begins with a consonant and 2) loan words into Kabiye that have CC clusters or end with a non-nasal consonant receive an epenthetic vowel [i] ~ [ɪ] to either split the cluster or resyllabify the final consonant. The examples in (69) to (72) illustrate loan words from French and English into Kabiye.

(69) [òtéélì] ‘hotel’ (from the French “*hôtel*” [otɛl])

(70) [mìnzíkì] ‘music’ (from the French “*musique*” [myzik])

(71) [sùkùlì] ‘school’ (from the English “school” [sku:l])

(72) [tʃóótʃì] ‘church’ (from the English “church” [tʃɜ:tʃ])

The segmental structure of morphemes and syllable structure are not always isomorphic in Kabiye. The structure of morphemes is presented next.

The work of Lébikaza (1999: 163) has shown that though every morpheme in Kabiye needs a syllabic element for its realization, the two types of morphemes found in the language (lexemes and grammatical morphemes) differ not only in the functions they assume, but in their segmental structures. Lexemes (typically, verbs) require at least one syllable with a consonantal onset and a vocalic nucleus, as illustrated in (73) through (77). A few exceptions are found in nouns as illustrated by /ɛj-/ in [ɛj-ú]

‘person’ and /ɛs-/ in [ɛs-ɔ́] ‘God’. In addition, lexemes structures can end with a consonant as exemplified by (75), (76), and (77).

(73) /dɛ ʔtù/ [tétù] ‘earth’
 ground -9T5

(74) /kapa ʔtù/ [kápátù] ‘meanness’
 mean -9T5

(75) /lèb -ù/ [lébù] ‘to lose’
 lose -INF

(76) /kel -ʔdè/ [kéɾè] ‘a tooth’
 tooth -5SgT3

(77) /tèm -ù/ [tém] ‘to finish’
 finish -INF

Lébikaza captured the structure of the grammatical morphemes in the following formula:

(C) (V) V
 N
 G

Where N represents a syllabic nasal, and G a syllabic glide

The current study follows in the steps of other earlier studies in arguing that this formula of the grammatical morphemes structure by Lébikaza needs a slight revision. According to his formula, what counts as a syllabic element includes not just a vowel and a syllabic nasal, but also a syllabic glide. In Lébikaza’s analysis, forms that illustrate the syllabic glide G in this formula are transcribed with the segments /ɣ/, /w/,

and /j/ as in /há-ỳ/ [há̀] ‘dog’, /kàà-w/ [kà̀w] ‘rock’, and /séj/ [séj] ‘grandchild’. In the works of other researchers, however, these syllable-final segments have received varied analyses. For instance, Delord (1976: 19) clearly stated that /j/ is always consonantal. On the other hand, Roberts (2002: 18), who studied verbal forms, opted to treat not only [y] as a vowel, but Roberts transcribes Lébikaza’s word-final [w] and [j] also as vowels ([u] or [ʊ] instead of [w] and [i] or [ɪ] instead of [j], depending on the vowel harmony of the word). Kassan (1996: 33, footnotes 22 and 23) also points out that [w] and [j] are not found as semi-vowels in verbs. Similarly, the current research has determined that not only [j] but also [w] are never syllabic. Instead, there are strong indications that the syllable final segments analyzed in earlier studies as /y/, /w/ and /j/ are all vowels. The analysis proposed in the current research has shown [y] not to be a segment of today’s Kabiye. In fact, the actual final segment occurring in the form for *dog* and articulated as [ɑ], is one of the various surface manifestations derived from a vocalic archiphoneme (see the analysis of vowels and the discussion on the vocalic archiphoneme in §5.1 and §5.2). Lébikaza’s /w/ and /j/, presumably occurring only after a vowel, are also analyzed in the present study as vowels, as motivated by the following three important reasons.

First, the controversial segments appearing in syllable final position undergo Vowel Harmony (or [RTR] Harmony), which strongly suggests that they are vowels. As a matter of fact, the word-final segment that is usually found as suffix or part of suffix on both nouns and verbs, and reported by Lébikaza as the glide [w], is pronounced as the [-RTR] vowel [u] on [-RTR] roots (as in [líú] ‘neck’, [sùù] ‘tail’, [kpéziù] ‘to

cough’) and as the [+RTR] vowel [u] on [+RTR] roots (as in [póù] ‘palm tree’, [láù] ‘forest’, [tâlîù] ‘to arrive’). It is further pointed out that the kind of data that earlier researchers such as Lébikaza, Delord, and Kassan transcribed with a final glide as in [líw] ‘a neck, to dip’, [níw] ‘to hear’, [tów] ‘a bow, to shoot’, [séj] ‘grandson’, [kój] ‘pick up!’, [têj] ‘(twin male name)’, etc., received two alternative transcriptions in Lébikaza 1999, the first transcription with the final glide [w] and the second transcription showing a final vowel ([u] or [û] depending on the Vowel Harmony of the word) as in [líú], [níú], [tów], [séî], [kói], [têî], respectively. As it appears, Lébikaza’s second alternative transcription supports the observation made under the current study that these final sounds can be treated as vowels.

Second, the glides [w] and [j] can be argued to occur in onset position instead, as a result of an insertion process before the Infinitive suffix /-U/. It will be demonstrated following Delord that in such verb suffixes, the final vowel is preceded by a [w] or a [j] (see Table 5.5 and Table 5.6 in §5.2.6.2), providing better grounds on which to reanalyze Lébikaza’s syllable-final [w] and [j] in such forms as sequences of [w] or [j] followed by a final high vowel. Therefore, such verbal forms in the above examples must be transcribed as [líwú] ‘to dip’, [níwú] ‘to hear’, [tówù] ‘to shoot’, and [kójí] ‘pick up!’

Last, treating these coda segments either as vowels (as suggested in the first reason) or as sequences of a glide and a vowel (as suggested in the second reason) is

more consistent with the language's known preference for the CV syllable and its strong tendency to ban consonant-like segments in coda, as just seen in the syllable structure.

Based on the differences in the current study's revised segmental analysis, which considers Lébikaza's syllable-final glides /y/, /w/ and /j/ as vowels instead, the syllable structure of Kabiye grammatical morphemes (noun affixes and aspect and tense affixes) is revised as follows:

(C)	(V)	V	
		N	<i>Where N represents a syllabic nasal</i>

In accord with this revision, an illustration of the grammatical morphemes' structures is shown as follows:

- | | | | | |
|------|-----|---------|--------|------------|
| (78) | V | [sìb | -á] | 'dead' |
| | | die | -Acc | |
| (79) | VV | [àbàl | -ââ] | 'men' |
| | | man | -2PIT1 | |
| (80) | N | [kó | -ḡ] | 'comes' |
| | | come | -Inacc | |
| (81) | CV | [nàm | -tù] | 'respect' |
| | | respect | -9T5 | |
| (82) | CVV | [jó | -jàà] | 'warriors' |
| | | war | -2PIT1 | |

1.4 Conclusion

This chapter has presented the historical, geographic, and linguistic background of Kabiye, and given a general overview of the literature found on this language. The available linguistic descriptions have started to explain its morphology, syntax, phonology, and semantics. These descriptions have contributed much to the understanding of the grammar of the language. However, this chapter has also hinted at some general issues in the existing phonological studies that need improvement, thus motivating the present research.

Previous phonological descriptions are controversial due not only to methodological issues, but also to noticeable discrepancies in their findings, which will be pinpointed in the exclusive detailed review of this literature in the next chapter.

CHAPTER 2

REVIEW OF PREVIOUS SEGMENTAL PHONOLOGY AND TONE ANALYSES

2.1 Introduction

The motivation of this research developed from both what is found and what is lacking in the existing tone analyses and segmental descriptions of Kabiye. From the overview of the literature in the preceding chapter, it is clear that segmental phonology and tone analyses have been treated in only a handful of the linguistic works on the language. However, because the phonological treatments are of particular interest to the present study, it is important that this specific literature be reviewed more thoroughly.

As will be shown, these early phonological analyses have importantly laid the foundation of Kabiye study, but need revision at various levels in light of new insights into the language, as proposed in the present research. Before going into the revisions, a thorough review of these analyses is presented in order to show the state of the phonological research on this language. A subsequent assessment of these studies will show their strengths and weaknesses.

2.2 Review and Assessment of the Segmental Phonology

The fundamental accounts of segments come from Delord (1976) and Lébikaza (1985, 1999), but other studies have also contributed to Kabiye phonology. Indeed, only

some of the subsequent researchers have adopted the segmental analyses of their predecessors, but not without revisions. As a matter of fact, Kassan (1996) adopted the inventory of Lébikaza with only minor classificatory changes for the consonants, but none of Paaluki (1995), the CLNK & SIL-Togo (1998), or Roberts (2002) agreed with the studies before them and, therefore, presented their own inventories.

In considering all these descriptions, there is a broad sense of agreement on most of the segmental phonology, but also noteworthy disagreements that range from initial phonetic details about the segments to the phonological inventories through the phonological rules that connect both levels.

2.2.1 Previous Analyses of Vowels

Although various scholars have posited different accounts of the underlying system of Kabiye vowels, only one researcher, Lébikaza, presents a *phonetic* vowel inventory (Table 2.1).

Table 2.1 Phonetic Chart of Kabiye Vocalic Sounds (Lébikaza 1999: 39)¹³

	FRONT	BACK
HIGH	i y ɪ ʏ	ɯ u ɯ ʊ
MID	e ø ɛ œ	ɤ o ʌ ɔ
LOW	a	ɑ

¹³In this dissertation, IPA standards have been adopted. Hence, some of the sounds, as transcribed in the work of Lébikaza, have been changed to fit the IPA. For instance, y = ü; ɪ = ɿ, ... (etc.).

The inventory in Table 2.1 also received the classification in Table 2.2.

Table 2.2 Phonetic Classification of Vowels (Lébikaza 1999: 42)¹⁴

[+ATR] Vowels				[-ATR] Vowels			
	FRONT		BACK			BACK	
HIGH	i	y	ɥ	u	ɤ	ɯ	ʊ
MID	e	ø	ɣ	o	ɛ	œ	ʌ
LOW					a	ɑ	

Lébikaza also reports combinations of the short vocoids into long vowels, extra long vowels, and diphthongs. The vocoids occur in three quantities: short as [i] in [tím̀] ‘to cut down’, long as [ii] in [liì] ‘dip!’, and extra long as [iii] in [kiiì] ‘ideophone intensifying the idea of turning around’(Lébikaza 1999: 42).

Two sets of diphthongs are shown in the works of Lébikaza; the first type of diphthongs glide from an unrounded front vowel to an unrounded back vowel (Figure 2.1).

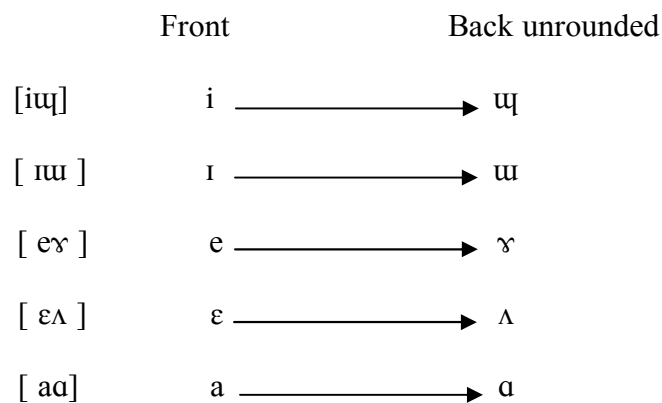

Figure 2.1 First type of diphthongs (Lébikaza 1999: 43)

¹⁴ The author may have accidentally omitted the high front unrounded vowel [ɪ], which is missing from the table.

The second type of diphthongs, which glide from a rounded non-high back vowel or an unrounded front vowel to a rounded high back vowel (Figure 2.2), are shown as [iu, ɪʊ, eu, εʊ, ou, ɔʊ, aʊ].

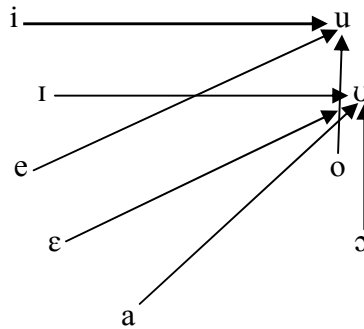

Figure 2.2 Second type of diphthongs (Lévikaza 1999: 44)

Irrespective of what their beginning phonetic inventory might have been, all the studies (Delord 1976, Lévikaza 1985, 1999, Kassan 1996, Paaluki 1995, CLNK & SIL-Togo 1998, Roberts 2002, 2003) agree on the first nine basic (or short) vocalic phonemes as summarized in Table 2.3. The vowels are arranged in two almost symmetrical sets that contrast with regard to the feature [ATR] (Advanced Tongue Root), a contrast in which the single low vowel /a/ does not partake.

Table 2.3 Basic Vocalic Phonemes Found in all Previous Studies

	FRONT	BACK
	+ATR/ - ATR	+ATR/ - ATR
HIGH	i / ɪ	u / ʊ
MID	e / ε	o / ɔ
LOW		a

Only minor classificatory details about the short or basic vowels distinguish the views of the authors. In the classification presented by Roberts and the CLNK & SIL-Togo, /a/ is treated as a neutral vowel with respect to [ATR] specification (i.e., neither [+ATR] nor [-ATR], as shown in Table 2.3). The classifications of Delord and Lébikaza, however, categorize /a/ with the [-ATR] set of vowels. Moreover, Roberts (2002: 9) refers to the vowel height as Close, ½ Open, and Open, instead of their labels in Table 2.3 as High, Mid, and Low, respectively. The vowels table presented by Paaluki (1995: 16) does not show any classificatory labels, though he also show the [+ATR] and [-ATR] sets of vowels separately and the vowel /a/ on its own.

In addition to the nine basic vowels, further vocalic phonemes were presented in Roberts 2002 and CLNK & SIL-Togo 1998, namely their “long vowels” and “long pharyngealized vowels.” Both works transcribe the long vowels by doubling short vowels (Table 2.4), and they transcribe the long pharyngealized vowels by combining a short front vowel with the symbol [ɣ]¹⁵ (Table 2.5).

¹⁵ This symbol represents a voiced velar fricative in Delord’s (1976) description, a velar glide in Lébikaza’s (1999: 88), but a “graphic representation” of the “orthographical symbol ɣ” in Roberts’ (2002: 11) notation.

Table 2.4 The Long Vocalic Phonemes According to Roberts and CLNK & SIL-Togo

	- Back		Central	+ Back	
	+ ATR	- ATR		+ ATR	- ATR
Close	ii	ɪɪ		uu	ʊʊ
½ open	ee	ɛɛ		oo	ɔɔ
Open			aa		

Table 2.5 Long Pharyngealized Vocalic Phonemes According to Roberts¹⁶ and CLNK & SIL-Togo

	- Back		Central
	iɣ	ɪɣ	
Close	iɣ	ɪɣ	
½ open	eɣ	ɛɣ	
Open			aɣ

Some minor differences are noted in the actual classifications that appear in the studies. The vowels in Table 2.4 and Table 2.5 are those listed in the works of Roberts and CLNK & SIL-Togo, but the classification shown is that of Roberts (2002). CLNK & SIL-Togo 1998 groups the vowels in three columns, labeled as Basic Vowels, Long Vowels, and Pharyngealized Vowels, but shows vowel height in five unlabeled rows. However, the remainder of the analysis of vowels is identical in both studies. Besides, it must be stressed that unlike CLNK & SIL-Togo 1998, the segmental analysis of Roberts

¹⁶ In Roberts (2003: 10), the long pharyngealized vowels are also called the long unrounded dorsal vowels and transcribed as: [u:] (for [iɣ]), [ʊ:] (for [ɪɣ]), [ɛ:] (for [eɣ]), [ɔ:] (for [ɛɣ]), and [ɑ:] (for [aɣ]).

(2002, 2003) does not include /y/ as a phoneme of Kabiye. In fact, among the previous studies, Roberts only shares this view with Paaluki 1995. In Roberts' work, however, the "graphic representation of this sound" is "the orthographical symbol y" (Roberts 2002: 11). Later in Roberts' Post Master's (DEA) thesis, he also referred to the long pharyngealized vowels as the long unrounded dorsal vowels¹⁷ and specified that they were not phonemes *per se* (Roberts 2003: 10).

Three different vocalic phoneme inventories emerge thus from the literature: 1) nine vowels (Delord 1976, Lébikaza 1985, 1999, Paaluki 1995, Kassan 1996), 2) 23 vowels (CLNK & SIL-Togo 1998, Roberts 2002), and 3) fewer than 23 vowels but greater than nine (Roberts 2003). Yet, one would expect the inventories of phonemes to be consistent, given especially that the defined variety of Kabiye that is analyzed in all the studies is exactly the same. The following questions, therefore, arise: Why, then, are there divergent views in previous accounts? Which account is the most descriptively adequate?

Faced with an important divergence in the outcome of the studies, no one of the vocalic inventories can be adopted without an evaluation of all the studies.

2.2.2 Assessment of the Analyses of Vowels

Each of the studies reviewed here are assessed to bring out their strengths and weaknesses, with the relevant criteria being details of the analysis, accuracy of the information, and groundedness of the argumentation.

¹⁷ Our translation of the French "Voyelles longues dorsales non-arrondies."

A comparative examination of the argumentation and details given by the studies may help decide which among these segmental analyses is grounded. Of all the works that present the segmental phonology of Kabiye, only Delord 1976 and Lébikaza 1985, 1999 provide a linguistic analysis *per se*. Hence, these studies show the argumentation that underlies their analyses. Lébikaza's phonological analysis is the most detailed, showing the steps of the analysis, as well as surface and underlying segments. Delord's work is limited in details and does not provide any phonetic inventory of segments; instead, his phonological analysis illustrates only contrastive segments. In contrast, the phonologies found in Paaluki 1995, CLNK & SIL-Togo 1998, and in Roberts' (2002, 2003) works simply list the phonemes in tables with little to no details as to how the authors reached their results. Not showing a thorough analysis makes questionable the results in the latter works. It is noted that this very issue has also concerned Roberts himself (Roberts 2002) about the phonology in the dictionary of CLNK & SIL-Togo (the authorship of which he mistakenly attributes to Marmor; see Marmor ed. in Roberts 2002 bibliographic references) and led him to question their results. It is pointed out about the works of Paaluki and CLNK & SIL-Togo, though, that they are only intended as phonological summaries, not phonological descriptions. Indeed, it must be noticed following Roberts (2002) that the phonology in the introduction to the dictionary of CLNK & SIL-Togo 1998 (and likewise the one in the introduction to the Glossary of Paaluki 1995) are only summaries aimed at the public at large. A similar remark can apply to the segmental phonology found in Roberts' (2002, 2003) own works; it is

meant as a quick summary to help the reader follow Roberts' intended research, which is about the tone classes of verbs and the tones of modality prefixes. However, though such an argument may explain why the steps of the analysis are not made explicit in the latter works, it does not make up for their lack of detail as a weakness.

The other criteria by which the works are assessed relate to how accurate and grounded their details and arguments are. Of the studies that show details and argumentation, it can be said about the analysis in Delord 1976, which shows only contrasts between phonemes, that there is no way of determining if Delord posited any wrong allophone as phoneme. However, since Delord's phonemes are identical to those identified by Lébikaza's detailed analysis, Delord's inventory will be legitimated if the accuracy of Lébikaza's analysis is established. For the works of Paaluki, CLNK & SIL-Togo, and Roberts, which do not offer details and argumentation, suffice it to say that it is difficult to fully assess them.

The strength of the phonological analysis presented by Lébikaza 1999 lies in the insightfulness of the argumentation and the facts presented. Lébikaza's phonetic inventory includes a large number of vocoids, all of which are illustrated and fully described, and from which he later determines the vocalic phonemes. It shows the short vowels phones [i ɪ y ʏ e ε ø œ ɥ ɯ u ʊ ɤ ʌ o ɔ ɑ a], nine of which appear in the results of the other researchers. His phonetic inventory also acknowledges the long vowels also included in the results of the other researchers. In addition to these, Lébikaza's inventory includes extra long vowels and two sets of diphthongs. His first type of

diphthongs, [iɥ iʊ eɣ εʌ aɔ], appear to correspond to the long pharyngealized phonemes /iɣ iʏ eɣ εɣ aɣ/ of Roberts (2002) and CLNK & SIL-Togo (1998), also acknowledged by Paaluki (1995) who, however, does not explicitly refer to them as phonemes. Lébikaza's second type of diphthongs and his extra long vowels are not mentioned in the work of any other researcher.

Through minimal pairs, contrasts, and a study of the environments in which the vocoids occur, Lébikaza determines the phonological status of nine short vowels, /i ɪ e ε a o ɔ u ʊ/, which are the same as the ones determined by Delord and on which all the studies also agree. Lébikaza analyzes the extra long vocoids, occurring mainly in ideophones, as manifestations of the nine short vocalic phonemes through a lengthening process (extra long vowels can be lengthened indefinitely) and dismisses them from the phonological system. For the remaining vocoids not appearing in his phonological system, he shows that the two morae in the long vocoids and the diphthongs can belong to different morphemes, the first mora to the root of the word and the second, to the suffix. As a matter of fact, the second [a] of the long vowel [aa] in a form such as [tòwà-á] 'ate' represents the morpheme of the Accomplished aspect. Moreover, [u] and [ʊ], which are the second vowels in the diphthongs [iʊ iʏ eʊ εʊ aʊ oʊ ɔʊ], are the suffixes morphemes of the Infinitive in forms such as [sètí-ù] 'to cut' and [k̀pèzí-ù] 'to cough', [tòù] 'to spit', and so forth. Similarly, [ɥ ʊ ɣ ʌ ɔ], which can only be found as the second element of the diphthongs [iɥ iʏ eɣ εʌ aɔ], respectively, occur also as actual forms of the morpheme of the Inaccomplished as in [è-zétí-ú] 'he cuts', [è-ḡbézi-

ú] ‘he coughs’, [è-bá-à] ‘he dances’, and so forth. The second element of the diphthong [aɔ], is also found as a noun suffix, as in [há-à] ‘dog’ (cf. [há-sì] ‘dogs’). Furthermore, through an opposition in the second mora of forms that are near-minimal pairs, Lébikaza establishes a partial contrast of the second elements in the diphthongs [iɔ iu eɣ ελ aɔ] to the second vowel in the long vowels [ii ɪ ee εε aa]. Based on this partial contrast and the intervening morphological boundary between the morae of the long vowels and the diphthongs, Lébikaza considers them as arising phonetically from the co-appearance of two different vocalic phonemes (which he refers to with the French, “*biphonématiques*”): a long vowel is phonologically two of the established basic or short vocalic phonemes occurring next to each other that only happen to be identical. A diphthong, on the other hand, is phonologically constituted of two non-identical phonemes: while the second type of diphthong [iu iu eu εu ou ou au] are combinations of basic vocalic phonemes, the first type of diphthongs [iɔ iu eɣ ελ aɔ] combine each a basic vocalic phoneme and another phoneme. Later, Lébikaza derives the unrounded back vocoids [ɔ ɪ ɣ λ ɑ], second elements in the first type of diphthongs, from a single phonological segment with a particular status, which is listed as the semi-vowel “/ɣ/” (Lébikaza 1999: 42-56)¹⁸. It follows from the phonological analysis of Lébikaza that none of the diphthongs, the long vowels, and the extra long vowels is attested in the underlying representation of Kabiye vowels.

¹⁸ A further discussion of this “phoneme /ɣ/” from the perspective of the present research is included in the revised in Chapter 5.

Beyond the insightfulness of the new analysis presented in Lébikaza 1999, however, lie some weaknesses, some of which ultimately have implications on the resulting vocalic system of his analysis. These have to do with an incompleteness of the phonetic inventory, the phonological analysis of the long vowels, and the nature of his semi-vowel /y/. It is determined that a third series of diphthongs is lacking in the phonetic inventory of Lébikaza 1999. The diphthongs in this series appear to glide from a rounded back vowel or an unrounded front vowel toward an unrounded high front vowel; illustration of these diphthongs include [ɛɪ] in [tɛ́ɪ] ‘male proper name’, [aɪ] in [kɔ́pá-ɪ] ‘catch him!’, [oi] in [kóí] ‘interjection of disagreement’. In his phonological analysis, despite the existence of minimal pairs contrasting long vocoids with short ones, Lébikaza founded his argumentation on a morphological boundary that intervenes sometimes between the vocoids to decide that they are constituted of two separate vocalic phonemes. It is noted, however, that though a morphological boundary may always separate the diphthongs, not all long vowels occurring in the language can be shown to include such a morphological boundary. This seems to be specifically the case of long vocoids occurring in word roots, which always manifest themselves as long (viz. [kóó-jé] ‘water pot’, [tòòvèní̀m] ‘truth’ [tè̀èb-íjè] ‘sauce pan’). In addition, short and long vocoids crucially appear to differentiate between examples such as [lì] ‘swallow!’ vs. [lì̀] ‘dip!’, [lò] ‘wrestle!’ vs. [lò̀] ‘weave!’, and [tè] ‘sustain!’ vs. [tè̀] ‘sing!’ Contrary to Lébikaza’s determinations, it is concluded from these facts that vowel length is contrastive, a conclusion that supports the long vocalic phonemes in the

findings of Roberts (2002, 2003) and CLNK & SIL-Togo (1998). With respect to diphthongs, for which Lébikaza eloquently establishes near-minimal pair contrasts with the long vocoids, it is noted about his first type of diphthongs that the phonological segment “/ɣ/,” from which he derives the second constituents in his first type of diphthongs (i.e., the unrounded back vocoids [ɯ ɯ ɤ ʌ ɑ]), is a questionable (or marginal) segment of Kabiye.

In sum, analyses of the vocalic systems found in previous studies, including the one presented by Lébikaza, are unsatisfactory. They include too few or too many segments. Lébikaza’s (1985, 1999) vocalic analysis makes an important contribution to the vocalic phonology of Kabiye by offering many details and insights that no other author mentions, but his analysis also misses some no less important conclusions. Many points in Lébikaza’s analysis are insightful and supported with facts, proving good grounds for nearly all the segments included in his phonetic and phonological inventories. But, both inventories are determined to be incomplete, lacking other segments that needed to be included. The same conclusion applies to the vocalic system in Delord 1976 and Paaluki 1995, both of which are identical to the vocalic system of Lébikaza. On the other hand, while it is concluded from this assessment that the long vocalic phonemes listed in the findings of Roberts (2002, 2003) and CLNK & SIL-Togo (1998) are well grounded, the vocalic system found in the latter studies cannot be entirely legitimated, because of the extra phonemes that they also include, namely their long pharyngealized vowels. Lébikaza’s analysis has well shown that these so-called

long pharyngealized vowels, which correspond to his first type of diphthongs, are only manifested at the phonetic level. Underlyingly, the constituents in these diphthongs represent two different phonemes; the first constituent always represents one of the nine short vocalic phonemes and all the second constituents represent a single underlying segment, the true nature of which Lébikaza did not successfully pinpoint. Ultimately, therefore, none of the vocalic systems found in all previous studies is entirely grounded and satisfactory; a revisit of the vocalic analysis is necessary.

2.2.3 Previous Analyses of Consonants

As was the case with the vocalic studies reviewed above, the consonantal analyses appearing in the literature also demonstrate important differences in the specific consonants inventoried as well as in the classification of these segments.

The consonant inventories provided in three of the studies (Delord 1976, Lébikaza 1999, and Roberts 2002) include a total of 18 consonant phonemes, while the inventory of Paaluki includes 24 consonants and that of CLNK & SIL-Togo, 25 consonants. With regard to classification, Lébikaza's work also shows the most detail, compared to others. The consonants inventories proposed by these authors appear in Table 2.6 through Table 2.11¹⁹.

¹⁹ Some of the symbols in these reproduced tables have been adapted to IPA notation.

Although Lébikaza provides only a phonetic classification of the sounds, but not one for phonemes, his sounds are reported here in a as Table 2.8, adapted from his phonetic classification table.

Table 2.6 Consonant Phonemes According to Delord (1976: 23)

	Voiceless (becoming voiced in intervocalic)		Voiced	
	Stops	Continuants		nasals
Bilabials	b	f		m
Dentals	t	s	z	n
Retroflexes	ɖ		ɭ	
Palatals	tʃ		j	ɲ
Velars	k		ɣ	ŋ
Velo-Labials	k̠p̠		w	
Pharyngeal			h	

Table 2.7 Consonant Phonemes by CLNK & SIL-Togo (1998, p.1 of Esquisse...)

	front part of the mouth				back part of the mouth					
Voiceless	p	f	s	t		tʃ	k	k̠p̠		
Voiced	b	v	z	d	ɖ	ɖʒ	g	g̠b̠	ɣ	
					r					
Nasal	m		n			ɲ	ŋ			
Voiced	w		l			j	h			

Table 2.8 Consonant Phonemes According to Lébikaza (1985, 1999)

	Bilabial	Labio-Dental	Dental-Alveolar	Retroflex	Alveo-Palatal	Palatal	Velar	Labial-Velar	Glottal
Stops	p		d t	ʈ			k	ᵑ	
Fricative		f	z s						
Affricate					tʃ				
Nasal	m		n			ɲ			
Liquid			l						
Glide						j	ɣ	w	
Approximant									h

Table 2.9 Consonant Phonemes According to Paaluki (1995: 17)

		Labials	Labio-Dentals	Apico-alveolars	Retroflex	Palatals	Velars	Labial-velars	Laryngeals
Stops	Voiceless	p		d	ʈ		k	ᵑ	
	Voiced	b		t	ɖ		g	ᵑb	
Fricatives	Voiceless		f	s		tʃ			
	Voiced		v	z		ʒ			h
Nasal	Voiced	m		n		ɲ	ŋ		
Vibrants	Voiceless					r			
Semi-vowels	Voiced	w				j			

Table 2.10 Inventory of Consonant Phonemes According to Roberts (2002, 2003)

		Labial	Labio-dental	Dental	Retroflex	Alveo-palatal	Palatal	Velar	Labial-velar	glottal
+ obstruents	vl	p	f	t	ʈ	s	tʃ	k	kp̄	
	vd			d		z				
- obstruents		w		l			j			h
+ nasals		m		n			ɲ	ŋ		

In addition to these tables, a new classification table (Table 2.11) is also proposed in Kassan's (1996) dissertation for Lébikaza's (1985) consonant inventory.

Table 2.11 Kabiye Consonant Phonemes' Classification by Kassan (1996: 22)²⁰

	Bilab	Lab Dent	Dent	Retr	Dorso -alv	Palat	Vel	Post-vel
Bruy	p	f	t d	ʈ	s z	tʃ	k ɣ	kp̄
Nas	m		n			ɲ		
Non-bruy	w		l			j		h

The details of these consonant tables diverge in noticeable ways that relate to the specific segments chosen as well as their classification and labels. With respect to the phonological segments, the first five tables agree on most of the sounds but not all. The

²⁰ The labels "Bruy" (for "bruyants"), "Non-bruy" (for "non-bruyants"), and "Nas" (for "nasales"), are the French words for buzzing, non-buzzing, and nasals, respectively.

biggest difference comes from Paaluki's inventory (Table 2.9), which displays a fuller series of obstruents, which contrast in voicing, except the laryngeal fricative. Furthermore, Table 2.9 very strikingly includes a "vibrant palatal" /r/, which is also encountered only in the CLNK & SIL-Togo's inventory, with apparently a different classification (Table 2.7), and lacks the lateral segment /l/ that is found in all the other tables. The consonant phonemes inventory proposed by Roberts (Table 2.10) widely resembles that of Lébikaza (Table 2.8) but it also differs from it on a couple of points. Roberts' inventory includes all the sounds in the inventory of Lébikaza except two: on the one hand, Roberts' inventory rejects the /ɣ/ of Lébikaza (and Delord, Table 2.6), as does Paaluki (Table 2.9); on the other hand, Roberts re-establishes the phonological status of the velar nasal /ŋ/ from the prior work of Delord, which Lébikaza subsequently dismissed. Roberts' table (Table 2.10) and the one of Lébikaza (Table 2.8) agree on the remaining consonant. Particularly, these tables include the voiced /d/ and the voiceless /p/ and /t/ as phonemes, instead of their respective counterparts /t/, /b/ and /d/ advocated by Delord (Table 2.6). Kassan (Table 2.11) adopts the consonant inventory from Lébikaza (Table 2.8) to which she applies a new classification. Therefore, Kassan agrees with Lébikaza on all of the consonants. Consequently, everything that is stated about the choice of consonants in Lébikaza's table (Table 2.8) also applies to Kassan's table (Table 2.11).

The most important divergences displayed in the classification of consonants in all six tables relate to how they address place of articulation. All the tables use similar

classificatory labels but group the consonants in slightly different ways, except for Table 2.7 of the CLNK & SIL-Togo, which does not show individual labels for the subclasses of sounds in this category. The biggest shift, though, lies in the subclasses under which some of the consonants fall across tables. For instance, /f/ appears as a bilabial sound in the classification of Delord (Table 2.6) as opposed to its classification as a labio-dental consonant by the other authors (Table 2.8, Table 2.9, Table 2.10, and Table 2.11). Likewise, /l/ is found to be a retroflex sound in Table 2.6, but it constitutes a class together with the dental or dental-alveolar consonants in Table 2.8, Table 2.7, Table 2.10 and Table 2.11; moreover, Paaluki's table (Table 2.9) does not include /l/ at all. Similarly, /h/ forms a class with the velar consonant in Table 2.7, whereas it is classified as a post-velar consonant and analogously as "pharyngeal," "laryngeal," or "glottal" in other classifications (Table 2.6, Table 2.8, Table 2.9, Table 2.10, and Table 2.11). In another respect, although Delord does not show a phonetic inventory of consonants, he provides a brief discussion of some particular realizations of consonants. In this discussion, a noteworthy difference is also found, which relates to Delord's "dentalized bilabial" [ɸ] discussed as a phonetic realization of his bilabial /f/ (Delord 1976: 19). Yet Lébikaza points out that Delord's "dentalized bilabial" fricative was never found. Another shift in the classification of consonants by place of articulation involves Roberts' phonemes /s/ and /z/ identified as alveo-palatals (Table 2.10), but as dental-alveolars in Lébikaza's classification (Table 2.8). Kassar's classification of consonants by place of articulation also departs from that of Lébikaza in some

noticeable ways. For example, Kassan splits the dental-alveolar consonants of Lébikaza (Table 2.8) into two distinct classes as dental, including /d t n l/, and as dorso-alveolar, which includes /s z/ (Table 2.11). She also merges Lébikaza's labial-velar and glottal classes of into a single new class that she calls post-velar. Lébikaza's labial-velar /w/, however, is no longer part of the new class in Table 2.11; instead, it is moved forward into a purely bilabial class. Similarly, the purely palatal consonant and the alveo-palatals consonants of Lébikaza now share a single palatal point of articulation class in Kassan's new classification (Table 2.11).

With respect to manner of articulation especially, two tendencies are observed in the way the tables classify the sounds. The classifications of Delord (Table 2.6), Roberts (Table 2.10), Kassan (Table 2.11), and to some extent the CLNK & SIL-Togo (Table 2.7, all show consonants in fewer classes with similar labels. They distinguish between only three main classes: stops in Table 2.6 (“+obstruents” in Table 2.10 and analogous to “bruy” in Table 2.11), continuants in Table 2.6 (analogous to “-obstruents” in Table 2.10 and to “non-bruy” in Table 2.11) and nasals in Table 2.6 and Table 2.11 (“+nasals” in Table 2.10). Table 2.9 and Table 2.10 also classify the sounds by voicing, as does Table 2.7 of the CLNK & SIL-Togo. Kassan (Table 2.11) thus strikingly merges the six manner of articulation classes of consonants in Lébikaza's table (Table 2.8) into three subclasses only as “bruyants,” “nasales,” and “non-bruyants.” In contrast, the classification by manner of articulation adopted by Lébikaza (Table 2.8) and Paaluki (Table 2.9) is far more detail-oriented, with more subclasses for

the consonants and also similar labels. Both tables, however, are differentiated by two noticeable things: Table 2.9 adds a subclass of “vibrants” where Table 2.8 has “liquids”; Table 2.9 also merges the affricates and fricatives of Table 2.8 into a single class referred to as fricatives. For all the tables in general, another important divergence is also noted in the classes under which some of the consonants fall. Most noticeable in this case is /y/, which constitutes a class with stops in Table 2.7, but is shown as a continuant in Table 2.6 and Table 2.11, or as an approximant in Table 2.8. It is further noted that Table 2.9 and Table 2.10 do not include this phoneme.

As this cross comparison reveals, the state of the segmental phonology of Kabiye remains an open topic. Although there is a wide agreement on a solid common core of consonants, there is disagreement with respect to various details. More disturbing is the fact that with each new inventory of phonemes proposed, there is either dismissal of some segments or addition of new segments. In this state of contradictory analyses, the first step toward identifying the most reasonable among the studies is to examine the proposed analyses for the basis on which each of them is grounded.

2.2.4 Assessment of the Analyses of Consonants

In evaluating the studies at hand, the individual analyses show various strengths and weaknesses. For the overall classification of the consonants in the six tables, it can be stated that only the way consonants are grouped differ; four of the tables do so in one way and the other two tables, in another. But the more detail-oriented classifications of the sounds provided by Lébikaza (Table 2.8) and by the CLNK & SIL-Togo (Table

2.9) have the advantage of providing the subclasses of sounds with labels that are more specific than the general labels used by the other researchers. Indeed, the most obvious point of strength of Lébikaza's consonants analysis is its detailed and step-by-step developments. Every consonantal realization of the language is first inventoried, then given consideration in the phonological analysis from which the phonemes emerge. The lack of such a procedure and scant details in the analyses of Roberts and CLNK & SIL-Togo puts their phonological inventories at a disadvantage, though these results cannot be simplistically dismissed on these grounds.

However, it is worth pointing out some potentially troubling facts about some of the consonant phonemes in all the tables of the studies, generally considered. In Delord's system (Table 2.6), for example, it is apparent that there is either a misclassification of the sound /f/ as a bilabial consonant or an inappropriate choice of the symbol to represent the consonant. Phonetic conventions demand that the sound represented by the symbol /f/ have a labio-dental point of articulation, as appearing in the classification tables of the other researchers. A similar observation is made for /tʃ/ and /dʒ/ referred to as fricatives by Paaluki (Table 2.9); both palatals are known as affricates in IPA conventions. Chronologically, it is also observed an inconsistency across the studies in the choice of some phonemes. Particularly, /ŋ/, /ɣ/, and /l/ are initially posited as phonological segments in Delord's study (Table 2.6); in Lébikaza's subsequent inventory (1985), /ŋ/ as phoneme is rejected (Table 2.8), as it would again be in Lébikaza's later work (1999). On the other hand, Paaluki 1995, which followed

Lébikaza 1985, reintroduced /ŋ/, but rejects /ɣ/, and /l/, all of which reappeared subsequently in CLNK & SIL-Togo 1998 (Table 2.7), though their status as earlier redefined in Lébikaza 1985 got reinstated in Kassan 1996 (Table 2.11). In the most recent studies by Roberts (2002, 2003), /ŋ/ and /l/ are kept as phonemes of Kabiye, but /ɣ/ is questioned again. Similar to this case is that of /r/, which was not shown in the first studies by Delord and Lébikaza (Table 2.6 and Table 2.8), but appeared in the inventories proposed by Paaluki and CLNK & SIL-Togo (Table 2.9 and Table 2.7), only to be subsequently rejected by Roberts (Table 2.10).

Considering the phonological segments in the tables, another observation is concerning: some inventories exhibit mostly voiceless obstruents with only a few that are voiced (Table 2.6, Table 2.8, Table 2.10, and Table 2.11), yet these tables disagree on exactly what these “defective” voiced obstruents should be. Other inventories include fuller sets of obstruents that include pairs of voiced and voiceless segments. For Paaluki (Table 2.9), especially, there is almost an equal number of voiced and voiceless obstruents, except for the laryngeal fricative /h/. The same observation is made of the obstruents in the table of CLNK & SIL-Togo (Table 2.7), which makes exception for /d/ and /ɣ/, instead. The direct consequence of this important difference in the obstruents inventories is a significantly larger number of consonants in the latter tables (Table 2.9, Table 2.7) than in the earlier ones, producing an irreconcilable discrepancy in the size of the inventories, as well as in the specific consonants included.

Considering the strengths and the weaknesses of the studies from the perspective of an outsider who does not have any other data than shown in the studies (and hence, not necessarily all the facts of the language) and relies only on what is presented in the studies themselves, it is simply impossible to determine with certainty the results of which study capture the right generalizations and which fail to do so. Except for the studies by Lébikaza, none of the other studies can be fully evaluated, since the motivation of their choices is left unreported. On the one hand, when the studies are compared, Lébikaza studies seem to have motivated his analysis and his results. On the other hand, though, it cannot be ignored that how grounded Lébikaza's analysis is also depends crucially on consideration of all the facts about the segments. Questions therefore still remain, the answers to which lie far beyond consideration of the studies themselves: How can it be known if Lébikaza presented a complete account of the facts or not? Could Lébikaza have missed something? Considering the irreconcilable discrepancies among the tables, especially, is it possible that there are some overlooked features of the language, which Lébikaza's analysis did not present, and that might have informed the decisions of the other studies? Answers can neither be found in the studies themselves nor can they be brought to light through the only examination of Lébikaza's analysis, as in this review. It only helps to know the data to fully evaluate the exhaustiveness of Lébikaza's segmental analysis. In fact, acquaintance with the data of the language indicates that Lébikaza's consonants analysis is overly parsimonious (to the point of inaccurate) and does not take into consideration some crucial data, which go counter his analysis of obstruents particularly. Indeed, in positing only voiceless

obstruents (beside /t/ and /s/, for which minimal pairs contrast each voiceless consonant to its voiced counterpart /d/ and /z/, respectively), Lébikaza's generalization leaves out another observed fact about the behavior of obstruents in this language: that obstruents occurring in medial positions are *not* always voiced. This fact forces one to seriously question an account whereby the voiced counterparts of underlyingly voiceless obstruents would be derived by a medial-position voicing process, as in Lébikaza's analysis (1999: 94-161). This point appears to support the consonants inventories that list extensive contrasting voiced and voiceless obstruents. It is also argued that the phoneme /ɣ/ defined in Lébikaza's studies as a velar glide (but a velar fricative in Delord 1976), and which is questioned and rejected by Roberts (2002, 2003) and Paaluki (1995), may not be a fully-fledged phoneme of Kabiye. This back-and-forth observed over time across the studies about this /ɣ/ and some other phonemes also adds to the ambiguity of the inventories and cautions against the choice of any one study over the others. Moreover, these latter studies, despite their lack of detail, appear to include important but unstated arguments regarding the language's phonological inventory.

In light of the discussion in the assessment of consonants and vowels, it is concluded that although many of the segments reported by the studies are unequivocally grounded, many others are not so. From the phonetic to the phonological inventories, segments are left out of the analyses, crucial pieces of information regarding some segments and generalizations are missed. Segments included in some inventories and their classifications are clearly inadequate and questionable. Therefore, without

undertaking a phonological reanalysis, no one inventory can be singled out as meeting descriptive accuracy. A thorough phonological reanalysis is needed, one that builds on the insights from previous studies, while endeavoring to consider facts completely in order to include information that Lébikaza's studies have overlooked, draw better generalizations, and determine if there are grounds for any of the inventories of segments presented in all former studies.

Beside vowels and consonants, tone has also received attention in the phonological analyses by the researchers. Tonal phonology is reviewed next.

2.3 Review of the Literature on Tone

Initial accounts of Kabiye tone are provided by Delord and Lébikaza, who paved the road for subsequent work. Later tone analyses further received significant impetus from more research by Lébikaza and other researchers. This body of tone literature covers a variety of topics.

Among the studies that focused on the fundamentals of tone, one first notes works by Delord (1968, 1976) and Lébikaza (1985, 1999), which discuss tone inventory, the distinctive features of tone, underlying tonal melodies for morphemes, and a variety of tone rules that explain observed patterns of surface tones. They further focused on determining and explaining some aspects in the word and larger domains. Tone inventory was also shown in the introduction to the glossary of Paaluki (1995) and in the introduction to the bilingual dictionary of the CLNK & SIL-Togo (1998). The dissertation of Kassan (1996) and the theses of Roberts (2002, 2003) also provide noteworthy discussions of some of the fundamentals of tone that Delord and Lébikaza's

studies had discussed. Besides these fundamental works, Kabiye tone was also the target of a number of smaller studies in papers and conference presentations, mostly by Lébikaza and Roberts.

In examining this literature that determined the fundamental aspects of tone, it appears that their findings are as varied as the analyses themselves.

2.3.1 Distinctive Tones and Lexical Tonal Melodies

The inventories of distinctive tones and lexical tonal melodies of Kabiye have been controversial from the start of the research on this language. Although the phonological inventories of tone laid out in the studies differ on almost every aspect, most agree on the existence of two contrastive tones: /H/ and /L/. Establishing the inventory of lexical tonal melodies is even a more complicated issue for the studies, showing lesser agreement in their analyses. Table 2.12 summarizes their findings.

Table 2.12 Comparative Inventory of Underlying Tones²¹

Studies	Contrastive Tones	Lexical Tonal Melodies of Noun Roots	Lexical Tonal Melodies of Verb Roots	Lexical Tonal Melodies of Affixes		Lexical Tonal Melodies of Prefix Pronouns	Lexical Tonal Melodies of Conjunctions and Particles
				Noun Class Suffixes	Verb Suffixes		
Delord (1968, 1976)	/L/ /H/ /LH/ /HL/ /LL/ /HH/	/L/ /H/ /LH/ /HL/ /LL/ /HH/	/L/ /H/ /LH/ /HL/ /LL/ /HH/	/L/ /H/ /HL/	-		-
Paaluki (1995)	/L/ /H/ /M/	-	-	-	-	-	-
CLNK & SIL-Togo (1998)	/L/ /H/	-	-	-	-	-	-
Lébikaza (1985/1999)	/L/ /H/	/L/ /H/ /LH/ /HL/ /LL/ /LLL/ /LHL/	/L/ /H/ /LH/ /HL/ /LL/ /LLL/ /LLH/ /LHL/	/H/ /HL/	/L/ /H/ /LH/ /HL/	/L/ /H/	/L/ /H/
Kassan (1996)	/L/ /H/	-	/L/ /H/ /LH/ /HL/ /LL/ /LLL/ /LLH/ /LHL/	-	/L/ /H/ /T ₀ ²²	/L/ /H/	-
Roberts (2002, 2003)	/L/ /H/	/L/ /H/ /LH/ /HL/	/L/ /H/ /HL/	/L/ /H/ /HL/	/T ₀	/L/ /H/ /LH/	-

²¹ A dash in a column means the author did not investigate the corresponding topic.

²² A toneless suffix.

The following clarification is made about the tone inventories as reported in Table 2.12. Prefixes include noun class concord prefixes and subject pronouns. Suffixes include noun class suffixes as well as object pronouns. As concerns the inventories, one notes the following. Though Delord does not show tones on noun class suffixes, he states that there is a /HL/ melody on the plural suffixes of almost all the six types of noun classes (Delord 1968: 266). Furthermore, his examples include affixes with /H/, /L/, and /HL/ tones (see an example of /HL/ suffix in Delord 1976: 21). Roberts has specifically identified the underlying tones of only two verb suffixes: “/-kI/, 2nd marker of the Present Inaccomplished” and “/-kA/, 2nd marker of the Past Inaccomplished,” which are described as “underlyingly toneless” suffixes. But he also lists other verb suffixes without clearly specifying their tone (see Roberts 2002: 57-59, 66). The phonological synthesis of CLNK & SIL-Togo 1998 represents the high tone by an acute accent as in (é), the low tone by a grave accent as in (è); it also mentions a third tone, defined as a “lowered high tone”, which is indicated by a vertical line (') before a vowel carrying a high tone. According to the authors, the lowered high tone results from a sequence of a low tone and a high tone and is pronounced like a mid tone (CLNK & SIL-Togo 1998, page 6 of *Esquisse de Grammaire Kabiye*). These statements seem to indicate that the authors recognize only two underlying tones, low and high.

As Table 2.12 suggests, some of the studies on tone are more comprehensive and thorough than others. Only Lébikaza's research has investigated tone of virtually all the lexemes and affixes, therefore also providing the tonal melodies of conjunctions and

particles, information that the other authors have not researched. In considering the findings of the studies, it can be seen that the number of the contrastive varies from two to four and six. As noted above, all the studies share the view that /H/ and /L/ are contrastive in Kabiye. However, two of the studies go beyond these two tones to add extra contrastive tones. Paaluki's work shows the contrastive tones as /H/, /L/, and /M/, which the author specifically transcribed as “/’/: high tone, /˘/: low tone, /-/: mid tone (or lowered high tone)” (Paaluki 1995: 15). From five tonal realizations that Delord inventories initially in a sample sentence played on a flute (and transcribed with musical notes), he determines the first two tones, /L/ and /H/, which he qualifies as the basic contrastive tones (Delord 1968: 264 and 1976: 39). In examining more data, Delord determines four additional contrastive tones as /HH/, /LL/, /HL/, and /LH/ (Delord 1968: 265 and 1976: 45). Lébikaza's study (1985/1999) begins with a reanalysis of Delord's tonal sentence and identified only four tonal realizations, but the analysis of which also resulted in two tones as /L/ and /H/, which are the only contrastive tones of the language, according to Lébikaza. In fact, Lébikaza's studies are in agreement with those of Delord on the observation that surface *contour tones*²³ can only be realized on two morae. Nevertheless, these tones are understood differently in the research of both authors. Lébikaza explains them as sequences of the only contrastive /L/ and /H/, which happen to appear on consecutive morae. Instead, Delord

²³ Understand contour tones in the work of Delord, but non-identical tone sequences in the work of Lébikaza.

treats them as distinctive tones constituting underlyingly a unit (a contour tone) that can be viewed metaphorically on a one-mora-syllable as having one leg in the air and needing a second syllable on which to lay its second leg (Delord 1976: 45). The other studies agree with Lébikaza on /L/ and /H/ as the only distinctive tones.

In Table 2.12, one can also observe that the studies diverge on the number and the structure of the lexical tonal melodies. The studies of Lébikaza report the largest number of tonal melodies on lexemes. He identifies seven melodies on nouns roots, in contrast to six by Delord and four by Roberts. Roberts' four melodies are common to the studies of Delord and Lébikaza. Of Delord's two extra melodies, /LL and /HH/, Lébikaza's research acknowledges only /LL/, but further expands his inventory with two other melodies, as /LLL/ and /LHL/. On verb roots, Lébikaza's studies determined eight tonal melodies, which are confirmed in Kassan's work. Delord, on the other hand, lists six melodies on verb roots, and Roberts, only three. In addition to Roberts' three verb roots melodies /L/, /H/, and /HL/, common to all four studies, Delord also adds /LH/, /LL/, and /HH/, to his inventory, whereas Lébikaza and Kassan list /LH/, /LL/, /LLL/, /LLH/, and /LHL/. Lébikaza and Kassan did not confirm Delord's /HH/ melody, and they have added three other melodies.

The authors use different strategies to determine the lexical melodies. For verb roots, Lébikaza uses frames (*kí*-verb root-noun suffix and *qí*-verb root-noun suffix) within which he determines verb root melodies. The approach adopted in Roberts' research assumes the Imperative form of verbs to exhibit the underlying melodies. His

methodology, which is also informed by the Autosegmental theory's conventions, resulted in a reduction of Lébikaza's eight verbal melodies to three melodies. The strategy adopted by Delord is not well understood.

To show how the four authors would analyze the same verb roots differently, the strategies of Lébikaza (therefore, also Kassan's) and Roberts, have been applied to five sample verbs that are shown in Delord's research. Figure 2.3 schematizes the tonal analyses that the five verbs would receive from all four authors.

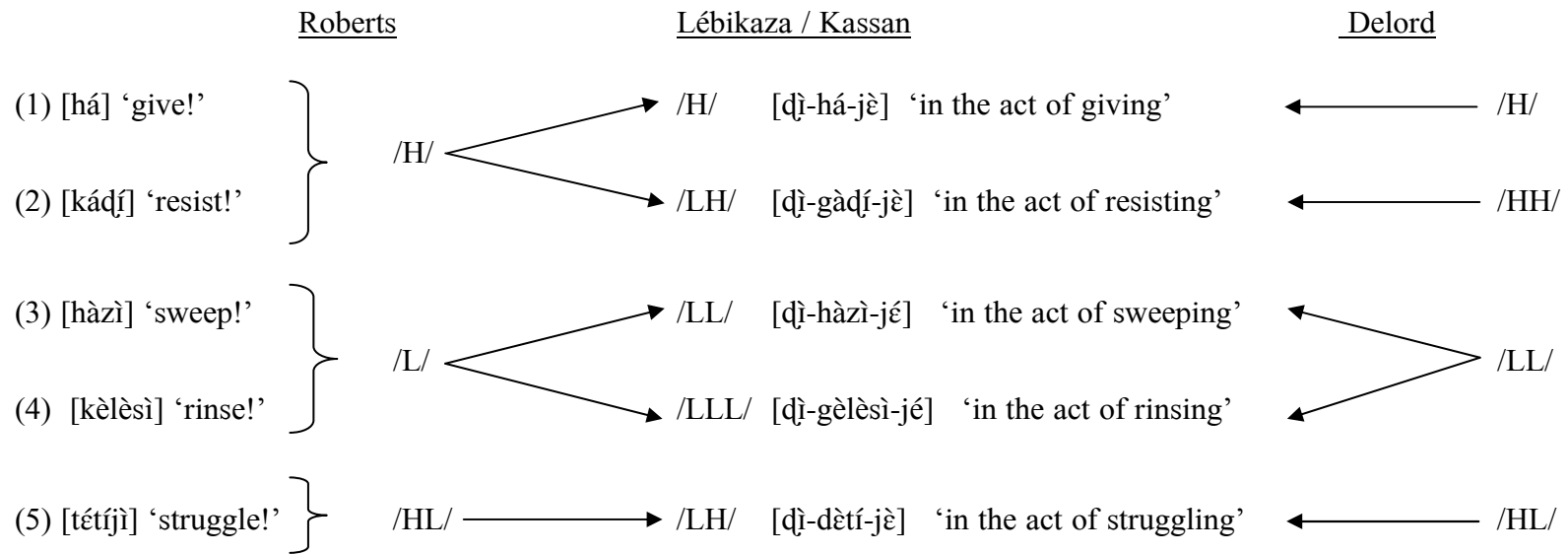

Figure 2.3 Comparative sketch of sample verb roots analyses by four different authors

As seen in Figure 2.3, the five verbs represent four tonal melody roots in Delord's analysis, in the right column. Based on the tonal melodies of their Imperative forms as shown in the left column, the five verb roots would be assigned three underlying melodies as /H/, /L/, and /HL/, in Roberts's analysis. The roots of the first two verbs, to which Roberts's analysis would assign a single /H/ underlyingly, would receive different melodies, as /H/ and /HL/, according to Lébikaza's and Kassan's analysis, shown in the middle column. Yet in Delord's analysis, one of these verb roots is assigned a /H/ melody and the other, a /HH/ melody. Thus, Delord's /H/ and /HH/ melodies correspond to /H/ and /HL/ respectively in Lébikaza's and Kassan's inventories that do not recognize any /HH/ melody for verb roots, whereas in Roberts's analysis, all these are assigned a single /H/ melody. Similarly, the third and fourth verbs that fall under a single /L/ melody in Roberts' analysis become two melodies according to Lébikaza's and Kassan's analysis as /LL/ and /LLL/, but one /LL/ melody according to Delord's analysis. While Lébikaza splits Delord's /LL/ melody into /LL/ and /LLL/, Roberts coalesces them into a single /L/ melody. The melody of the last verb root, on which Roberts and Delord agree as /HL/, is the complete opposite in Lébikaza's and Kassan's analysis, which is /LH/.

Differences in the analyses are also seen in the tonal melodies of noun roots, prefixes, and suffixes determined by some of the studies. But since it is difficult to pinpoint the strategies the authors have adopted in determining the tonal melodies for these items, it is not possible to make comparative sketches for these, as done for verb roots.

Other aspects of tone or topics related to tone are also treated in some of the studies reviewed so far and in more literature, focusing mostly on verbs. The tone categories of verbs in the various tense, aspect, and mood modalities are also subject of discussion in the grammars of Delord (1976) and Lébikaza (1999). Tone categories of verbs are debated within the larger topic of the verb system as it relates to discourse (Kassan 1996), or more specifically in the forms of the Inaccomplished aspect, and the Consecutive of the Aorist (Lébikaza 1994, Delord 1968, Badameli-Kassan 2000). Roberts' 2003 Post Master's thesis studies the tonology of modality prefixes that affect verbs. Other tone related studies include Roberts' 2003 treatment of tone spreading in the Associative Noun Phrase and Essizewa's 2003 study of the aspects of Kabiye tonal phonology from the Optimality Theory perspective, which also points out the implications for the correspondence theory of faithfulness. Tone and segment interaction is exclusively explored by Lébikaza with two conference papers in 2003, but only one published paper (Lébikaza 1989).

2.3.2 Major Tonal Phenomena Found in the Literature

The tonal processes described in the literature range from tonal phenomena such as downstep and downdrift to declination and simple repair strategies like simplification and erasure.

2.3.2.1 Downstep and Downdrift

Downstep and downdrift are often described as related tonal phenomena. The authors discuss them not only in slightly different terms, but also have a different

understanding of these phenomena.

According to Lébikaza (1999), downstep and downdrift occur automatically in Kabiye whenever there is a sequence of H_1LH_2 contour. In this context, the L rises one degree and H_2 lowers one degree so that both tones become realized phonetically on the same level as in [HMM]. L, on the one hand, thus manifests a “down-step” (or “*faïlle tonale*” in French, per his Rule-1 below) shown with 'H, while H_2 on the other hand undergoes “down-drift”²⁴ (or “*abaissement automatique*” in French, per his Rule-2 below) and triggers the lowering of tone in stair-like fashion. He formulated the following two rules to account for these phenomena.

(83) Rule 1 – Rule of downdrift and downstep (R1, Lébikaza 1999: 192)

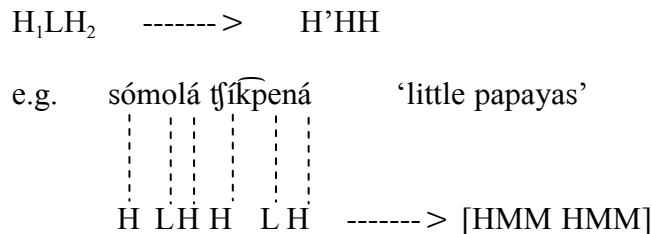

The exception is where both rules do not apply automatically and simultaneously in the sequence of $\widehat{HL}H$ in which \widehat{HL} is a contour tone.

In this case, only the second H is transformed by downstep according to the following rule-2.

²⁴ Though the author used the English words “down-drift” and “downstep” to refer to these phenomena described, it seems to us that he switched the name of one for the other, so that his “*abaissement automatique*” is actually the one usually referred to as downdrift, and the “*faïlle tonale*” is actually the one usually talked about as downstep.

(84) Rule 2 – Rule of downstep (R2, Lébikaza 1999: 194)

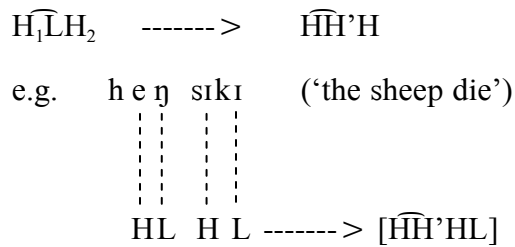

Delord (1976: 35-40) also observed the phenomenon of downdrift which he talks about in terms of tonal terracing and terrace rupture (“*terrasse tonale*” and “*rupture de terrasse*” in French). According to him, tonal terracing occurs when successive syllables in the tonal phrase come to carry H tones. Terrace rupture, in this context, refers to the point of lowering where each subsequent terrace begins. Indeed, in Delord’s view, the ideal phonological word has the contour [LHL], at least in isolation. In tending to satisfy that contour trajectory, an underlying melody such as /LHLHL/ will still become realized according to the [LHL] pattern, something like [LHHHL]. Therefore, in a sentence, a number of L tones might be realized as high due to the tonal environment. Hence, a series of successive syllables becomes realized high, forming stairs, the tonal heights of which drop progressively, and these stairs generally correspond to the phonological word. Delord illustrates this point with two sentences.

In the first, he uses superscripted numbers to represent tonal heights.

³dá-súwý ²tíkílá ¹téé
 ‘As for us, we live in simple houses’

The second sentence is illustrated by two diagrams, which correspond to the two tonal phrases of the sentence. The tonal heights are shown with curves.



‘I am going to sit in my farm ...’

(a)

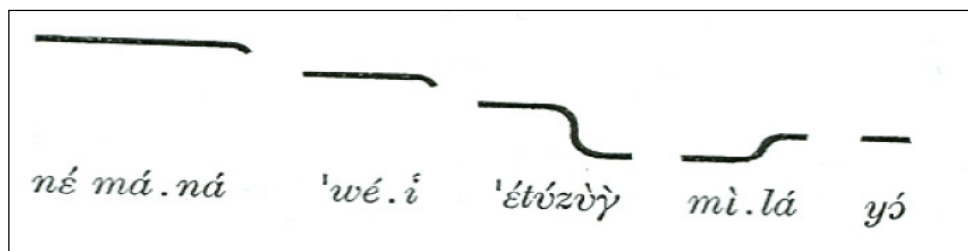

‘... and I will find out who pushes my sorghum plants down’

(b)

Figure 2.4 Delord’s (1976: 37) diagrams showing tonal terracing in the sentence: (a) tonal phrase 1, (b) tonal phrase 2.

From the perspective of Roberts (2002, 2003), downstep and downdrift, which are referred to as “automatic downstep” and “non-automatic downstep,” respectively, are a single phenomenon – the “lowering of tonal register” – taking place in two contexts: one *automatic* (when it is triggered by an associated tone) and the other *non-automatic* (when it is triggered by a floating tone). He argues that the lowering of tonal register occurs every time a H tone follows a L tone, with not only the H tone surfacing

on a register lower than that of a preceding H, but also with the pitch interval between the LH sequence always narrower than the interval between the HL sequence, even when this LH occurs utterance initially (where, there is no preceding H). He gives the following illustration.

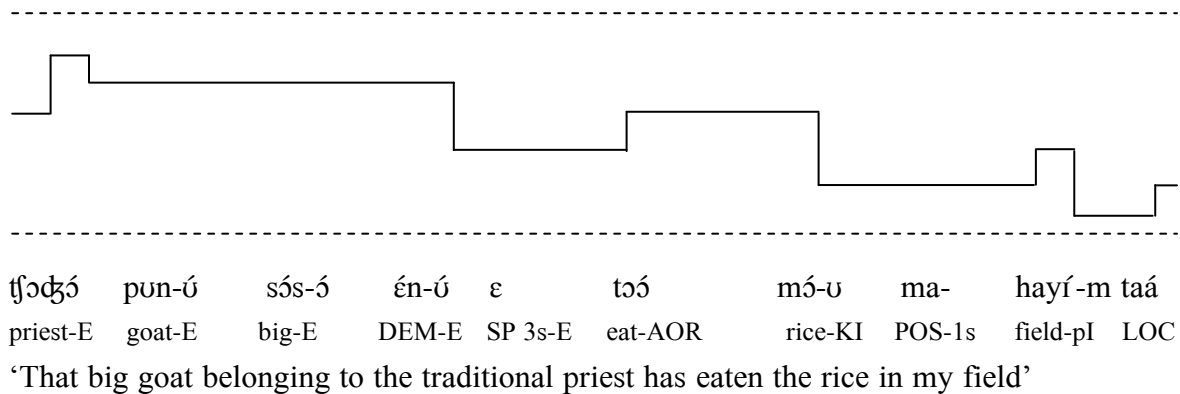

Figure 2.5 Roberts’ (2002: 44) diagram of Automatic Downstep

Roberts mentions two other tonal phenomena that neither Delord nor Lébikaza mentions: the first, which Roberts calls declination, is in some way similar to the phenomenon of downstep that has just been shown but involves only low tones and occurs at utterance final; the second is resistance.

2.3.2.2 Declination

According to the description of the tonal phenomenon of declination in Kabiye mentioned in Roberts’ works, a series of L tones in utterance-final position tends to descend in pitch.

The following diagram is given for example:

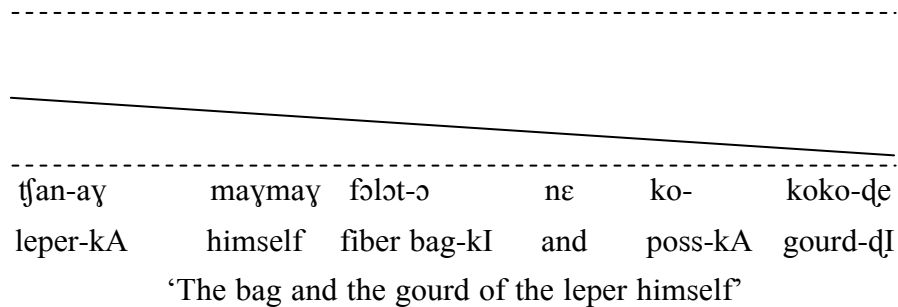

Figure 2.6 Roberts’ (2002: 44) diagram of declination

2.3.2.3 Resistance

Roberts’ studies also talk about tonal resistance. According to his studies, in utterance-medial position, two-mora sequences which do not contain a consonantal element (i.e., VV, Vy and VN) resist associating to the melody HL. The L tone delinks, and the H tone spreads right, onto the free segment (Table 2.13).

Table 2.13 Resistance of VV, Vy and VN sequences (Roberts 2002: 46)

Underlying form	<p> $\begin{array}{c} L \\ \\ ha \end{array}$ $\begin{array}{c} H \\ \\ a \end{array}$ $\begin{array}{c} L \\ \\ a \end{array}$ # $\begin{array}{c} L \\ / \quad \backslash \\ ma \quad y \end{array}$ $\begin{array}{c} L \\ / \quad \backslash \\ ma \quad y \end{array}$ </p> <p>women - -pA themselves</p>
H tone spreads right	<p> $\begin{array}{c} L \\ \\ ha \end{array}$ $\begin{array}{c} H \\ \\ la \end{array}$ $\begin{array}{c} L \\ \\ a \end{array}$ # $\begin{array}{c} L \\ / \quad \backslash \\ ma \quad y \end{array}$ $\begin{array}{c} L \\ / \quad \backslash \\ ma \quad y \end{array}$ </p>
Merging (OCP repair)	<p> $\begin{array}{c} L \\ \\ ha \end{array}$ $\begin{array}{c} H \\ / \quad \backslash \\ la \quad a \end{array}$ # $\begin{array}{c} L \\ / \quad \backslash \\ ma \quad y \end{array}$ $\begin{array}{c} L \\ / \quad \backslash \\ ma \quad y \end{array}$ </p>
Surface form	<p>[haláá maymay] <i>the women themselves</i></p>

2.3.2.4 Assimilation

In terms of assimilation phenomena, Delord’s analysis mentions tone spread on a final vowel that he refers to as “son coulé” (a “spread sound”). He also talks about a “plancher tonal” (i.e., a tonal plateau) sentence finally (Delord 1976: 38).

Two rules of “horizontal assimilation” have been formulated by Lébikaza: one is regressive and the other is assimilation from a distance. In the case of the regressive horizontal assimilation, the H of the accented suffix (CV+) of agent substantives that are derived from L-toned verb roots is imposed (H Spread) to all the syllables of the verb root when the substantive appears after a pause or after the H tone of a prefix. In possessive constructions where there is a floating L tone between possessor and possessed elements, this rule has no effect on substantives in the position of possessed constituent after the L-toned determiner.

(85) Rule 3 – Rule of regressive horizontal assimilation (R3 of Lébikaza 1999: 209)

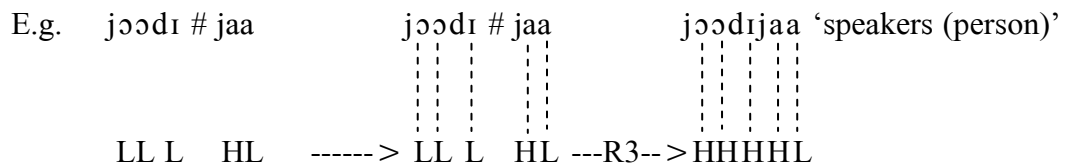
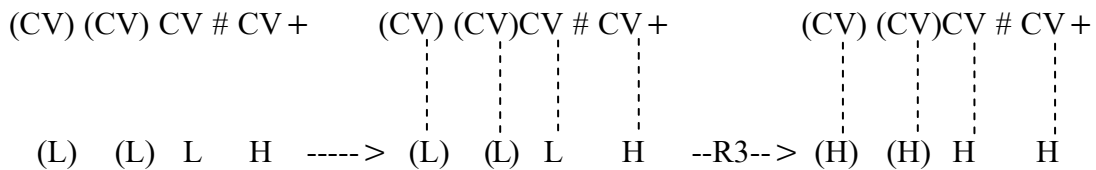

The second assimilation rule presented by Lébikaza, the assimilation from distance, applies only when the L tone prefix is used to derive nouns other than relational locatives (which are derived with the prefix *d̥i-* and the suffix *-jé*).

(86) Rule 4 – Rule of assimilation from distance (Rule-4 of Lébikaza 1999: 211)

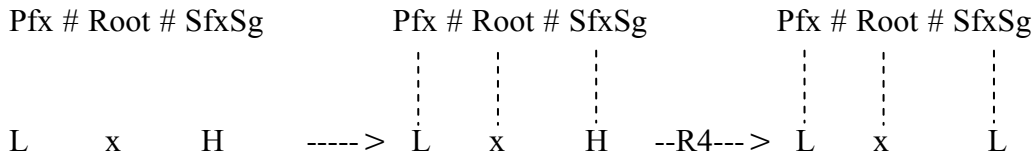

Note: x being the tonal melody of the root

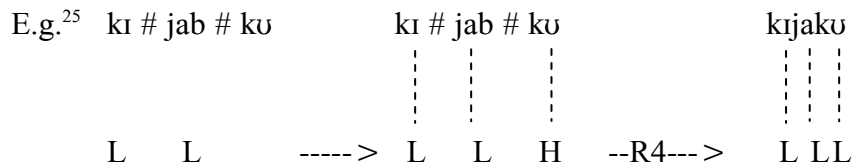

Assimilation is discussed by Roberts in terms of “vertical assimilation” (Roberts 2002) or “HLH plateauing” (Roberts 2003) and refers to the same phenomenon that Lébikaza called “downstep and downdrift” (see Lébikaza’s R1 in §2.3.2.1 on page 82). According to Roberts, a singly-linked L tone between two H tones delinks and the second H tone (with its downstepped register) spreads left onto the empty segment. Roberts uses association lines and spreading methods of Autosegmental theory to illustrate this process as in Table 2.14.

²⁵ We believe the H tone of the suffix is missing in the input tones listed for this example.

Table 2.14 Roberts Sample Derivation

Underlying form	
Vertical assimilation	
Non-automatic downstep	
Surface form	[ná 'tʃɔɔ] <i>See the priest!</i>

These assimilation phenomena in Kabiye are understood as L Spread and H spread in Roberts' work, whereas Lébikaza mentions only the H spread.

2.3.2.5 Dissimilation

Lébikaza (1985/1999) discusses two kinds of tonal dissimilation processes: one in lexical roots and the other in affixes. In affixes, two rules account for dissimilation. The first rule changes the suffix H to L after a root final H and the second rule changes the H tone or the H constituent of a contour tone of the suffix into a [L] after a verb root with a H tone.

(87) Rule 5 – Rule of dissimilation in the suffix -Part a (Rule-1a of Lébikaza 1999: 206)

The H of the singular class suffix is realized [L] when the last tone of the root is H.

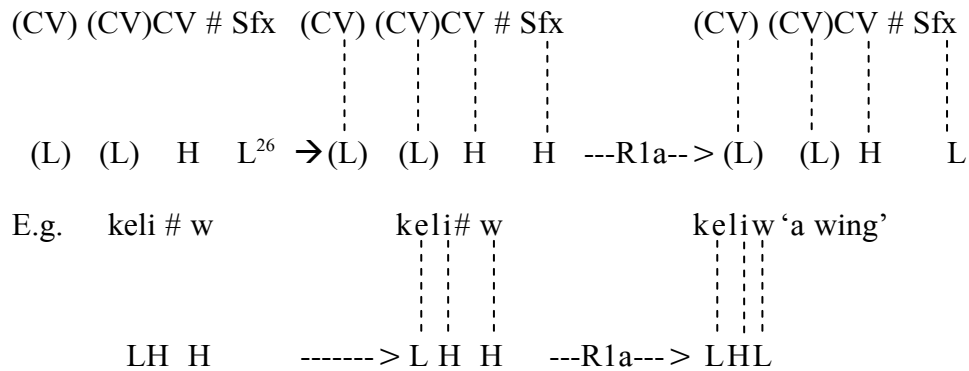

(88) Rule 6 – Rule of dissimilation in the suffix -Part b (Rule-1b of Lébikaza 1999: 207)

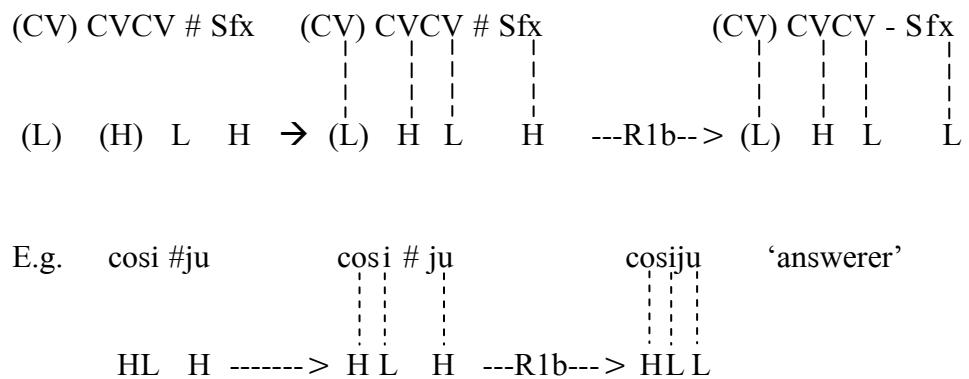

The only exception applies to the H tone of the suffix of the Accomplished (“accompli”) -a/H/ appearing after monosyllabic roots (see the Rule of dissimilation in the root below).

The dissimilation in the root is formulated as follows: The H tone of monosyllabic noun roots (short syllable of the Genre 3 substantive) is realized L before the plural suffix (see e.g. 1 below). This same rule applies to the H of the monosyllabic verb root before the H of the suffix of the Accomplished -a/H/ (e.g. 2).

²⁶ We believe that this “L” includes an error as the suffix tone is supposed to be an “H” that gets transformed into a L as worded by the author.

(89) Rule 7 – Rule of dissimilation in the root (R2 of Lébikaza 1999: 208)

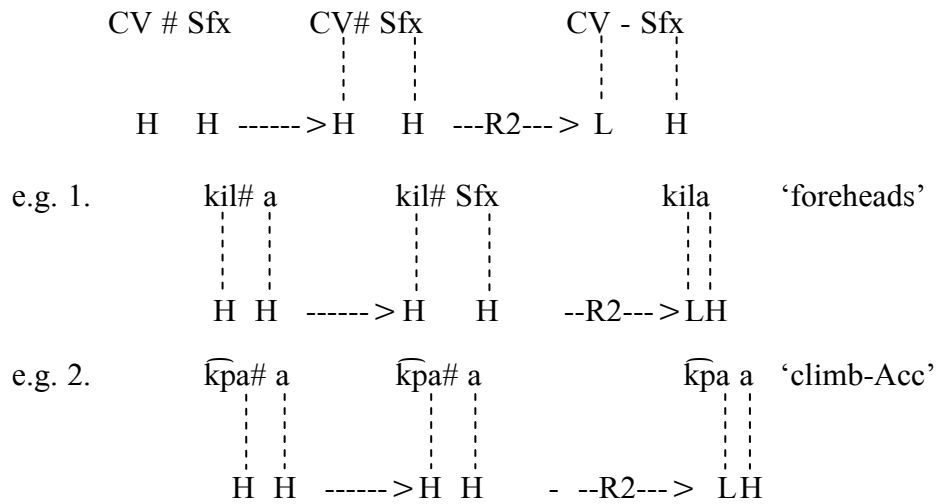

Roberts mentions dissimilation only in the case of the assignment of an L tone to two underlyingly toneless segmental suffixes (/ -kI/, 2nd marker for the Present Inaccomplished and / -kA/, 2nd marker for the Past Inaccomplished) in the derivation. The dissimilation takes place in the low tone verb roots, which are assigned a high tone (Roberts 2002: 57-59).

2.3.2.6 Erasure

Lébikaza and Roberts mention an erasure strategy in Kabiye, but Delord does not. According to Lébikaza, erasure occurs in polysyllabic roots ending in a vowel. The Low tone of the final syllable, together with its segmental support is deleted when the root is followed by a vowel initial long syllable suffix that has a contour tone.

(90) Rule 8 – Rule of erasure (Rule-6 of Lébikaza 1999: 214)

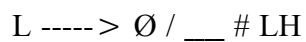

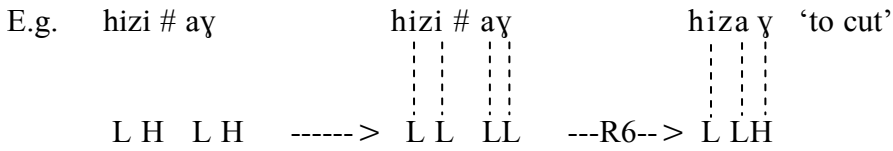

Roberts (2002: 58) talks of stray erasure as a lexical rule of repair strategy in his derivation of verbal forms. At the end of the lexical derivation, when a floating tone has done all the spreading and merging it can, it is erased.

In addition to the phenomena reported so far, Lébigaza has identified two more phenomena that neither of the other two researchers has, polarization and simplification.

2.3.2.7 Polarization

According to the rule of polarization formulated by Lébigaza, derivational suffixes do not have their own tone. Rather, they take the opposite value of the stem final tone. For example, the focus morpheme *-na* has no underlying tone, but receives the opposite value of the stem final tone.

(91) Rule 9 – Rule of Polarization (Rule-5 of Lébigaza 1999: 213)

Tone -----> [-α H] / [αH] ____

E.g.1

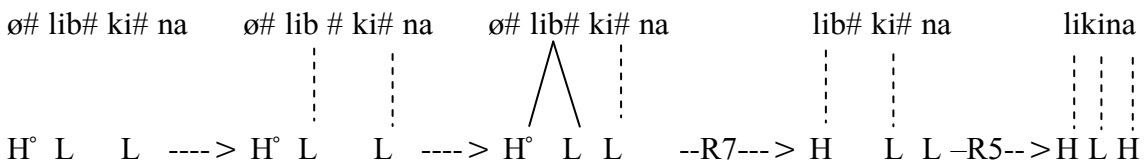

E.g.2

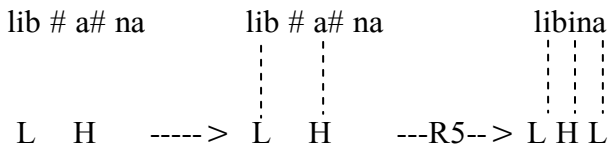

2.3.2.8 Simplification

For Lébikaza, when two tones (whether contour or not) are assigned to the same mora, a simplification process is triggered for pruning purposes. Hence, the sequences HH, LH and HL become realized as H when they are assigned to a single mora. In the same environment, LL is realized as L. The simplification process is accounted for by two rules in Lébikaza (1999, R7 and R8) that are reported here.

(92) Rule 10 – First rule of simplification (Rule-7 of Lébikaza 1999: 214)

$$\left\{ \begin{array}{l} /HH/ \\ /HL/ \\ /LH/ \end{array} \right\} \text{-----} > [H] / [\overline{\text{mora}}]$$

(93) Rule 11 – Second rule of simplification (Rule-8 of Lébikaza 1999: 215)

$$/LL/ \text{----} > [L] / [\overline{1\text{mora}}]$$

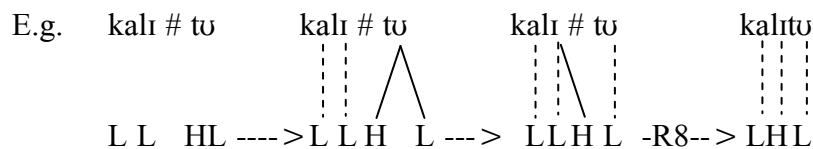

2.3.2.9 Other Tone Processes

Besides the tonal processes just described, a few other tonal strategies have been mentioned off hand by some of these authors. For example, we note merging as an OCP repair strategy mentioned by Roberts (2002: 58).

Delord (1976) also mentions other tone phenomena that appear to be random. He notices the following in two syllable phonological words (Delord 1976: 43):

a. When preceded by a low-toned element, /L/ is realized as [L] and /H/ is realized as [H].

b. When preceded by a high tone, /L/ and /H/ become both realized as [L] (/H.L/ → [H.L]; /H.H/ → [H.L]). But in the utterance, when followed by an H, these Ls are raised under certain conditions.

c. When followed by a low tone, /L/ will remain [L] and /H/ will remain [H] (/L.L/ → [L.L]; / H.L/ → [H.L]).

d. When followed by a high tone, /L/ and /H/ both become realized as [H] (/L.H/ → [H.H]), /H.H/ → [H.H]).

e. In isolated words of three syllable or more, /L/ will be realized [L] and /H/ will be realized [H], except in the following positions: When a /L/ is located between two /H/s, it becomes realized as [H] (/H.L.H/ → [H.H.H])²⁷, (/H.L.L.H/ → [H.H.H.H]); at word final and utterance final positions, /H/ become realized [L] when it is preceded by a /H/ (/LH.H/ → [LH.L]); a /H/ in the middle of a word that begins with a /L/ and ends with a /H/ can become [L] (/L.H.H/ → [L.L.H]).

A revised account of Kabiye tonology would ideally account for these sorts of apparent idiosyncrasies in a more systematic fashion.

²⁷ This phenomenon being described by Delord is very similar to the one Roberts discussed as “vertical assimilation” or “HLH “plateauing” (p. 90, Table 2.14) and Lébikaza as “downstep and downdrift” (R1 in §2.3.2.1 on p. 83). But it is noted that unlike the other two authors, Delord is not making any reference to the fact that in the [H.H.H] sequence the last two [H.H]s are realized at the same level, but not as high as the first [H].

2.3.3 Tonology of the Sentence

While both Delord and Lébikaza examined tones of words in isolation and in the phonological word, Delord does not get into the details of specific tone rules, but he does go beyond words to analyze the tonal pattern of the sentence as a whole. In this highest prosodic unit, Delord identified two “tonal phrases” that are separated by a significant pause and characterized by a falling high melody. One of the two tonal phrases is the domain of the downdrift process described earlier. In the other tonal phrase, when there is only one H-toned syllable, there is no terracing but only tonal peaks.

As it appears from this section, a substantial amount of research has already been done on Kabiye tone. However, the authors’ views are very distinct and have strengths and weaknesses that must be evaluated.

2.3.4 Assessment of the Previous Tone Analyses

Considering the phonological studies in general and tone analyses in particular, it can be claimed that some of the studies contribute more than others, specifically as concerns the scope of the research areas covered, the originality of the analysis, and the amount of detail given.

As the first linguistic account of Kabiye, the pioneering works of Delord (1974 and 1976) must be acknowledged for laying the ground for further research. Delord identified and described the segmental and suprasegmental units of Kabiye. Similarly, Lébikaza1985/1999 has touched almost all the linguistic domains of the language,

including tone. This work shows greater detail than Delord's and has the merit of using more recent linguistic theories of its time to account for the complex data and processes of Kabiye. After Delord (1976) and Lébikaza (1999), Roberts' works are also acknowledged among the most important research on Kabiye tone. Roberts 2002 was the first attempt to explain the basic tone configuration and tone functioning of Kabiye from an Autosegmental theory perspective, which he also examined further in his Post Master's thesis (Roberts 2003a) and a later paper (Roberts 2003b). In his descriptions, Roberts has also highlighted the striking interaction between word formation and tone processes in this language by drawing significantly on lexical phonology. However, despite the richness and the great discoveries in these studies, their analyses would benefit from some review and readjustment at various levels.

2.3.4.1 Limitations of the Previous Analyses of Tone

The most obvious of the limitations of the previous tone analyses are theory and scope-related. Most of the accounts, especially the two fundamental accounts by Delord and Lébikaza, use older linguistic theories, which are not as efficient in explaining tone as newer theories, such as Autosegmental theory. However, Roberts' accounts, which use newer theories, are not exempt from reconsideration and revision.

Except the studies by Roberts, all the existing fundamental tone accounts, represented by the studies by Delord, Lébikaza, and Kassan (to some extent), do not use modern theories. The remaining tone accounts (Paaluki 1995 and CLNK & SIL-Togo 1998), which are phonological summaries in lexicological works, are lesser explanatory.

Delord 1976 is pre-autosegmental and does not formulate complex rules, but he uses arrows to show tone processes and discusses tone phenomena such as downstep and downdrift using a different terminology. Lébikaza identified the largest number of tone phenomena and formulated rules to account for them. Though his account strives to use more modern linguistic theories to account for tones in the data, he does not use the proper notations of Autosegmental theory. Following Leben's (1976) theoretical approach, instead, he uses a combination of Autosegmental and suprasegmental theories, which are viewed as complementary models. Therefore, although his description of tone includes rule formulations, the rules only indicate the occurrence of changes in the data (as previously in Delord 1976) without explaining why and how they occur, as Autosegmental theory might. For instance, in Autosegmental phonology, assimilation processes are described in terms of spreading, which is shown by association lines, but in Lébikaza 1999, an assimilation process is simply indicated by an arrow. Kassan's (1996) tone analysis draws mainly on Lébikaza's (1985) analysis. Without reproducing *in extenso* Lébikaza's analysis, Kassan adapts it to apply to the related area of her research. However, in borrowing Lébikaza's (1985) analytical methodology, including theories and notations therein, Kassan 1996 has the same limitations of using an outdated theory. Since the studies by Delord and Lébikaza, however, linguistic theories and research tools have evolved significantly and now provide us with more powerful tools to better explain these processes. In that respect, Roberts' studies bring a unique contribution by using the Autosegmental theory to better

describe and explain the tones and the tonal phenomena. However, the accounts of Roberts have other limitations in common with the accounts of Delord, Lébikaza, and Kassan.

Although all tone studies have some limitation in scope, some are more limited than others. Despite the work they have accomplished, the descriptions of Delord and Lébikaza do not exhaust all the details of the linguistic description of Kabiye. For instance, the issue of tone constituted only a sub-topic in these monumental works, and therefore received only a small amount of attention and detail. In the identification of the suprasegmental phonological units, for example, Lébikaza did not show tonal derivations of surface forms from underlying ones in a systematic way, but only “as necessary” (Lébikaza 1999: 204). The tone accounts of Roberts and Kassan apply to even more limited portions of the language. Roberts’ tone analyses focused only on mono- and bi-syllabic verb roots and noun roots (Roberts 2002 and 2003). The rest of the lexical items are yet to be accounted for autosegmentally. His analysis, therefore, is limited in its scope and still needs to be extended to the remaining noun root and verb root classes of the language. Similarly, Kassan’s (1996) tone analysis covers only verbs and associated categories such as the verb phrase, tense, mode, aspect, and modalities. As Kabiye teaching materials, Paaluki 1995 and CLNK & SIL-Togo 1998 simply summarize their research results without delving into the analysis in any way. Yet, scope and theory limitations are not the only issues that undermine the main accounts on Kabiye tone. These accounts have other critical weaknesses.

2.3.4.2 Inconsistencies and Errors in the Literature

The tone descriptions found in some of the studies are replete with inconsistencies, many of which are striking. The inconsistencies are of three types: inconsistencies in the findings of the studies for the same topics researched, methodological inconsistencies within some of the studies themselves, and inconsistencies and errors in how tones are annotated in the data.

When the studies are compared, their results for the same topics vary greatly. For example, the number of contrastive tones varies from two in the studies of Lébikaza, Kassan, CLNK & SIL-Togo, and Roberts to three in the work of Paaluki and six in the studies of Delord. The studies are not unanimous on the tonal melodies inventoried either. One study might agree with another on the lexical melodies of one class of items, but all the studies are never unanimous on the melody of any single class of lexical items. For instance, in addition to the contrastive tones on which Lébikaza, Kassan and Roberts all agree as /H/ and /L/, Kassan also agrees with Lébikaza on eight tonal melodies for verb roots. However, Roberts does not agree with them and lists only three melodies for verb roots. In the same way, the studies of Roberts agree with those of Delord on the melodies of the noun class suffixes, but Lébikaza who also studies the subject has a different analysis. For the latter researcher, there are only two melodies - /H//HL/ - instead of three melodies listed by the former. For the melodies of noun roots, none of the three studies agree. Similar observations are true for the rest of the melodies of roots and affixes inventoried by the studies. For instance, it can also be noted that the

prefix kí- that is used in the prolific derivation of adjectives from verb roots in Kabiye is assigned a /H/ tone by Lébikaza (1999: 257) but was identified by Delord (1976: 247) with a /L/ tone. But, it is unsurprising that there is so much variation in the results of the studies, since these studies use varying methodologies, some of which are not well understood.

When it comes to the specific question of how the studies determine the underlying tones, such as contrastive tones and lexical tonal melodies, the criteria used by the researchers are not always clear. In fact, Paaluki 1995 does not provide any explanation of how the three distinctive tones were determined. The same could be said about the reference to tone in the phonological synthesis found in the dictionary of CLNK & SIL-Togo (1998). However, since these two documents are not phonological analyses *per se*, it is understandable that they do not lay out their methodology. But the fundamental phonological accounts of Delord, of Lébikaza and of Roberts have methodological issues as well.

It is unclear how Delord determines the underlying tones. However, at times, a same root receives different underlying melodies, as seen in the form of ‘guide’ which is attributed underlying /LH/ (pages 164, 171, 175, 177, 179) and /HH/ (pages 171, 175, 179) in Delord 1976. Furthermore, Delord fails to explain why he chooses certain tones as underlying, assuming underlying tones of certain lexical morphemes, which can change in different environments. For example, we note in §1.411, page 35, that the author gives the example $m\grave{a}\eta + k\acute{a} + b\grave{e}t\acute{i} + \grave{\eta} > [m\grave{a}\acute{a}b\acute{e}t\acute{i}-\grave{\eta}]$ ‘I will sell to you’ to

illustrate his point that the underlying tonal pattern /LHLHL/ of a phonological word will be realized as [LHHHL] following the [LHL] general pattern of the sentence, which he identifies earlier. However, Delord does not clarify how he came up with the tones /LHLHL/ as the underlying tones in /màŋ+ká+bétí+ỳ/ from the surface form [màábétí-ỳ]. Yet, as mentioned earlier, in Kabiye, tones of words change depending on the context, a fact that Delord did mention elsewhere in his book (viz. Delord 1976, page 39, §5, and on page 42). As a matter of fact, morphemes in the phrase exemplified by Delord can change their tonal melody in other environments such as in: [jée máŋkàbètíŋ] ‘if I sold you’, or [màŋkábétí] ‘then I will sell’. Thus, the tonal melodies in these examples no longer follow the [LHL] sentence pattern as identified by Delord, and therefore, his whole claim becomes questionable.

Lébikaza (1985/1999) sought to address the misinterpretations of Delord’s research, but failed to show enough clarity in his treatments. Though Lébikaza clearly laid out the methodology he adopted, it is not always clear how he got some of the underlying tonal melodies of lexical items. In the identification of lexical tones of verb roots, for instance, he uses substitution frames. His analysis deduced that within these frames (following the H-toned adjectival prefix kí- and following the L-toned locative prefix ḍi-), the tonal melodies on verb roots are “identical” to the underlying melodies. However, replicating his procedure on the same variety of Kabiye did not always result in the tones his data predict as illustrated on pages 195-197, in Lébikaza 1999. In his

examples²⁸ (1), (2), (6), and (8) specifically, the surface forms of the derived adjectives are tonally identical, supposedly, to the underlying roots *síb* ‘die’, *lem* ‘dry’, *sidí* ‘mix’ and *holósi* ‘sip’, and transcribed as *kísíbú* ‘dead one’, *kílémá* ‘dried ones’, *kísídíjè* ‘mixed one, and *kú-holósi-w* ‘to be sipped’, respectively. However, in comparing the former and the latter forms, the surface tonal melodies in the latter forms are not identical to the underlying melodies on the roots as stated by the author. Surprisingly, the transcription of the surface form for ‘dried ones’ given by the author, is *kílémá* (with all high tones), which is, in fact, an incorrect melody for that form. In addition, it needs to be pointed out that except of *kílémá*, all the forms, which are supposedly identical to the underlying melodies, include the very HLH sequence that is an environment suitable for the processes earlier described by Lébikaza as “downstep” and “downdrift” (cf. rules 1 and 2, in Lébikaza 1999, pp. 192-194). Yet, none of his surface melodies show these phenomena. Based on firsthand knowledge of the data, it is advocated here that the correct surface forms should show a downstepped high tone, (‘H), as *k’ísíbú*, *k’ílémá*, *k’ísídíjè*, and *k’úhólósiw*. Lébikaza failed to notice these tonal alterations, which, in fact, is another tone issue with the whole document.

In most cases, Lébikaza does not show tone phenomena such as downstep in his

²⁸ In his transcriptions, Lébikaza (1999), like other researchers on this language, has opted to show tone sparingly, marking only high tones (with an accute diacritic) on the TBU, in contrast with low tones, which are left unmarked (absence of diacritic). Therefore, any TBU with no tone shown as seen in the examples cited from these authors is assumed to carry a low tone. In our transcriptions of the data of this dissertation, however, we have decided to show both the high tone and the low tone on every TBU, for more clarity.

transcriptions of surface forms. For instance, the phonetic transcription of the surface realization of the same adjective /kí-sidí-je/ ‘mixed one’ is also shown as [kísidíje] (cf. example (19), page 138) instead of [kí’sídíjè]. At other times, his underlying representations of what looks like the same root appear with different tones in different parts of the document, without the author clarifying why. This is the case of /lón-e/ ‘location’ vs. /lon-á/ ‘locations’ ((34a) and (34b), page 168). It is also the case of the verb roots /kal-/ ‘to read’, /pa-/ ‘to dance’, /lib-/ ‘to swallow’, /k̄pe-/ ‘go home’, which appear sometimes with a H tone and other times with a low tone respectively as in /ε-kálɿ/ ‘he reads’ vs. /ε-kalaŷ/ ‘he was reading’, /pájú/ ‘dancer’ vs. /tɿpajé/ ‘place for dancing’, /e-líki/ ‘he swallows’ vs. /e-libá/ ‘he has swallowed’, /e-k̄pén/ ‘he goes home’ vs. /e-k̄pemá/ ‘he has gone home’, etc. (cf. his examples (4a) to (24b) pp. 164-165). In such cases, therefore, we cannot follow the accounts on underlying tones. Lébikaza seems to assume some underlying forms, without a thorough explanation of these primary data. Consequently, it can be said that Lébikaza was not always systematic in his derivations, and might have missed some generalizations on the underlying melodies. This point tends to be supported by the newer studies of Roberts that reduced the eight verbal melodies of Lébikaza to only three melodies.

Roberts’ studies exhibit two main shortcomings, one of which is related to the scope of his research as already discussed and the other is methodological. Like the work of Delord, there appears to be a breach in the methodology adopted by Roberts. Roberts never explained how he determined the /L/ and the /H/ as the distinctive tones

of Kabiye. Moreover, Roberts very strikingly “assume[s]” that the Imperative form of verbs illustrates their underlying tonal melodies, without considering how these forms may well also have various tonal patterns in other environments. The problem with this methodology is that it is not fitting to base any research on the mere assumption that the tonal melodies of the Imperative are the underlying melodies in Kabiye simply because “other researchers working on Gur languages have drawn the same conclusion” or because “in Eastern and Western Gurunsi languages, the Imperative is generally identical to the unmarked verb form, which, *hopefully*, bears the underlying tones of the verb root” (Roberts 2002: 40). Such a research approach is problematic because research should be based on *facts* and not *hope*, and it is especially problematic in the context of Kabiye since other researchers previously made different statements relating to the topic. Indeed, Delord (1976: 169) stated that the tonal melody of the Aorist coincides mostly with the tones of the verb roots, except for the low tone roots, which also receive a high tone in the Aorist to satisfy the requirement of a tonal summit for every verbal form. According to Kassan, on the other hand, the Imperative and the Consecutive are characterized by a high tone; she also adds that the Aorist, which is expressed by a zero marker, has the bare root form morphologically but not tonally (Kassan 1996: 58 & 102, Kassan 2000). By just assuming the tones of Imperative as the underlying melodies and not specifying any theoretical nor language internal evidence why those particular forms should be chosen as the underlying tonal forms in the case of Kabiye, Roberts failed to let his research and analysis be guided by the empirical

facts of the language, thereby disallowing any unique linguistic parameters that Kabiye might present. Under the belief that specific language facts (data) should primarily guide the research, one must argue that if the forms in the Imperative are indeed found to be the underlying tonal melodies, then one should be able to explain and show facts to support the claim.

Tone-related inconsistencies, which are mainly found in the works of Delord and Lébikaza, are sometimes errors in the tones of the data presented and, other times, inconsistencies in the tone analysis. These errors are seen not just in tones, but also in segments and even beyond. In Delord 1976, though there appears to be an effort on the part of the author to show tone in the examples throughout the book, tone is not always consistently shown on TBUs, a fact that does not allow a correct reading of each word. Other data include tone errors, which in turn either obscures the author's analysis or becomes a hindrance to the understanding of his analysis altogether (to cite a few examples: see *'étúzuy* 'who pushes over'²⁹ (page 13) instead of *'étúzúú* 'who pushes over'; *màmbòqé* 'my bud' (page 29) instead of *màmbóqè* 'my bud'; *làḡhòlòmíyè* 'joy' (page 33) instead of *làḡhòlòmìyè* 'joy'; *qòó* 'mother' (page 41) instead of *qòò* 'mother'

²⁹ It is obvious from this example that there is actually a confusion of two different words on the part of Delord: he incorrectly attributes the gloss 'who pushes over' to the word *'étúzuy*, but the right transcription, which would have corresponded to Delord's gloss as 'he pushes over' is *'étúzúú*. The form *'étúzuy* that he used has a combination of vowels and tones that has no meaning in Kabiye. However, the tones of the transcribed form used by Delord are rather consistent with the tones of the analogous form that has the non-constricted (or [+ATR]) set of vowels instead, *'étúzùù* 'who moves'. The use of [-ATR] vowels, instead, combined with the tonal melody in Delord's transcription renders his form meaningless. It is also noted that this confusion on Delord's part was already pointed out by Lébikaza (1999: 185).

vs. *dòó* ‘night’; *nìw* ‘to understand’ (page 163) instead of *níw*, *tè̀m* ‘to finish’ (page 164) instead of *tém*, and so forth). Likewise, on page 42, the example *ù nà dâ-càà* ‘then, respect our father’ has a tonal realization shown by Delord as [B.B.B...], but the morphemes in this examples never have such a surface tonal pattern in Kabiye; the correct tonal pattern should be: [*tì nà dâ-càà*] ‘then, respect our father’. But, even worse, there are counterexamples such as [*é nà dâ-càà*] ‘he then respected our father’ that contradict Delord’s point. As one can see, indeed, [*nà*] ‘respected’ carries a high tone in this environment. In the same paragraph, the author states that no matter what the environment, the tone of the word *cá* ‘searched (for)’ remains high, as in *èk̀̀m cá newú* ‘the stranger searched for the younger brother’. Yet, in an example such as [*èk̀̀m nà, cà.à newú*] ‘stranger, search for the younger brother !’, the root of the Imperative [*càà*] ‘search!’ must carry a low tone as shown. It thus appears that Delord’s work, developed from the perspective of a linguistic outsider³⁰, includes incorrectly transcribed tonal forms, meaning that the ensuing analysis of tone is erroneous, at times. Similar errors, though fewer, are also seen in his segmental transcriptions. As a matter of fact, throughout Delord’s book, the Kabiye language itself is referred to as “kabrè,” which appears to be an old French distortion of [*kà̀̀jè*] ‘Kabiye’ that failed clearly to take into

³⁰ The author in fact states: “Nous, Européens, avons l’habitude de considérer la hauteur mélodique comme un des caractères de l’accent d’intensité; nos sommes alors tentés de noter comme syllabe haute la syllabe accentuée” (Delord 1976: 38).

“We, Europeans, have the habit of considering the melody height as one of the features of the intensity accent; we are thus tempted to choose the high syllable as the accented syllable.”

consideration the important scientific fact that this language does not allow a consonant cluster such as [br]. The title on the front cover of the book though, appears as “Le Kabiye,” which in fact is an improvement from “Le Kabre” that appeared on an earlier version in 1975. Some of the other data listed in Delord 1976 such as *tííya*, *tíísi* ‘bush, bushes’ (page 28) are recognized as specific to the Likpá and Lá'máqǵisi varieties of Kabiye (following Delord’s classification), which were not the focus of the author. The forms of other words listed by Delord were unrecognizable and it is unlikely that the Kèwe variety of Kabiye that Delord worked has radically changed since his book was written. However, that remains something to be verified.

Lévikaza 1999 failed to correct many of the tonal inconsistencies in Delord’s research because of its own inconsistencies stemming from typographic and formatting errors that pervade the book. These typos and formatting errors sometimes obscure the understanding of the explanations in Lévikaza 1999, especially in regards to tone when the illustrations include tone errors. To cite only a few of such errors: on page 196 of the book where the author illustrates the underlying melodies of verbs, the /HL/ melody is shown twice – in examples (5) and (6) – but the /LH/ melody that is mentioned in the text is missing from the list. Through the reading, it became apparent to us that the /HL/ in example (6) should have been written as /LH/. Similarly, in the segmental formulation of his Rule-1a on tonal dissimilation in the suffix (R-1a, page 206), the tone of the suffix is shown as L whereas the text and the examples talk about H tone (see this rule reproduced in §2.3.2.5 as Rule of Dissimilation in the Suffix –Part a and

footnote 26). Moreover, in the data illustrated in Lébikaza's book, some words are written both with and without a H tone, leading to the confusion that they carry a low tone³¹ in the second case and resulting in the wrong data. On p. 44, for instance, the same Kabiye word for 'to lay down' is shown a first time in the phonetic transcription with two H tones and a second time in the practical orthography with only one H tone as [súú] and *sú*. One also finds on the same page [héú] and *héú* 'to cut off'. It is apparent that these transcriptions should both carry two high tones just like the other examples from the same list that have similar tones. Other examples are [süyé] and *súyé* 'drum', [syyú] and *súyú* 'spinal pain' (page 42); /yóyáa/ and [yøyáa] 'warriors', which should have been [yóyáa] (page 173), [téálím] and *téyílím* 'clear fermented drink', and [káalím] and *káyílím* 'non ripe peanut' (page 43), etc. Typos affect not only tones but also segments. To cite only one example of this kind, on pages 165 and 168, some of the phonological transcriptions oddly show both the voiceless stop /p/ and the voiced /b/, but Lébikaza's inventory of phonemes includes only /p/ (cf. his consonants reproduced in the present research as Table 2.8 on page 63). Overall, the typos make his analysis confusing. Errors in Lébikaza 1999 are not limited to data: there are formatting errors too. For instance, in the phonology section, from page 45 through page 85, while

³¹ We note that Lébikaza opted in his book to show only high tones (with accute diacritics) on the TBUs in contrast with their absence when the tones are low. Therefore, even though the first form of each word he listed is the phonetic transcription and the second form is meant to be the practical orthographic transcription, it should be pointed out that the official orthography of Kabiye does not show tone at all and tone marking in both transcriptions was supposed to follow the same pattern as opted by this author.

his treatment of the vowel system continues, the title indicated in the header of the book reads “Consonant System”³², which was to be treated next. Likewise, from page 357 to page 361, the title shown at the top of the page in the header is “Substantives,” while the treatment of the “verbs” continues. For a substantial portion of the book (page 363 to the end), the page numbers indicated for titles in the table of contents do not correspond to the actual pages in the document. Other typos and formatting errors include the use of [] instead of // (page 139 (27a)), one “/” of a transcription missing (as in (20a), page 138), the second part of square brackets (]) missing (cf. (16a), page 198), the section number 2.1.5.4. missing between section 2.1.5.3. and section 2.1.5.5. (pp. 199-202, as well as from the table of contents), the use of the French *sourde* ‘voiceless’ instead of *sonore* ‘voiced’ (page 140), and so forth. Although most of the errors in Lébikaza’s book are obviously recognized as unfortunate typos, it is not always clear whether some of the underlying forms that Lébikaza identified also include simple typographical errors or represent something of greater substance.

As it can be seen, inconsistencies and errors from diverse sources, which affect tones and also segments, pervade the most fundamental studies of Kabiye, often obscuring the understanding of the analyses themselves.

³² This is our translation of the French “Le système consonantique”.

2.3.4.3 Lack of Phonetic Investigation of Tone

Another major deficiency that needs to be pointed out regarding the literature as a whole is the scarcity of phonetic analyses in general, but phonetic investigations of tone in particular. Two instrumental investigations of this language exist, both of which are very recent. The first is by Merchant Goss and Doran (2003) on the voicing stops in Kabiye. The second is by Edmondson and Esling (2006), which demonstrated the laryngeal basis of the feature ATR in laryngoscopic case studies on a number of languages including Kabiye. Phonetic investigations of tone on the other hand are based on auditory impressions only and are rudimentary.

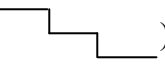
The only phonetic consideration of tone in the Kabiye literature appears on a few pages in Delord 1976 and Lévikaza 1999, which constitute the fundamental and foundational analyses. The phonological accounts of tone in both studies start with a short analysis of the tone of a sentence played on a flute and both authors use musical notes of a piano and stair-like lines (like these: ) to show the various heights of tonal realizations. However, it can be said that studies based on such instruments tend to lead to quite impressionistic analyses. Indeed, both studies, which analyzed exactly the same sentence, found different phonetic tones: Delord 1976 found five tonal heights, but Lévikaza 1999 found only four tonal heights. Today, there exist better tools that can be used to improve these accounts of tone.

This assessment has shown that many of the studies existing on Kabiye have laid the ground work on the description of this language and have undoubtedly achieved a better understanding of its tone, but these studies include various issues that will need to

be addressed in a revised account of Kabiye phonology. Among these issues are the outdated character of the theories used in most of these studies, methodological issues, analytical inconsistencies, and even typographical errors. All of these issues conspire together to undermine the analyses at many levels. They create confusion in many places and constitute a hindrance to the understanding of parts of the analyses. In addition, analytical inconsistencies in the methodologies and inconsistencies in the results across studies also make these results questionable. They have therefore not always been successful in their endeavor to determine and explain the very basics of the language – the tones and segments – upon which further research should stand. Hence, these foundational studies are weak. These descriptions mostly remain pioneering works that need revision and readjustment at various levels of the analysis to achieve a more accurate description of Kabiye and to confront the body of linguistic theory, especially on African languages, with empirical data from a language with the special features of Kabiye. Such is the main task of the present research. The revision of tone analysis is proposed in Chapter 6, following an exposition of the methodology used and the statement of the research questions in the next chapter, and the revision of the segmental phonology in Chapter 4 and Chapter 5.

CHAPTER 3

FRAMING THE RESEARCH: MOTIVATION AND METHODOLOGY

3.1 Motivation of the Present Research

The current research is directly motivated by the weaknesses and gaps found in the existing phonological studies, previously discussed in the literature review. It follows from the assessment of this specific literature that despite the amount of research already completed on Kabiye phonological analysis, there are misanalyses that must be addressed and important gaps that need to be filled. More generally, there is a lack of a solid, fundamental, and foundational work in both the phonetic and phonological descriptions, which is needed to provide a unified account of segments and tone. The revised analysis of Kabiye segments and tone proposed in the current research is intended to serve as a step toward addressing these weaknesses and filling these gaps. Therefore, the current research seeks to answer some specific questions, which are laid out in this chapter. The conceptual and methodological approaches adopted for the collection and analysis of the language data are also explained.

3.1.1 Goals of the Research

The primary goal of the current research is to fill the gaps in the existing phonological accounts of Kabiye segments and tone, thereby providing a unified

description of segments and tone that offers better generalizations in order to rectify the errors and misanalyses found in existing descriptions. To this end, the current study endeavors to provide a foundational description, which better accounts for and firmly establishes the basics of Kabiye phonology. This study will specifically investigate distinctive tones and lexical tone configurations in roots and affixes. It will further discuss some phonological phenomena underlying tone changes in lexical constructions and offer acoustic descriptions to illustrate the physical nature of tone. Therefore, the task of the current study comes down to a revision of Kabiye phonological description, which will bring further insights into the analysis based on supporting facts. In this process, a phonetic component is necessary, not only for its contribution to phonology, but also for the completeness of the research for documentational purposes. Acoustic investigations can shed more light on the understanding of the phonological categories of tone.

3.1.2 Statement of the Research Questions

The current research seeks to answer the following fundamental question: What truly are the surface and underlying segments and tones of Kabiye? This question is complex in itself and needs to be further examined in three component questions, each of which has further sub-component questions.

1. What are the surface and underlying consonants of Kabiye?
 - a. What are the phonetic consonants?
 - b. Which are the contrastive consonants and do they include a phoneme /ɣ/?

- c. What determines voiced and voiceless consonants alternations?
- 2. What are the surface and underlying vowels of Kabiye?
 - a. What are the phonetic vowels?
 - b. Which are the contrastive vowels?
 - c. What is the phonological nature of the “pharyngealized” or “velarized” vowels described by the literature?
- 3. What are some basics of the phonetic and phonological nature of Kabiye tone?
 - a. What are some basic acoustic properties of tone?
 - b. What are the distinctive tones and the lexical tonal melodies of word roots and affixes?
 - c. What are the major tonal alterations in the phonological word?

Such are the research questions set forth in this study, the answers to which will yield the needed general revisions of Kabiye segments and tone. In order to achieve the ultimate goal, a specific approach, as laid out in the following sections, is adopted in this research.

3.2 Methodology

The methodology adopted is three-fold, including the theoretical framework, the methodological approach, and the definition of the scope of the research.

3.2.1 Conceptual Approach and Theoretical Framework

The research design of this study involved three phases, the first of which consisted in a field trip to Togo to collect empirical data. The second phase was devoted

to phonetic transcriptions of the data, extraction of pitch tracks, and pitch F_0 measurements. In the third phase, segments and tones occurring in the data were analyzed phonologically and acoustically.

Data of the Kèwè variety of Kabiye were collected through elicitation techniques and digital recordings for examination. The choice to focus on the Kèwè variety of Kabiye dialects was motivated by the fact that it is the variety spoken in the headquarters of the Kabiye land, taught in schools provisionally as the standard variety, and analyzed by all the literature reviewed. Furthermore, Kèwè has the largest number of speakers and is usually the variety with which outsiders are the most familiar and commonly refer to as “Kabiye” itself. Various speech styles were chosen in order to elicit a wide variety of naturally occurring data and ensure the capture of specific constructions to help test tones of the words and tonal alterations in combinations of words. Therefore, words occurring in isolation, in phrases, and in full sentences were elicited using wordlists, impromptu stories, and specifically designed word games, which use substitution frames following the procedure proposed by Pike (1948), whereby words with certain tonal patterns, either all high or all low, are substituted in frames. Examples of the substitution frames used include:

- tò zì _____ dɔ̀dɔ̀* ‘say _____ again’
á ní _____ é ná? ‘who has ever heard _____?’
pà-_____ ‘their-_____’
jà-_____ ‘your-_____’

kí _____ ‘prefix for adjective formation’ and

qì _____ ‘prefix for locational relative substantives formation’.

Popular traditional oral stories were also recorded. All the data were digitally recorded on a computer equipped with an audio interface device for the best possible on-site recording quality, using the software Cool Edit set at 22050 sample rate, mono channel, and 16 bit resolution. The recordings took place in a room to minimize external noise. A narrow phonetic transcription of the data was adopted for the double purpose of capturing manifestations of the sounds and allowing a better observation of the changes affecting the sounds in different environments. As appearing in the illustrations presented in this document, tone is shown over the Tone Bearing Unit (TBU) in the transcriptions as follows: high tone is shown by an acute accent (´), low tone by a grave accent (`), and downstepped high tone by a superscripted exclamation point before the affected syllable.

The data analysis sought to examine vowels, consonants, and tones in morphemes and in words occurring in isolation and in included positions. Autosegmental phonology was used in tone analysis to understand and explain tonal configurations in morphemes, and tonal alterations in lexical items and phonological words, seeking linguistic evidence that reflects the tone patterns. For the acoustic analysis, representative examples of the tonal contrasts were digitally recorded and analyzed acoustically. The data were chosen to minimize artifacts from the phonetic environment. For instance, in order to minimize, as much as possible, the effect of the

preceding consonant on the pitch of the vowel, only vowels preceded by certain consonants were chosen: voiceless consonants (especially stops) were considered as the consonants with the least influence on pitch, and voiced stops were the next preferred consonants preceding the vowel. Words in which a sonorant preceded the vowel were avoided, as sonorants are known to have a greater effect on the following vowel. In order to also avoid the influence of tone from a preceding or a following segment, the vowels in monosyllabic words appearing in isolation (as in a wordlist) were preferably chosen. The wave files of the recorded words were then imported into PRAAT set at a frequency range of 70 Hz to 150 Hz. The F_0 values were extracted and their pitch trajectories plotted.

3.2.2 The Subjects

The participants in this research were chosen following predefined characteristics based on their language mastery level and their availability to serve as volunteers. The subjects were identified as native Kabiye speakers, age 35 and older, who lived in the Kabiye native area for at least the first 25 years of their lives. They were also native speakers of the Kèwè variety of Delord's (1976: 443) classification, which includes for this research the Kabiye varieties spoken in the localities of Lama, Tchitchao, Pya, Lassa, and Somdina. The specifications for subject selection were motivated by the fact that many Kabiye natives are born outside of the native area. Therefore, their language is often influenced by other languages, and they are unable to sustain a fluent conversation in their native language without code-switching, often to

French or Ewe. Hence, the Kabiye they speak is quasi-pidginized. This effect is also observed in the speech of young Kabiye people who leave the native Kabiye area early –for various reasons, such as work or higher education. Therefore, it was a necessary to set specific parameters about the choice of the subjects in order to ensure that the elicited data are representative of the true Kabiye language.

A total of seven male speakers participated in the study. Females could not be considered because of unavailability during the data collection timeframe.

3.2.3 Data Collection Procedure

The data collection took place as follows. First, the subjects were read words from a French wordlist including nouns and words referring to common things and concepts such as *soleil* ‘sun’, *eau* ‘water’, *chien* ‘dog’, *arbres* ‘trees’, *œil* ‘eye’, *chemise* ‘shirt’, *lire* ‘to read’, *rire* ‘to laugh’, *manger* ‘to eat’, *petit* ‘small’, *rouge* ‘red’, *beaucoup* ‘much’, etc. (see Appendixes). They were asked to give translations or equivalents of those words in their native language after each word was read to them. Given that most Kabiye speakers were bilingual (Kabiye and French), this approach was successful. The subjects who were not conversationally fluent in French, however, were only given prompts in Kabiye and an explanation about the kind of data that was needed from them. Then they were allowed to create their own list at random. A few expected synonyms occurred in the collected Kabiye data that the subjects provided, but these did not represent a problem for the analysis since any word was suitable for consideration in the study. The subjects were then engaged in word games where they were asked to

fill the blanks within substitution frames with the correct forms of specifically chosen words that were given to them in a list. Examples of elicited phrases include *sa voiture* ‘his car’, *leurs chaussures* ‘their shoes’, *ce chien* ‘this dog’, *mon chien* ‘my dog’, *la voiture du père* ‘father’s car’, *le chien perdu* ‘the lost dog’, *eau buvable* ‘drinking water’, and so forth. Finally, each subject was asked to tell two stories. The recording sessions lasted about two hours at a time with a ten minute break between the hours.

3.2.4 The Analysis

After the phonetic sounds were inventoried, the environments in which the vowels, consonants, and tones occur were then studied to determine allophonic variants of the same underlying sounds. In order to identify the underlying tonal melodies of morphemes, changes in the tonal melodies of word roots and affixes were examined in “isolation” and in “included” positions. The melodies of noun roots and noun affixes were first examined in wordlists, then in possessive constructions following the L-toned possessive pronoun /bÁ-/ ‘their’ and the H-toned possessive pronoun /nÁ-/ ‘your’³³. Nouns with all the class suffixes were chosen. A similar strategy was used to examine the tonal melodies of verb roots. Verbal paradigms of various forms such as the Infinitive, the Imperative, Accomplished, Past Inaccomplished, verb root following the H-toned adjectival prefix kÍ- and the L-toned prefix of the location deverbal

³³ In context, the vowels of subject pronouns take specific qualities that alternate depending on the vowels of the roots to which they are attached in accordance with Vowel Harmony and [CONSTR] / [RTR] Harmony.

substantives *dī-*, etc., were examined. The exact environments of the occurrence of tonal phenomena were also determined to provide an account of rules that govern them.

3.2.5 Scope and Limitations

The scope and limitation of the current study are defined as follows. The analysis proposed in this research is mainly concerned with the physical and psychological properties of tones and segments; the analysis does not include other prosodic elements such as accent and intonation. Tone analysis is conducted only in the phonological word³⁴.

The examination of the tonal melodies of roots and affixes that considers only noun roots and verb roots, which constitute the vast majority of roots in the language. Only the tonal melodies of noun suffixes will be determined.

This study does not extend to the tonal melodies of verb suffixes³⁵, which are so varied and could make another dissertation on their own, since verbs can be inflected in many forms that reflect tense, aspect, and mood. Therefore, verb roots are examined within nominal frames i.e., after a nominal prefix and before a nominal suffix. The frames used are the same as those used in Lébikaza 1999 to determine verb root melodies.

³⁴ The phonological word in Kabiye consists of the root and its optional expansions such as prefixes and suffixes. Though subject pronouns are treated as pronouns and part of the phonological word, object pronouns are not and they keep their own pharyngeal features, which are always [-RTR] or [-CONSTR].

³⁵ The reader is referred to Roberts 2003 for the phonology of modality affixes of Kabiye (see bibliography).

CHAPTER 4

REVISION OF KABIYE CONSONANTAL PHONOLOGY

4.1 Introduction

This chapter revisits the phonological analysis of Kabiye consonants in order to help either settle on the most adequate analysis among the previous studies or provide an overall revision to the analysis. Although the data reanalysis conducted in the current study confirms many of the results in previous analyses, at many other points, the current study also points to results different from those found in the literature, therefore leading us to revise the phonetic and phonological analyses of consonants.

Since the task of the current study is one of a revision, the presentation of the results often draws on previous analyses in order to ensure that the current study appropriately confirms the findings in these analyses (rather than present them as new findings). Therefore, aside from the points with which the current results are in complete disagreement with earlier studies, references are often made to the existing literature on Kabiye, mostly to Lébikaza's work, which stands out as providing the most detail and argumentation, but also to other studies as necessary. Indeed, while all the previous studies have contributed to the new analysis in various inspiring ways, many points in Lébikaza's analysis serve as a bridge to the new insights in the current analysis, in which many issues are given more in-depth analysis.

4.2 Revised Phonetic Inventory and Classification of Consonants

In addition to determining the complete inventory of Kabiye consonantal phones, one of the tasks of this dissertation includes verifying Lébikaza's phonetic inventory in the data newly collected for the current research. The new phonetic inventory, classified by manner and place of articulation of the consonants, is given in Table 4.1, along with illustrations.

Table 4.1 Phonetic Table of Consonants Classification

Manner of Articulation	Place of Articulation	Consonant	Orthography	glosses	
<i>Plosives or Stops</i>	<i>Bilabial</i>	[p]	[pèlé]	<i>pεε</i>	'girl'
		[b]	[àbàlú]	<i>abalú</i>	'man'
	<i>Alveolar</i>	[t]	[tóm]	<i>tɔm</i>	'language'
		[d]	[kùdòj]	<i>kudɔŋ</i>	'sickness'
	<i>Retroflex</i>	[ʈ]	[ʈóm]	<i>ɕɔm</i>	'salt'
		[ɖ]	[sɛ̀ŋɖɛ́]	<i>seŋɖe</i>	'rat'
	<i>Labial-Velar</i>	[kp̠]	[kp̠ínè]	<i>kp̠ine</i>	'animal'
		[gb̠]	[ɛ̀gb̠ám]	<i>εgbam</i>	'hunter'
	<i>Velar</i>	[k]	[kójè]	<i>kɔye</i>	'medicine'
		[g]	[ɛ̀gò̀m]	<i>εgɔm</i>	'guest'
<i>Affricates</i>	<i>Palatal</i>	[tʃ]	[tʃàlím]	<i>calum</i>	'blood'
		[ɕ]	[ɛ̀ɕám]	<i>εjam</i>	'weak person'
<i>Fricatives</i>	<i>Labio-Dental</i>	[f]	[fɛ́]	<i>fɛye</i>	'shame'
		[v]	[ɛ̀vèbú]	<i>evebu</i>	'young man'
	<i>Alveolar</i>	[s]	[sím]	<i>sim</i>	'death'
		[z]	[àzò̀tá]	<i>azɔta</i>	'mess'
<i>Nasals</i>	<i>Bilabial</i>	[m]	[mò̀jè]	<i>mɔye</i>	'bone'
	<i>Labio-Dental</i>	[ɱ]	[lì̀ɱvəlìjé]	<i>lumvalɛye</i>	'water fall'
	<i>Alveolar</i>	[n]	[nó̀]	<i>nɔ</i>	'mouth'

Table 4.1- *continued*

	<i>Retroflex</i>	[ŋ]	[sɛ̀ŋd͡ʒɛ́]	<i>sɛ̀nd͡ʒɛ́</i>	‘rat’
	<i>Palatal</i>	[ɲ]	[ɲím]	<i>ɲim</i>	‘wealth’
	<i>Labial-Velar</i>	[ŋ̠m]	[ŋ̠mgbɛ̀jɛ̀]	<i>ŋgbɛ̀yɛ̀</i>	‘alliance’
	<i>Velar</i>	[ŋ]	[sɔ̀ŋ]	<i>sɔ̀ŋ</i>	‘odor’
<i>Liquid Trill</i>	<i>Alveolar</i>	[r]	[kùrìrì]	<i>kìdìdìdì</i>	‘(very) straight’
<i>Liquid Flap/Tap</i>	<i>Retroflex</i>	[ɽ]	[sòkòɽó]	<i>sòkòdɔ̀</i>	‘(fufu) meal’
<i>Lateral Liquid</i>	<i>Alveolar</i>	[l]	[lí̀m]	<i>lum</i>	‘water’
<i>Approximants</i>	<i>Palatal</i>	[j]	[jósó]	<i>yɔ̀sɔ̀</i>	‘mother-in-law’
	<i>Bilabial</i>	[w]	[wísì]	<i>wɪsɪ</i>	‘sun’
	<i>Glottal</i>	[h]	[hàlú]	<i>halu</i>	‘woman’

A few details must be pointed out about the new phonetic inventory of consonants in Table 4.1, especially as it compares to the one found in the previous literature. The new phonetic inventory confirmed 29 consonantal sounds as opposed to 30 in Lébikaza 1999. The most significant difference between the new inventory and Lébikaza’s is the velar glide [ɣ]. This segment is not attested by the current study in the Kabiye data. Instead, the actual segment that occurs in the data (usually represented by [ɣ] in previous works) is found to be a fully vocalic segment. Therefore, it is discussed together with the vocoids in the revised analysis of vowels, where its phonological status is also discussed in more depth. Another minor detail in the class of liquids also differentiates the current inventory: the alveolar flap [r] of Lébikaza is more appropriately replaced with the retroflex flap [ɽ]. In another respects, the current investigation has confirmed Lébikaza’s observation that Delord’s (1976: 19) dentalized bilabial fricative [ɸ], which is supposedly a phonetic realization of the fricative /f/, is not a segment of Kabiye. As a matter of fact, it has been observed that Kabiye natives

who learn Ewe (a Kwa language of Togo) as second language have difficulty producing the dentalized bilabial fricative in Ewe words.

4.3 Phonological Analysis of Consonants

The phonological analysis of the inventoried consonantal sounds seeks to establish contrasts of consonants in initial, medial, and final positions. Table 4.2 shows consonants distribution in these positions. A dash (-) indicates that the sound being illustrated does not occur in the corresponding position.

Table 4.2 Illustration of Consonants Distribution

Consonant	Initial Position	Medial Position	Final Position
[p]	[pèlɛ́] ‘girl’	-	-
[b]	-	[àbàlú] ‘man’	-
[t]	[tóm] ‘language’	[ké'tíú] ‘peanut’	-
[d]	-	[kùdòǵ] ‘disease’	-
[t̪]	[t̪óm] ‘salt’	-	-
[d̪]	-	[sɛ̀nd̪ɛ́] ‘rat’	-
[k͡p]	[k͡pínɛ̀] ‘animal’	[t͡ʃàk͡pàdà] ‘species of snake’	-
[g͡b]	-	[ɛ̀g͡bám] ‘hunter’	-
[k]	[kójɛ̀] ‘medication’	[jòkíù] ‘to break’	-
[g]	-	[ɛ̀gò̀m] ‘guest’	-
[t͡ʃ]	[t͡ʃàlím] ‘blood’	[k͡pàt͡ʃà] ‘a machete’	-
[ɕ]	-	[kùɕùkà] ‘Sunday’	-
[f]	[fɛ̀ɛ́] ‘shame’	[kífàlùú] ‘the new one’	-
[v]	-	[ɛ̀vɛ̀bú] ‘young man’	-
[s]	[sím] ‘death’	[kísíù] ‘to look back’	-
[z]	-	[àzò̀tà] ‘a mess’	-
[h]	[hàlú] ‘woman’	[là̀hùlòmìjɛ̀] ‘joy’	-
[m]	[mò̀jɛ̀] ‘bone’	[nìmìjɛ̀] ‘rope’	[lím] ‘water’
[ŋ]	[ŋ-véjɛ́] ‘you are not’	[lì̀ŋvəlìjɛ́] ‘water fall’	-

Table 4.2 – *continued*

[n]	[nɔ́ɔ] ‘mouth’	[tànàú] ‘joke’	-
[ŋ]	[ŋɔ́álú] ‘brother’	[sɛ̀ŋɔ́ɛ́] ‘big wild mouse’	-
[ŋ]	[ŋíṃ] ‘wealth’	[kàníŋgà] ‘sand’	-
[ŋm]	[ŋmgbɛ̀jɛ̀] ‘alliance’	[niŋmgbáŋgà] ‘leg’	-
[ŋ]	[ŋgùlúmìjɛ̀] ‘fist’	[tʃéŋgá] ‘line’	[sɔ́ŋ] ‘bad odor’
[r]	-	[járɛ̀] ‘egg’	[kùr̀r̀] ‘(very) straight’
[ɾ]	-	[sòkòɾɔ́] ‘(fufu) meal’	-
[l]	[líṃ] ‘water’	[hàlú] ‘woman’	-
[j]	[jɔ́sɔ́] ‘mother-in-law’	[hɔ́jɛ̀] ‘heart’	-
[w]	[wísi] ‘sun’	[kàwìlási] ‘omen’	-

From Table 4.2, there appears to be strong restrictions on consonants’ distribution. All the consonants, except the nasals [m] and [ŋ], are banned from word-final position, as seen in the rightmost column in Table 4.2. Furthermore, the occurrence of voiced obstruents, as well as the liquid trill [r] and the liquid flap [ɾ] is restricted in word-initial position, at least as occurring in a wordlist. In word-medial position, consonants tend to occur freely, except [p] and [t].

The phonological analysis of consonants will proceed with the analysis of sonorants and finish with obstruents, which represent a more complex case.

4.3.1 The Phonological Status of the Approximants

The glides [j], [w], and [h] constitute the class of approximants due to their articulatory properties. However, the sounds in this class also share an important phonological behavior. They are all known to occur interchangeably in a limited number of words from one Kabiye variety to another. According to Lébikaza (1999: 121), this behavior, which is specific to these sounds, further testifies that they belong

to a same class. Indeed, at the initial of such words, the glottal [h] occurs in one variety of a given word, whereas the palatal [j] occurs instead in another variety (94). A similar shift is also observed between [h] in one variety to [w] in another variety or from [w] to [h] (95). At times, the shift is from [h] to [w] and to [j], depending on the variety (96).

(94)	Variety A	Variety B	
	[h]	[j]	
b.	[hírɛ̀]	[jírɛ̀]	‘name’
a.	[hílíú]	[jílíú]	‘horn’
c.	[híláá]	[jíláá]	‘flute’

(95)	Variety A	Variety B	
	[h]	[w]	
a.	[hòlú]	[wòlú]	‘mouse’
b.	[hóbù]	[wóbù]	‘to gill’
	[w]	[h]	
c.	[wòṅgá]	[hòṅgá]	‘laughter’

(96)	Variety A	Variety B	Variety C	
	[h]	[w]	[j]	
a.	[jóndù]	[wóndù]	[hóndù]	‘song’
b.	[jéndù]	[wéndù]	[héndù]	‘things’

However, all Kabiye varieties contrast the three approximants in word-initial position as in (97).

- (97) /j/ vs. /w/ vs. /h/
- a. [jèlùù] ‘to wander’
 - b. [wèlùù] ‘to incline’
 - c. [hèlùù] ‘to hammer’

The distribution of the three approximants in word-medial and word-final positions is more limited. The palatal [j] and the labial-velar [w] occur in the root, where they contrast as shown by the minimal pair in (98). Both occur also intervocalically after a morpheme boundary in root-initial position, as shown by (99) and (100). The glottal [h], on the other hand, appears intervocalically only after a morpheme boundary and when it is root-initial, as in (101) and (102). The glottal approximant is also in contrast with other consonants in this position. None of the three approximants is found in word-final position under the current analysis (also see the discussion in §1.3.4).

(98) /w/ vs. /j/

- a. [líwú] ‘to dip’
- b. [líjú] ‘the one who dips’

(99) [kì-wíjàð] ‘kingdom’ (from /kì-/ ‘(prefix)’ and /wíj-/ ‘king’)

(100) [kì-jàkù] ‘market’ (from /kì-/ ‘(prefix)’ and /jàb-/ ‘buy’)

(101) [kà-hújàð] ‘diarrhea’

(102) [kì-hèjìù] ‘retaliation’

It is concluded from (97) through (102) that the three approximants are contrastive in Kabiye and, therefore, represent different phonemes as /j/, /w/, and /h/, although they can also occur in free variation relationship across Kabiye varieties.

4.3.2 The Phonological Status of the Liquids

Among the three liquids shown in Table 4.1, the lateral [l] is never in allophonic relationship with any other consonant. The alveolar trill [r] and the retroflex flap [ɽ], on

the other hand, are found to be in allophonic relationship with each other, but also with the retroflex obstruents, [ʈ] and [ɖ].

The distribution of the lateral liquid is as follows. The lateral [l] is excluded from word-final positions, like most of the consonants, and occurs only in word-initial and word-medial positions. In word-initial position, [l] is in phonological opposition to [t] (as the voiceless allophonic variant of [r] and [ʈ] in this position), as illustrated by the minimal pair in (103). The lateral liquid is also in opposition to sonorants such as [j] and [h] in initial position (104). In word-medial position, [l] contrasts with [j] as in (105) and with [ʈ] (or [r]) as in (106).

(103) /l/ vs. [t]

- a. [lèjùù] ‘to be first’
- b. [tèjùù] ‘to flatter’

(104) /l/ vs. /j/ vs. /h/

- a. [lávú] ‘to sacrifice’
- b. [jávú] ‘to call’
- c. [hávú] ‘to fetch’

(105) /l/ vs. /j/

- a. [hèlúù] ‘to hammer’
- b. [hèjùù] ‘to pay’

(106) /l/ vs. [ʈ] vs. [s]

- a. [wàlúù] ‘to widen’
- b. [wàʈúù] ‘to demolish’

The phonological contrasts shown by the minimal pairs in (103) through (106) demonstrate the status of /l/ as a phoneme.

In considering the distribution of the trill [r] and the flap [ɾ], it is observed that both liquids occur interchangeably between vowels, but only the trill occurs in word-final position. Neither occurs word-initially.

The distribution of the trill [r] and the flap [ɾ], as found in this analysis, differs slightly from previous literature. Lébikaza's phonological analysis identified an intervocalic alveolar flap [ɾ] that occurs before front vowels, as in [háráà] 'peasants', whereas before back vowels, the alveolar trill [r] occurs (Lébikaza 1999: 89). The findings of the current study did not indicate any particular relation of back or front vowels to the distribution of these liquids. Rather, it is found that the trill [r] and the flap (which is replaced in this analysis by the retroflex [ɽ]) have an identical distribution between vowels. However, more often, the trill tends to occur (instead of the flap) as a means of emphasis. Unsurprisingly, therefore, the trill occurs mostly in ideophones, which are the type of words serving for emphasis and in which sequential trills serve for even more emphasis.

The examples (107) through (110) illustrate [r] and [ɽ] intervocalically whereas [r] occurring in word-final position is illustrated by (111).

(107) [kéɽè] or [kérè] 'tooth'

(108) [sàɽé] or [sàré] 'frog'

(109) [póɽú] or [póru] 'mosquito'

(110) [kéɽéɽé] or [kéréré] 'ideophone expressing the idea of extreme tiredness'

(111) [kùrìrì] '(very) straight'

The distribution of [ɽ] and [r] indicates that both liquids do not represent separate phonemes; rather, the retroflex flap [ɽ] and the alveolar trill [r] manifest themselves as allophones in free variation.

In (112) and (113), an alternation of [r] and [ɽ] (from now on, both illustrated by [ɽ]) with the retroflex obstruents [t] and [d] is further observed at a morpheme boundary.

(112) a. [tóm] ‘sleep’

b. [mòh-dóm] ‘my sleep’

c. [pò-ɽóm] ‘their sleep’

(113) a. [tèwù] ‘to be beautiful’

b. [mèh-dèwá] ‘I am beautiful’

c. [pèlé 'ɽéwá] ‘The girl is beautiful’

d. [kí-'ɽé'ɽéwù] ‘holy one’

In (112) and (113), both liquids are in complementary distribution with the retroflex stops [t] and [d]. The voiceless [t] occurs only in word-initial position as shown in the (a) examples; medially after a morpheme boundary, the voiced retroflex [d] occurs after a nasal, as in the (b) examples; and [ɽ] (~ [r]) occurs between vowels as in the (c) examples. Of these multiple variants, only the trill [r] is found in final position. It is, therefore, concluded from this complementary distribution that [ɽ] and [r] are allophones that belong to a single phoneme, which *also* has as allophones both [t] and [d]. Since the occurrence of each of these allophones is very restricted and equally predictable, their distribution alone does not decisively indicate which of the four allophones represents the underlying segment. Therefore, extra information is needed.

In §4.3.4 and §4.3.5, where the phonological status of obstruents and voiced and voiceless obstruents alternations are discussed, the voiced /d/ is shown to be the phoneme from which the retroflex obstruents [ɖ] and [ɗ] and the liquids [ɽ] and [ɹ] are derived. The rule that derives all four allophones is shown.

(114) Rule 12

$$/d/ \text{ -----} > \left\{ \begin{array}{l} [ɖ] / \# \# _ \\ [ɗ] / /N/ _ \\ [ɽ] / V _ V \\ [ɹ] / _ \# \# \end{array} \right.$$

Understanding the phonetic characteristics of the retroflex obstruents [ɖ] and [ɗ] can help explain the allophonic relationship between these obstruents and the liquids [ɽ] and [ɹ] in Kabiye. A detailed discussion by Lébikaza (1999: 92-93) highlighted the singular articulatory characteristics of the retroflex consonants [ɖ] and [ɗ], which qualify them as obstruents, on the one hand, but also show them similar to liquids on the other. According to Lébikaza, though the retroflexes [ɖ] and [ɗ] are correctly classified as obstruents, some of their characteristics also confer upon them an intermediary status between obstruents and liquids. These characteristics, which distinguish the retroflex obstruents [ɖ] and [ɗ] from the non-retroflex obstruents [t] and [d] in Kabiye, have mainly to do with the part of the tongue involved in the articulation of each of both series of obstruents. Although the articulation of both series of consonants involves the stoppage of oral airflow, this stoppage is accomplished with the tip of the tongue in the

case of the non-retroflex obstruents [t] and [d] and the back of the tip of the tongue for the retroflex obstruents [ɖ] and [ɗ]. However, another characteristic also sets the retroflex obstruents apart from all the other obstruents in Kabiye. Lébikaza further argues that the retroflex obstruents are articulated with a lesser tension than the non-retroflex obstruents such as [t] and [d]. This distinction, he writes, has already been shown in African languages in general by Ladefoged (1962: 13ff), who characterizes the tension of the muscles as weaker (less energy) in the production of the retroflex obstruents than in the production of the non-retroflex ones. Lébikaza closes his arguments by further pointing out that the articulation of the retroflex obstruents appears to require more muscle tension when compared to the trill [r] in Kabiye.

This discussion shows that only a subtle shift in the articulation allows to go from the production of the retroflex obstruents to the production of the liquids. One mainly passes from the retroflex obstruents [ɖ] and [ɗ] to the retroflex flap [ɗ̥] by using lesser muscle tension; then, just uncurling the tip of the tongue allows a shift from the retroflex point of articulation to the alveolar one, for the trilling, which produces [r] instead. The subtlety of this shift seems to allow consonants of otherwise different subclasses to be allophones of a same phoneme in Kabiye. This shift from *retroflex* to *alveolar* appears to be corroborated by the fact that Kabiye does not use the retroflex liquid and the alveolar liquid contrastively.

4.3.3 The Phonological Status of Nasals

The phonological analysis of nasals ultimately shows that only three of the nasals inventoried at the phonetic level are represented in the phonological system. However, not all of the nasals inventoried at the phonetic level have their underlying segment represented in Table 4.1. As will be argued below, an underspecified nasal archiphoneme also occurs underlyingly in Kabiye. Minimal pair contrasts and a study of the environments in which the phonetic nasals [m], [n], [ŋ], [ɲ], [ɳ], [ɲ̄m], and [ɳ] occur allow us to determine each nasal segment's phonological status.

The illustration of consonants in Table 4.2 (page 125) has indicated that all the nasals occur freely in word-initial and word-medial positions, but only [m] and [ŋ] occur in word-final position. However, the phonological analysis has indicated that only the nasals [m], [n], and [ɲ] can be contrasted minimally in initial position, as shown by (115), and in medial positions, as in (116). The bilabial [m] further shows a contrast with [ŋ] in word-final position, as in (117).

(115)

- a. [máŋ] 'rice (PI)'
- b. [náŋ] 'cows'
- c. [ɲáŋ] 'bitterness'

(116)

- a. [kámási] 'limits'
- b. [kánási] 'hangers'
- c. [káɲási] 'mean persons'

(117)

- a. [tóm] ‘language, story’
- b. [tón] ‘bows’

While the phonological status of /m/, /n/, and /ɲ/ can be deduced from the contrasts in (115) and (116), demonstrating the phonological status of the other nasals, including the velar nasal [ŋ], is a more complex process, as further facts about these nasals require consideration.

In earlier accounts, the status of the velar nasal [ŋ] was unsettled, alternating between phoneme and allophone. According to most of the studies, the velar nasal [ŋ] represents a phoneme /ŋ/ in Kabiye (Delord 1976, Paaluki 1995, Kassan 1996, CLNK & SIL-Togo 1998, Roberts 2002 and 2003). The studies of Lébikaza (1985 and 1999), on the other hand, adopt a different position, which proposes that [ŋ] is not a phoneme, but an allophone of /n/. The results of the current investigation, as preliminarily presented in Padayodi 2008, side more with the view of Lébikaza. Despite the apparent contrast of [ŋ] with [m] in word-final position as in (117), which at first, seems to point to a contrastive status of the velar nasal, the phonological status of the velar nasal cannot be decided based on this sole contrast, since this segment could also represent any of the other nasals that do not occur in this position. Ultimately, the hypothesis of a phonemic status of the velar nasal is dismissed in light of the following discussion of the various alternations determined in nasals, including the velar nasal, in word initial, medial, and final positions.

Nasals are often homorganic to the consonant they precede. This includes nasals that occur as prefixes in word-initial positions, as illustrated by the (a) examples in (118) through (123), and nasals occurring in word-medial positions, as illustrated by the (b) examples in (118) through (123) and by (124).

(118) a. [m̀b̀d̀m̀] ‘cassava’

b. [k̀m̀b̀k̀] ‘dusty dirt’

(119) a. [ǹz̀l̀m̀j̀] ‘tongue’

b. [t̀d̀] ‘beard’

(120) a. [ŋ̀g̀l̀m̀j̀] ‘fist’

b. [t͡ʃ̀k̀] ‘sieve’

(121) a. [ŋ̀m̀b̀m̀] ‘termite’

b. [ǹŋ̀m̀b̀àg̀] ‘leg’

(122) a. [j̀d̀j̀] ‘beak’

b. [k̀t̀s̀l̀] ‘swirl’

(123) a. [ŋ̀d̀] ‘spatula’

b. [k̀d̀] ‘lamp’

(124) [k̀v̀l̀] ‘young chicken’

The behavior of the pre-consonantal nasals in (118) through (124) indicates that the nasal segment underlying them is an archiphoneme; this for two reasons. First, it is impossible to establish a relationship between the segment that underlies the pre-consonantal nasals and any of the nasal phonemes previously determined – /m/, /n/, /ɲ/ – nor with any of the other nasals in the phonetic inventory. Second, the nasal segment, which underlies the pre-consonantal nasals, appears to be only specified for the feature

[+nasal] and not for place of articulation. In context, this underlying nasal shares the place of articulation of the following consonant to be realized as the bilabial nasal [m] before a bilabial consonant (as in (118)), as the alveolar nasal [n] before alveolar consonants (as in (119)), as the velar nasal [ŋ] before velar consonants (as in (120)), as the labial-velar nasal [ɱ] before labial-velar consonants (as in (121)), as the palatal nasal [ɲ] before palatal consonants (as in (122)), as the retroflex nasal [ɳ] before a retroflex consonant (as in (123)), and as the labio-dental nasal [ɹ̥] before labio-dental consonants (as in (124)). Therefore, this underlying segment is determined as a nasal archiphoneme and represented by /N/.

It follows that in the context preceding another consonant, all seven phonetic nasals [m, n, ŋ, ɱ, ɲ, ɳ, ɹ̥] are derived from the nasal archiphoneme through a homorganic assimilation rule, which is formulated as follows:

(125) Rule 13: Nasal archiphoneme homorganic assimilation rule

$$/N/ \quad \text{-----} > [\alpha \text{ place}] / ___ C$$

[α place]

Archiphonemes, attested in languages throughout the phonological literature, are commonly represented with upper case letters, as an indication of their underspecified nature. One such example is the nasal archiphoneme reported by Burquest at syllable-final in Ashéninka (Payne 1981), which is remarkably similar to the case of Kabiye.

Burquest writes:

Nasal consonants /m/ and /n/ contrast syllable initially and intervocalically in Ashéninka. Preceding obstruents, however, only nasal

consonants at the same place of articulation as the following obstruent occur. [...] Several native speakers were taught to write syllable-initial nasals *m* and *n* as in *mapi* ‘rock’ and *ana* ‘black dye’. They were also taught to write *n* before *t* for the syllable final nasal as in *antami* ‘jungle’. When writing the syllable final nasal before *p*, however, (as in *ampe* ‘cotton’) they chose *n* (*anpe*). They later learned to write *m* before *p*, as it is in Spanish, and each of them then consistently began to write *m* also before *t* (*amtami*). We may take these facts as external evidence that at some underlying level syllable-final nasals, although they vary in phonetic form, are in fact the same segment, not derived from the syllable-initial nasals which are specified for place of articulation. The fact that the previously mentioned native speakers wrote this consonant with *n* and then later, with equal facility, wrote the same letter with *m* in all environments we take to be compelling evidence that this nasal should be underspecified for place of articulation, i.e., an archiphoneme. The phonemic transcription with archiphonemes of some of the data [...] would be: /aNpe/ ‘cotton’, /aNtami/ ‘jungle, and /iNki/ ‘peanut’ (Burquest 2006: 67–68).

The existence of a nasal archiphoneme in Kabiye was first mentioned by Delord (1976: 19-22), but never again in any of the studies by subsequent researchers on this language. Delord, indeed, noticed that nasals preceding a consonant are articulated at the same place as the consonant they precede. However, though Delord clearly states that these manifestations point to a nasal archiphoneme /N/, his understanding of the nature of this nasal archiphoneme was slightly different from its current view in this research. In Delord’s analysis, the nasal archiphoneme is not part of the phonemic consonant system, but represents only a neutralization of the nasal phonemes /m/, /n/, ɲ/, and /ŋ/³⁶. From the

³⁶ Note: The velar nasal is not a phoneme under the current analysis.

perspective of the current study, it is argued that the contrast between nasals is lost in this specific position, except for the phoneme /m/ (the case of which is presented later in this discussion); therefore, a nasal archiphoneme should be posited as the underlying segment. This segment is a *different* nasal than any of the pre-established nasal phonemes /m/, /n/, and /ɲ/, which contrast pre-vocally. The nasal archiphoneme /N/ is a phonemic segment of its own.

However, not all cases of neutralization involving nasals in Kabiye should be analyzed with an underspecified segment. The palatal nasal /ɲ/ of the morpheme of the 2nd person singular pronoun (2Sg) undergoes similar alternations as the nasal archiphoneme, when it occurs in subject position before a root-initial consonant. As is mostly the case for subject and object pronouns in this language, the 2nd person singular pronoun occurs in its complete form as the free morpheme [ɲá] ‘you’ in emphatic use (Lévikaza 1999: 453 & ff.), as shown in (126) and (127).

(126) /ɲÁ ání/ [ɲá ání] ‘Who are you?’

2Sg who

(127) /ɲÁ kòò tʃíné/ [ɲá kòò tʃíné] ‘You, come here!’

2Sg come here

In non-emphatic use, the 2nd person singular pronoun is prefixed to the verb (as subject pronoun) or suffixed to the verb (as object pronoun), and is realized as an elliptic form, reduced to the palatal nasal only. Preceding a root-initial vowel, this segment surfaces as [ɲ], as 0in (128) and (129).

(128) /ɲÁ ès -ɪ -'jÈ/ [ɲé 'ésíjè] 'your eye'
 2Sg eye EpV -5SgT3

(129) /ɲÁ àjab -à/ [ɲá àjàbà] 'your bananas'
 2Sg banana -6PIT3

Preceding a root-initial consonant, however, it varies: like the archiphoneme describe above, this palatal nasal surfaces as a nasal that is homorganic to the following consonant. It is therefore realized as any of the seven phonetic nasals. The following are the manifestations of the palatal nasal /ɲ/ in the 2nd person singular pronoun.

(130) /ɲ/ becomes [m] before the bilabials /m/ and /b/ ([p] and [b]) as in:

a. /ɲÁ màb -á/ [ɲmàbá] 'you beat'
 2Sg beat -Acc

b. /ɲÁ bòz -ɪ -á/ [ɲbòzàá] 'you asked'
 2Sg ask -EpV -Acc

(131) /ɲ/ becomes [n] before the alveolars /n/, /t/, /d/, /s/, /z/ and /l/, as in:

a. /ɲÁ ná -w -á/ [ɲnàwá] 'you saw'
 2Sg see - EpC -Acc

b. /ɲÁ tèm -á/ [ɲdèmá] 'you finished'
 2Sg finish -Acc

c. /ɲÁ sé -w -á/ [ɲzèwá] 'you ran'
 2Sg run - EpC -Acc

d. /ɲÁ zèt -í -á/ [ɲzètáà] 'you cut'
 2Sg cut -EpV -Acc

e. /ɲÁ lèb -á/ [ɲlèbá] 'you are lost'
 2Sg lose -Acc

(132) /ɲ/ becomes [ɲ] before the labio-dentals /f/ and /v/, as in:

- a. /ɲÁ fèm -á/ [ɲvèmá] ‘you awoke’
 2Sg awake -Acc
- b. /ɲÁ vèt -ɪ -á/ [ɲvètáá] ‘you fanned’
 2Sg fan EpV -Acc

(133) /ɲ/ becomes [ɲ] before the retroflex /d/ ([ɖ], [ɗ]), as in:

- /ɲÁ dɛ -w -á/ [ɲdɛwá] ‘you are beautiful’
 2Sg be^beautiful -EpC -Acc

(134) /ɲ/ becomes [ɲ̠m] before the labial-velar stops /k̠p/ and /g̠b/ and the approximant

/w/, as in:

- a. /ɲÁ k̠pèm -á/ [ɲ̠m̠g̠bèmá] ‘you went home’
 2Sg go^home -Acc
- b. /ɲÁ g̠bèlek -ɪ -á/ [ɲ̠m̠g̠bèlèkàá] ‘you learned’
 2Sg learn - EpV -Acc
- c. /ɲÁ wàb -á/ [ɲ̠mwàbá] ‘you won’
 2Sg win -Acc

(135) /ɲ/ becomes [ɲ] before the velar stops /k/, /g/ and the glottal /h/, as in

- a. /ɲÁ kòm -á/ [ɲgòmá] ‘You have come’
 2Sg come -Acc
- b. /ɲÁ gít -í -á/ [ɲgítáá] ‘You returned’
 2Sg return -EpV -Acc
- c. /ɲÁ hà -w -á/ [ɲhàwá] ‘you gave’
 2Sg give -EpC -Acc

(136) /ɲ/ becomes [ɲ] before the palatals /ɲ/, /j/, /tʃ/ and /ɕ/, as in:

- a. /ɲÁ ɲàs -ɪ -á/ [ɲɲàsáá] ‘you bit’
 2Sg bite -EpV -Acc

b.	/ɲÁ	jàb	-á/	[ɲjàbá]	‘you bought’	
	2Sg	buy	-Acc			
c.	/ɲÁ	tʃij	-í	-á/	[ɲtʃijáà]	‘you tore’
	2Sg	tear	-EpV	-Acc		
d.	/ɲÁ	ɕʒèt	-ɪ	-á/	[ɲɕʒètáá]	‘you lied’
	2Sg	lie	-EpV	-Acc		

The data in (130) – (136) show that the nasal /ɲ/, occurring in pre-consonantal position (only as morpheme of the 2nd person singular pronoun), behaves exactly the same way as the nasal archiphoneme. However, unlike the archiphoneme, which is not specified for place of articulation, the underlying nasal of the 2nd person singular pronoun is specified for a palatal place of articulation. Therefore, when the surface-level nasals [m ɱ n ɲ ɲ̠ ɲ̡] represent the 2nd person singular pronoun, as shown in (130) through (136), they are all derived from the palatal nasal /ɲ/, instead.

The rule formalized in (137) derives the seven surface nasals from the underlying palatal nasal /ɲ/ of the 2nd person singular pronoun /ɲÁ/, occurring as prefixes.

(137) Rule 14 – Palatal nasal homorganic assimilation rule

$$/ɲ/ \text{ -----} > [\alpha \text{ place}] \left/ \begin{array}{l} \text{---} \# C \\ [\alpha \text{ place}] \end{array} \right.$$

Parallel to the tendency of surface-level nasals to share the place of articulation of the consonant they precede, a bilabial nasal is also seen preceding a consonant with which it is not homorganic. This bilabial nasal is illustrated by (138), (139), and (140).

(138) [sàm̀tù] ‘praises’

(139) [ɲà̀m̀sìù] ‘to shake’

(140) [sòrntù] ‘bean flour paste’

Unlike the bilabial nasal seen in (118), which derives from the nasal archiphoneme, the pre-consonantal bilabial nasal illustrated in (138) through (140) shows resistance to homorganic assimilation, indicating that this bilabial nasal derives from the underlying bilabial nasal /m/. It is further observed that though both the bilabial nasal in (138) through (140) and the bilabial nasal derived from the nasal archiphoneme occur pre-consonantly, their distribution in the word is not exactly the same: the bilabial nasal from the archiphoneme in (118) occurs pre-consonantly in the root whereas the bilabial nasal in (138) through (140) occurs in root-final position before the consonant of the suffix. The nasal underlying the pre-consonantal bilabial nasal in root-final position is hence shown to be the bilabial phoneme /m/, which is already known to occur in initial, medial, and final positions.

Affixation cases, however, also tend to support that the pre-consonantal bilabial phoneme /m/ occurring in root-final position does assimilate to the point of articulation of the following consonant of the suffix, but differently than the pre-consonantal bilabial nasal derived from the nasal archiphoneme. As a matter of fact, from (138), (139) and (140), it appears that sequences of a bilabial nasal followed by a non-homorganic consonant such as m[t] and m[s], are allowed. At the same time, in similar affixation cases, it is unexpectedly seen that neither of the sequences *m[k] and *m[g] is allowed (see (145) and (146), below). However, it is also a known fact that the sequence [ŋg] is allowed (see [ŋg] or [ŋ] in cases of optional erasure of [g] in non-final position after [ŋ]

as in [sàṅgàá] or [sàṅàá] ‘was praising’ from /sàm-/ ‘to praise’, [kpèṅgàá] or [kpèṅàá] ‘was going home’, from /kpèm-/ ‘go home’, etc.). From these observations, there seems to be an indication that the context in which the root-final bilabial nasal is assimilated to the place of articulation of a following consonant is more specific. It is argued that the assimilation of the bilabial nasal /m/ is conditioned, not just by any consonant, but by the presence of a following voiced consonant. This interpretation appears to be supported by other examples, such as [ègḁm] ‘guest’ vs. [ègḁ́n-dù] ‘status as guest’, [ègbám] ‘hunter’ vs. [ègbá́n-dù] ‘hunting’, [sèm-á] ‘rats’ vs. [sèṅ-dé] ‘rat’, [lím] ‘water’ vs. [lìṅvàlijé] ‘water fall’, or [sùṅ-zúm-ìjè] ‘cockroach’.

The rule that accounts for the assimilation of the underlying nasal /m/ to the point of articulation of the following voiced consonant is formalized as in (141).

(141) Rule 15 – Rule of assimilation of the bilabial nasal

$$/m/ \text{ -----} > [\alpha \text{ place}] / \text{---} \# \left[\begin{array}{c} C \\ + \text{voice} \\ \alpha \text{ place} \end{array} \right]$$

The rule that accounts for the optional erasure of the velar stop [g] after [ŋ] is also formulated as in (142).

(142) Rule 16 – Erasure of the velar stop [g] after the velar nasal

$$[g] \text{ -----} > \emptyset / [ŋ] \text{ ---} Y$$

(with Y representing any segment)

In word-final, the only nasals that occur, [m] and [ŋ], represent various morphemes in this position. The bilabial nasal represents the elliptic form of the object 1st person singular pronoun, as shown in (143), or a simple root-final nasal, as in (144). The velar nasal, on the other hand, can represent up to four different morphemes in word-final position. It can represent the suffixed aspect marker of the Inaccomplished in verbal paradigms, as shown in (145), the root-final nasal in class-3 (3SgT2) nouns, as in (146), the suffixed plural marker of class-4 (4PIT2) nouns, as in (147), or the object 2nd person singular pronoun, as seen in (148).

(143) /nÁ ná mÁ/ [n-ná-m] ‘you saw me’
 2Sg see^Acc 1Sg

(144) /kpèm -Ù/ [kpém] ‘to go home’
 go^home -INF

(145) /kpèm -kÌ/ [kpéŋ] ‘goes home’
 go^home -Inacc

(146) /kimelem -kÛ/ [kimeleŋ] ‘idiot’
 idiot -3SgT2

(147) /kimelem -’N/ [kimelem-í-ŋ] ‘idiots’
 idiot -4PIT2

(148) /mÁ ná nÁ/ [mà-ná-ŋ] ‘I saw you’
 1Sg see^Acc 2Sg

It is determined from these data that the bilabial nasal is derived from a single underlying segment in word-final position while the velar nasal can be derived from three different underlying segments, depending on the morpheme it represents. In (143),

the bilabial nasal representing the suffixed object 1st person singular pronoun in final position, is determined to be derived from /m/ in the full form [má] ‘me’ of this pronoun, as illustrated. The root-final bilabial nasal in (144) too can be derived from an underlying /m/, as illustrated. It is advocated that the underlying root-final bilabial nasal is maintained in such forms, even after the vowel of the suffix is lost. Other paradigms such as forms of the Accomplished aspect, where the underlying bilabial nasal also surfaces as [m] before the marker as in [kpèm-á] ‘went home’, clearly support this analysis.

In verbal paradigms of the Inaccomplished aspect and in class-3 (3SgT2) nouns, as seen in (145) and (146), respectively, the word-final velar nasal can be derived medially from the sequence *nasal + velar stop* (which is realized phonetically as [ŋg] or [ŋ] after erasure of the velar stop in word-final position). This sequence is created by the suffixation of the aspectual morpheme of the Inaccomplished known as /-kì/, and the class-3 noun marker, known as /-kù/ (Lévikaza 1999, 1.2.8). It is argued, following Lévikaza (1999), that in these roots, the erasure of the word-final velar stop occurs following the velarization of the bilabial nasal. Hence, in both cases, the velar nasal is derived in medial position from the root-final bilabial /m/ and the suffix-initial velar consonant /k/ according to a rule that assimilates nasals to the point of articulation of the following consonant. Both affixation cases are illustrated by the derivation steps in

(149) and (150), respectively³⁷.

(149) /kɔ̀pɛ̀m -kɪ̃/ --> *[kɔ̀pɛ̀mkɪ̃] --> *[kɔ̀pɛ̀mgɪ̃] --> *[kɔ̀pɛ̀ŋgɪ̃] -->
 *[kɔ̀pɛ̀ŋɪ̃] --> [kɔ̀pɛ̀ŋ] ‘goes home’

(150) /kɪ̃mɛ̀lɛ̀m -kÙ/ --> *[kɪ̃mɛ̀lɛ̀mkÙ] --> *[kɪ̃mɛ̀lɛ̀mgÙ] --> *[kɪ̃mɛ̀lɛ̀ŋgÙ] -->
 *[kɪ̃mɛ̀lɛ̀ŋÙ] --> [kɪ̃mɛ̀lɛ̀ŋ] ‘idiot’

Supporting evidence of this analysis comes from paradigms of other verb root types in the Inaccomplished and from the forms of other class-3 nouns where the morpheme of the Inaccomplished aspect surfaces as shown in (151) and (152).

(151) /È- wòb -kɪ̃/ [èwókɪ̃] ‘s/he goes’
 3Sg go -Inacc

(152) /là -kÚ / [làkÚ] ‘wilderness’
 wilderness -3SgT2

In class-4 nouns illustrated by (147) and the case of the 2nd person singular object pronoun illustrated by (148), the word-final [ŋ] can be derived from the plural class marker, in the first case, or from the palatal nasal /ɲ/ of 2nd person singular pronoun, in the second case. The plural noun class marker is determined as a nasal suffix that is not specified for place of articulation. It can therefore be assumed that the underlying nasal

³⁷ Apocope of final vowels also occurs in these examples following two rules formulated in Lébikaza 1999:82 as:

Rule 1: $\begin{bmatrix} /i/ \\ /ɪ/ \end{bmatrix} \text{-----} > \emptyset /[\eta] \text{---}$

Rule 2: /u/ -----> $\emptyset /[\text{m}] \text{---}$

that occurs as a noun suffix is also the nasal archiphoneme /N/³⁸, earlier determined to occur in prefixes.

It has, hence, been shown that there is a phonetic neutralization of the realizations of the nasal archiphoneme and the palatal nasal phoneme in word-final position, both of which surface as the velar nasal [ŋ]. In both cases, the velar nasal is derived through a single phonological rule that imposes a velar realization to the palatal nasal /ɲ/ and the nasal archiphoneme /N/ in word-final position. This rule is formulated as follows:

(153) Rule17 – Rule deriving the velar nasal in word-final position

$$\begin{bmatrix} /N/ \\ /ɲ/ \end{bmatrix} \text{ -----} > [ŋ] / __ \#\#$$

It is concluded from this discussion that of the nasals appearing in the phonetic inventory of Kabiye (Table 4.1), only /m/, /n/, and /ɲ/ have a phonemic status, but the phonemic system also includes a nasal archiphoneme /N/, underspecified for place of articulation.

³⁸ Lébikaza (1999: 118, footnote 7) derives the class-4 (4PIT2) noun marker in Kabiye from /n/ based on a parallel to the class marker found in Tem. According to Lébikaza, this class marker has kept its complete form *-ni* in Tem, which is a close relative of Kabiye. Within Kabiye language itself, however, there is no way of determining today that this class marker is underlyingly an alveolar nasal or any of the other nasal phonemes. It is determined as only a nasal, which is not clearly specified for place of articulation.

4.3.4 The Phonological Status of Obstruents

The first step toward establishing the phonological status of obstruents is the test of minimal pairs and near-minimal pairs, which seeks to contrast these segments in word-initial, word-medial, and word-final positions. But distributional restrictions on Kabiye obstruents do not allow minimal pair contrasts for most of the obstruents. Therefore, it is mainly through a consideration of other phonological factors that a decision can be made as to which of the consonantal phones are attested in the phonemic system.

From the overall distribution of consonants shown in Table 4.2, there appeared to be a strong phonological restriction on the distribution of obstruents, which include the stops [p], [b], [t], [d], [t̪], [d̪], [k], [g], [kp̪], [gb̪], the fricatives [s], [z], [f], [v], and the affricates [tʃ] and [dʒ]. No obstruent occurs in word-final position. In utterance-initial positions (i.e., positions that coincide with the beginning of a sentence, the beginning of a word occurring after a pause in a sentence, or the beginning of a word occurring in isolation, as in a wordlist), only voiceless obstruents are found. The examples in (154) through (157) show minimal contrasts between the voiceless obstruents in initial positions, as occurs in a wordlist.

(154) [p] vs. [f] vs. [k] vs. [kp̪]

- a. [pèdúù] ‘to sell’
- b. [fèdúù] ‘to sink (to the ground)’
- c. [kèdúù] ‘to tell’
- d. [kp̪èdúù] ‘to spill’

(155) [t] vs. [t̪]

- a. [tóm] ‘language’
- b. [tóm] ‘salt’

(156) [p] vs. [t] vs. [k] vs. [s]

- a. [pùlúù] ‘to make porridge’
- b. [tùlúù] ‘to haul’
- c. [kùlúù] ‘to uncover’
- d. [sùlúù] ‘to close’

(157) [t] vs. [k] vs. [tʃ]

- a. [tùjúù] ‘to push forward’
- b. [kùjúù] ‘to strain out’
- c. [tʃùjúù] ‘to push with a stick’

In medial positions, both voiced and voiceless obstruents occur. However, a minimal contrast can be established for only a few obstruents in these positions. (158), (159), and (160) illustrate the possible minimal contrasts of obstruents in word-medial position.

(158) [b] vs. [t]

- | | |
|-------------------------|---------------------|
| a. [wábù] ‘to win’ | c. [nfbù] ‘to trap’ |
| b. [wátù] ‘goose bumps’ | d. [nítù] ‘grass’ |

(159) [t] vs. [k]

- a. [jòtùù] ‘to smash’
- b. [jòkùù] ‘to break’

(160) [t] vs. [d] vs. [z] vs. [s]

- | | |
|--------------------------|----------------------------------|
| a. [wàtùù] ‘to crush’ | e. [fètùù] ‘to fan’ |
| b. [wàdùù] ‘to overflow’ | f. [fèdùù] ‘to sit on the floor’ |
| c. [wàsùù] ‘to boil’ | g. [pìsùù] ‘to return’ |
| d. [wàzùù] ‘to benefit’ | h. [pìzùù] ‘to succeed’ |

The following can be stated of the consonant contrasts just illustrated. While the

minimal contrasts in (154) through (157) allow to deduce that each of the voiceless obstruents illustrated represents a separate phoneme, these contrasts do not determine that these voiceless consonants are the phonemic segments, since they could also represent voiceless allophones of potential voiced phonemes in initial position. However, a possible contrast between obstruents that are only differentiated by voicing (such as [p] vs. [b], [t] vs. [d], [k] vs. [g], etc.) will allow to posit both the voiceless consonants and their voiced counterparts as contrastive segments. As seen, such a contrast is only possible in word-medial position for the alveolar obstruents as in (160), which illustrates [t] and [d] in (a) vs. (b), and (e) vs. (f) and the alveolar fricatives [s] and [z] in (c) vs. (d) and (g) vs. (h). Of all the obstruents, therefore, only /t/, /d/, /s/, and /z/ can definitively be posited so far as contrastive segments. For the rest of the obstruents, further investigation is needed to determine their phonological status. Since it is in medial positions that both voiced and voiceless obstruents occur, these are key positions to investigate.

Despite a lack of minimal pair contrasts for most consonants in medial positions, it is further observed that almost all the voiced and voiceless obstruents can have similar distributions in medial positions. Both voiced and voiceless obstruents occur in the bare root, and often between vowels as in (161) through (167). This is also attested in loan words into Kabiye as illustrated by (168) to (171). Both voiced and voiceless obstruents can also occur after a nasal in the simple root as shown by (172), (173) and (174).

- (161) [tʃááfé́lá] ‘turtles’
- (162) [tòòvèní̀m] ‘truth’
- (163) [kà̀tʃáá́lá] ‘hut’
- (164) [kò̀ɕóà] ‘flea’
- (165) [kᵻ́pá'tʃáá] ‘(proper name for male twin)’
- (166) [ná'káú] ‘grasshopper’
- (167) [tʃà̀kᵻ́pàdà] ‘(species of snake)’
- (168) [káᵻ́nɪ̀dà] ‘carpenter (from the English *carpenter*)’
- (169) [tʃó̀gótò] ‘doctor (from the English *doctor*)’
- (170) [tʃótʃì] ‘church (from the English *church*)’
- (171) [sò̀sòɕà] ‘soldier (from the English *soldier*)’
- (172) [tʃè̀ŋmᵻ́bɛ́] ‘starch’
- (173) [à̀ŋɕáú] ‘cunning person (proper name)’
- (174) [kà̀ŋtʃúólàá] ‘swirl’

In medial positions, after a morpheme boundary, two seemingly opposed tendencies are observed in the occurrence of obstruents. Both voiced and voiceless obstruents also occur after a morpheme boundary. This is observed in words showing root reduplication (175) or after prefixes and other morphemes as shown in (176) through (185).

- (175) a. [tʃò̀-ɕó] ‘traditional priest’
 b. [tʃá́-tʃá́-ɾɛ́] ‘grasshopper’
 c. [kò̀-kò̀-ɾɛ́] ‘gourd’

- (176) a. [à-zún'ná] 'dirt'
 b. [á-sónúù] 'nursing woman'
 c. [á-zóótí] '(proper name)'
 d. [á-vètèú] 'toad'
 e. [á-tòndó] 'dragonfly'
 f. [á-kpàdájú] 'old person'
- (177) [kí- fàlì -ú] 'new one'
 Adj- new -3SgT2
- (178) [kí- 'kízí -sì] 'refused ones'
 Adj- refuse -8PIT4
- (179) [kà- à- tʃiúdáà] 'unshakable'
 Pref- NEG- shake
- (180) [kà- à- kizàà] 'non-refused'
 Pref- NEG- refuse
- (181) [kà- à- gisàà] 'not looking back'
 Pref- NEG- look^back
- (182) [pà- à- tʃiúdi -ù] 'they don't move'
 they- NEG- move -Inacc
- (183) [pà- à- dʒètì -ú] 'they don't lie'
 they- NEG- lie -Inacc
- (184) [pà- à- kizà -á] 'they had refused'
 they- Anter- refuse -Acc
- (185) [pà- à- gisà -á] 'they had looked back'
 they- Anter- look^back -Acc

However, root-initial obstruents appear to alternate also as voiceless at utterance-initial and voiced after a morpheme boundary. The (a) versus (b) examples in (186) through (188) illustrate this case.

- (186) a. [tóm] ‘speech, language’
 b. [kàbìjè dóm] ‘Kabiye language’
- (187) a. [kóm] ‘to come’
 b. [è-gòm] ‘guest’
- (188) a. [tʃèjíù] ‘to bother’
 b. [kì-ɕèjìù] ‘obligation’

Despite the occurrence of obstruents as either voiced or voiceless after a morpheme boundary as shown earlier in (175) through (185), the data in (186) through (192) seem to also indicate that utterance-initial voiceless obstruents are in complementary distribution with their voiced counterparts after a morpheme boundary. However, this alternative interpretation will not be entertained under the current analysis as it will be proven untenable in §4.3.5, where the alternations of voiced and voiceless obstruents after a morpheme boundary are explained.

The bilabials [p] and [b] and the retroflexes [t] and [d] have a distribution that differs slightly from the other obstruents. Like the other obstruents, the voiceless [p] and [t] occur in utterance-initial positions (specified above), as illustrated by the wordlist style examples in (189)a, (190)a, and (191)a. But in medial positions, it is exclusively their voiced counterparts [b] and [d], that are found, whether after a morpheme boundary, as in (189)b, (190)b, (191)b, and (192), or in the simple root as in (193) and (194).

- (189) a. [tóm] ‘salt’
 b. [mòh-dóm] ‘my salt’

- (190) a. [pólú] ‘daughter-in-law’
 b. [è-bólú] ‘his daughter-in-law’
- (191) a. [pìzìù] ‘to succeed’
 b. [kàà-bìzàà] ‘incapable’
- (192) [à-bàlú] ‘a man’
- (193) [tòbùú] ‘bottom’
- (194) a. [sèṅḍḍé] ‘rat’
 b. [tʃàṅḍàwú] ‘queue’

It appears that [p] and [b] are in complementary distribution, as are [t] and [d]. It can therefore be inferred that the voiceless [p] and the voiced [b] are allophones of a single phoneme, and the voiceless retroflex [t] and voiced [d] are also allophones of a single phoneme. However, from the distribution of the segments alone, it is not obvious which of the voiced or the voiceless allophones represent the underlying segments. Therefore, there is a need for further information before that decision can be made.

From the distribution of obstruents in medial positions, it appears that there are voiced and voiceless obstruents occurring in similar or identical environments, which is compelling evidence that there exist underlying voiced and voiceless obstruents in Kabiye. The data in (158) – (160) have shown that voiced and voiceless obstruents occur medially in the root, where some voiceless obstruents can be contrasted to their voiced counterparts through minimal pairs, as seen in (160). The data in (161) – (174) have further shown that though most voiceless obstruents and their voiced counterparts cannot be contrasted with minimal pairs in the root, they occur in similar environments. Similarly, in medial positions after a morpheme boundary, (175) – (185) have shown

that obstruents occur also contrastively as voiced or voiceless. But in medial contexts, exception must be made for the bilabial obstruents and the retroflex obstruents, for only the voiced [b] and [d] occur in the simple root and after a morpheme boundary; on the other hand, the voiceless [p] and [t] are found exclusively in utterance-initial position (see (189) – (194)).

The obstruents of Kabiye do not seem to behave the way segments do in most languages. It is well known, cross-linguistically, that contrasts are usually found word-initially more than in any other position (Beckman 1997, Garr 1986, and others). In the case of Kabiye, it is an established fact (from (154) through (185), above) that contrasts occur only in medial positions, with all or most obstruents banned from marginal positions. The existence of minimal pairs that contrast the alveolar obstruents /t/ vs. /d/ and /s/ vs. /z/ only in word root medial position demonstrates this fact unequivocally. These contrasts are also an indication that there is a strong possibility of other underlying voiced and voiceless obstruents, all or some of which could also constitute pairs that contrast only in voicing, even though minimal pairs could not be established for these obstruents. Critically, in medial positions (within the word root and after a morpheme boundary), we find voiced obstruents and their voiceless counterparts, occurring contrastively in identical environments, indicating that they represent distinct phonemes. The Forms with reduplicated roots in (175) and those in (179) through (185), in which the root initial obstruents occurring in identical environments are either voiced or voiceless, demonstrate this contrast. In that sense, (176)b. and (176)c., (180) and (181), (182) and (183), (184) and (185), for instance, constitute near-minimal pairs.

These facts confirm a contrastive use of more voiced and voiceless obstruents in medial positions, hence, leading us to posit both voiced and voiceless obstruents in the underlying system of consonants. However, since exceptionally the voiceless bilabial [p] and the voiceless retroflex [t̡] do not occur in the contrastive medial positions, an exception is made for these subclasses of obstruents. For the latter, therefore, only the voiced [b] and [d], which occur in medial positions, are chosen to represent the contrastive segments. In line with these fact-based inferences, the revised inventory of Kabiye consonant phonemes is shown in Table 4.3. It comprises 22 consonants, which include all the voiced and voiceless obstruents inventoried in the contrastive medial positions after a morpheme. It shows obstruents in contrastive voiced and voiceless pairs in their subclasses, except those in the bilabial and retroflex classes that are defective, with only voiced phonemes.

Table 4.3 Revised Inventory of Kabiye Consonant Phonemes

	Bilabial	Labio-Dental	Alveolar	Retroflex	Palatal	Velar	Labial-Velar	Glottal	Archiphoneme
Stop	b		t d	ɖ		k g	kp gb		
Affricate					tʃ ɖʒ				
Fricative		f v	s z						
Nasal	m		n		ɲ				N
Liquid			l						
Approximant					j		w	h	

The obstruents shown in Table 4.3 allow us to also make two important inferences. Firstly, it is inferred that underlyingly voiced obstruents undergo a devoicing process in utterance-initial position, so that all the obstruents are realized as voiceless in this position. Many of the utterance-initial voiceless obstruents are accordingly derived by a devoicing process through a rule, which is formalized by (195).

(195) Rule 18 – Utterance-initial obstruent devoicing rule

$$C \text{ ----} > [-vd] / \#\# \text{ ---}$$

Secondly, it is inferred that Kabiye obstruents might be losing underlying voiced and voiceless contrast. It is argued that this contrast, which can be observed in surface obstruents only in medial positions, is still fully seen in obstruents of the alveolar subclass only; in contrast, it is already lost for obstruents in the bilabial and retroflex classes. For the remaining majority of the obstruents, this contrast is no longer obvious like in the alveolar obstruents, but the contrast is still kept idiosyncratically in medial positions and can be determined.

Opinions concerning the existence of underlying voiced and voiceless obstruents in Kabiye have varied. Some studies posited contrasting voiced and voiceless segments for all the occurring obstruents (Paaluki 1995), at times making exception in a subclass of obstruents (only the voiced /d/ is a phoneme in the retroflex class in CLNK & SIL-Togo 1998). Others followed the general cross-linguistic pattern and posited mainly voiceless obstruents as the contrastive segments, though with some exceptions too (the exceptions are /t d/ and /s z/ in Lébikaza 1999 and Roberts 2002, but /s z/, /b/, and /d/

instead, in Delord 1976). For most of the segments, Lébikaza (1999), for instance, initially based his argument on the case of obstruents such as [k ɡ] and [k̠ ɡ̠] for which only the voiceless allophones occur intervocalically in the root to posit the voiceless segments as phonemes. He then used this case as a basis for also positing contrastive voiceless allophones in the case of the other obstruents where he often deemed the choice not obvious otherwise. This applied especially to the bilabial and the retroflex allophones, which he determined to be in complementary distribution that could be equally derived from each other. In the analysis of Lébikaza, therefore, all the voiced obstruents, except the minimally contrasting alveolar ones, are derived by rules.

Neither view, however, has yielded conclusive results. In the case where all pairs of voiced and voiceless obstruents are posited as contrastive segments (Paaluki 1995), it is argued that these studies do not take into consideration the peculiar case of the bilabial obstruents on the one hand and the retroflex ones on the other, in complementary distribution allophonic relationship. CLNK & SIL-Togo 1998 has made an exception for the retroflex subclass of obstruents, positing only the voiced allophone underlyingly, yet ignoring the same behavior in the bilabial obstruents. The studies that have adopted the second view, which posits mostly contrastive voiceless segments with only some exceptions, arguing for a conditioning factor word-medially (for instance, a voicing assimilation of some obstruents between vowels and after a nasal), fail to explain the occurrence of obstruents as also voiced or voiceless in identical medial environments. Note that medial voicing rules fail to pinpoint the phonological

environments where the voicing should not apply. Therefore, medial voicing rules will only apply systematically to the bilabial and retroflex obstruents; for the remaining majority of the obstruents, medial voicing rules apply only randomly to some obstruents, as many obstruents fail to undergo voicing in medial positions. Furthermore, systems that posit mostly contrastive voiceless segments fail to explain the irrefutably contrastive voiced obstruents in the alveolar subclass, for which an exception will have to be made under medial voicing hypotheses.

From a theoretical point of view, a system that posits both underlying voiced and voiceless obstruents (as in Table 4.3) and derives utterance-initial voiceless obstruents by a single devoicing rule (as formulated above as Rule 18 in (195)), appears to be also more efficient and more economical in the case of Kabiye than systems that posit mostly voiceless underlying obstruents (with some exceptions) and derive voiced ones through a medial voicing assimilation rule. While only the utterance-initial devoicing rule is needed to apply systematically to all underlying voiced obstruents in Table 4.3 to derive their voiceless allophones utterance-initially, medial voicing assimilation rules applying to consonant systems with mostly underlying voiceless obstruents will also need an utterance-initial devoicing rule for the minimally contrastive voiced alveolar obstruents /d/ and /z/ in Lébikaza 1999 and Roberts 2002, or for /z/, /b/, and /d/ in Delord 1976. Consequently, in the case of Kabiye, medial voicing rules and systems with mostly underlying voiceless obstruents miss important generalizations.

Although this discussion has allowed us to determine the contrastive consonants of Kabiye, not all of the issues regarding the distribution of obstruents are yet resolved. Despite the contrastive occurrence of obstruents after morpheme boundaries as either voiceless or voiced, which has allowed to determine the contrastive consonants, the devoicing process that makes all obstruents voiceless at utterance-initial position makes it unclear which of the obstruents found in utterance-initial positions are underlyingly voiceless and which are underlyingly voiced. To determine which of the voiced or the voiceless phonemes occur in utterance-initial positions, we turn to a closer examination of the alternations of these obstruents in initial positions and after a morpheme boundary in an investigation of paradigms, in the next section. Paradigm investigation will also discredit an alternative interpretation that utterance-initial voiceless obstruents undergo a medial voicing assimilation after a morpheme boundary, which was discarded but not pursued in this phonological analysis.

4.3.5 Voiced and Voiceless Consonant Alternations after a Morpheme Boundary

Two tendencies have been observed in root-initial obstruents. First, after a morpheme boundary, root-initial voiced and voiceless obstruents often occur in similar, sometimes identical environments. Second, root-initial obstruents also have a tendency to alternate as voiceless at utterance-initial and voiced after a morpheme boundary. The latter behavior makes it almost impossible to predict which of the voiced or the voiceless obstruents occur underlyingly at the initial of roots.

The issue of word root initial obstruents alternation as voiced or voiceless after a morpheme boundary is discussed in the works of Lébikaza (1985, 1989, 1999), where it is correlated to an “interaction between segmental and suprasegmental features,” i.e., tone, syllable length, and stress. Lébikaza (1999: 135–142) argues that a root-initial obstruent is:

- (i) voiced after an L-toned short syllable,
- (ii) voiceless after an H-toned short syllable or after a long syllable, and
- (iii) voiceless³⁹ in the context (ii) when it is a polysyllabic root that has a voiceless onset final syllable.

Though this alternative interpretation did account for a substantial portion of the data, many exceptions are noted. To cite a few, the illustrations in (196) through (199) are in violation of (i); among these, the monosyllabic root of ‘warthog’, taken from Lébikaza’s illustrations, violates both (i) and (ii); those in (200) and (201) are in violation of (ii) and (iii).

- (196) [nó- dójè] ‘your warthog’
 your- warthog
- (197) [è- dī fé] ‘he did not massage’
 he- NEG massage
- (198) [è- dī- k̄pé] ‘he did not go home’ massage’
 he- NEG- go^home
- (199) [à- tʃèjà] ‘hooves’
 Pref- hooves

³⁹ Judging from his illustrations, the author appeared to have meant *voiced* instead of *voiceless*.

(200) [kí- 'dǎdíliù] 'long'
Pref- long

(201) [kí- bìniú] 'old'
Pref- old

The thesis adopted in the current study, however, departs greatly from the explanation given by Lébikaza. It is advocated that morphology plays an important role in how underlying obstruents surface in terms of voicing, obscuring hence their underlying specification. In addition to a systematic obstruents devoicing in utterance-initial environment, as determined in §4.3.4 (see Rule 18 shown as (195)), more patterns emerge in utterance-medial positions in the occurrence of root-initial voiced and voiceless obstruents, when extensive sets of paradigms are examined. These utterance-medial positions are defined as positions that include the initial of a word occurring after another word in an utterance when there is no intervening pause.

In utterance-medial position, there appears to be environments where root-initial obstruents are always voiced and environments where root-initial obstruents alternate as either voiced or voiceless. Examination of paradigms reveals that in some specific constructions, such as the Present Inaccomplished, the Accomplished, the Immediative, the Immediative Accomplished, the Past Inaccomplished, the Future, and the Future Anterior, where verb roots occur after a morpheme boundary, the initial obstruent of any given root is always voiced. However, in the majority of paradigms, the root-initial obstruents of verbs are either consistently voiced or consistently voiceless. These alternating constructions include the Expectative, the Adversative Accomplished, the

Adversative Inaccomplished, the Accomplished Anterior, the Jussive, the Jussive Inaccomplished, the Aorist (of Consecutive), etc. In constructions where the root is in utterance-initial position, such as the Imperative forms, root-initial obstruents always surface as voiceless.

Table 4.4 illustrates the paradigms of six representative verbs across some of the tense, mood, and aspect environments where the root-initial obstruents surface in utterance-medial position after a morpheme boundary as always voiced and as either voiced or voiceless in contrast to utterance-initial positions where they occur as always voiceless. Except for the forms in the Imperative and the Imperative Inaccomplished, all verb roots across the paradigms appear preceded by the subject prefix pronouns for ‘s/he’ or by the Expectative morpheme [tí-] or by the adjective formation prefix [kí-]. The morphemes that precede the roots have been specifically chosen to test the influence of tone and syllable length on the root-initial voiced and voiceless obstruents occurrence, as advocated in Lébikaza 1999.

As seen in the forms of the Imperative and the Imperative Inaccomplished in the second and third columns, respectively, where the verb roots appear in utterance-initial position, the root-initial obstruents of the verbs are always voiceless, as one would expect. In contrast, in the fourth through the sixth columns, in the constructions of the Present Inaccomplished, the Accomplished, and the Immediative, the root-initial obstruent of all six verbs surface as voiced. However, in the seventh through the eleventh columns, which illustrate the Aorist (of Consecutive), the Accomplished

Anterior, the Expectative (of Inaccomplished), the Inaccomplished Anterior, and after the adjectival prefix /kÍ-/ , the root-initial obstruents of the forms alternate. Specifically, the forms of ‘awake’, ‘mix’, and ‘uproot’ occur with a root-initial voiceless obstruent whereas the forms of ‘fan’, ‘cut’, and ‘smash’ occur with a root-initial voiced obstruent. It is also seen that these root-initial obstruents surface consistently as described regardless of the tone or the syllable length of the morpheme that precedes the verb root.

Table 4.4 Verbs with Underlying Voiced or Voiceless Root-Initial Obstruents

Underlying Initial Obstruent	DEVOICING ENVIRONMENTS (Always voiceless root-initial obstruents)		VOICING-ENVIRONMENTS (Always voiced root-initial obstruents)			VOICING-NEUTRAL ENVIRONMENTS (Root-initial obstruents alternating as either voiced or voiceless)					Glosses
	Imperative	Imperative Inaccomplished	Present Inaccomplished	Accomplished	Immediative	Aorist (of Consecutive)	Accomplished Anterior	Expectative (of Inaccomplished)	Inaccomplished Anterior	After /kí-/ 'Adjr' (deverbal adjective)	
/f/	[fè]	[fèŋ]	[è-vèŋ]	[è-vèmá]	[é-dí-'vérn]	[é-fé]	[ì-femá]	[tíí-féŋ]	[ì-fèŋgàú]	[kí-femàú]	'awake'
/v/	[fètí]	[fètíù]	[è-vétíù]	[è-vetàá]	[é-dí-'vétú]	[é-vètí]	[ì-vetàá]	[tíí-vétíù]	[ì-vetàú]	[kí-vetàú]	'fan'
/s/	[sídí]	[sídíù]	[è-zídiù]	[è-zidáà]	[é-dí-'zídú]	[é-sídí]	[ì-sidáà]	[tíí-sídíù]	[ì-sidàù]	[kí-'sídàù]	'mix'
/z/	[sétí]	[sétíù]	[è-zétíù]	[è-zetàá]	[é-dí-'zétú]	[é-zétí]	[ì-zetàà]	[tíí-zétíù]	[ì-zetàù]	[kí-'zetàù]	'cut'
/kp/	[kpézi]	[kpéziù]	[è-gbéziù]	[è-gbèzáà]	[é-dí-'gbézú]	[é-kpézi]	[ì-kpèzáà]	[tíí-kpéziù]	[ì-kpèzáù]	[kí-kpèzáù]	'uproot'
/gb/	[kpátí]	[kpátíù]	[è-gbátíù]	[è-gbátàà]	[é-dí-'gbátú]	[é-gbátí]	[ì-gbátàà]	[tíí-gbátíù]	[ì-gbátàù]	[kí-gbátàù]	'smash'

The data in Table 4.4 suggest that there are three types of environments relevant to obstruent voicing: devoicing environments, which are utterance-initial positions, as earlier defined, voicing-environments, which affect root-initial obstruents, and voicing-neutral environments, with no voicing effect on the root-initial obstruent. Though one might attempt to posit an initial devoicing rule to account for the root-initial voiceless obstruents in the second and third columns, and also a medial voicing rule to account for the ones in the fourth through the sixth columns, a medial voicing rule cannot account for the paradigms illustrated by the seventh through the eleventh columns. Rather, it is determined that the voicing of the root-initial obstruents after a morpheme boundary in some constructions is a property of these particular constructions. For instance, the predictable voicing of the root-initial obstruents in the paradigms of the Present Inaccomplished, the Accomplished, and the Immediative can be linked to these specific Tense Aspect Mood (TAM) constructions. It is argued that these constructions in Kabiye carry a floating voicing morpheme (the feature [+voice]), which accounts for the voicing observed in all the root-initial obstruents in these environments. In contrast, the lack of a floating voicing feature in the TAM constructions, such as the Aorist (of Consecutive), the Accomplished Anterior, the Expectative (of Inaccomplished), the Inaccomplished Anterior, and the formation of deverbal adjectives, allow the root-initial obstruents to surface with their inherent underlying voicing specification, which is seen as either voiced (as in the forms for ‘fan’, ‘smash’ and ‘cut’) or voiceless (as in ‘awake’, ‘uproot’, and ‘mix’). Other voicing-neutral constructions include the Jussive

and various negation constructions (viz. the forms of the Prohibitive or negation of the Imperative [tàà-fé] ‘don’t awake!’, [tàà-vétì] ‘don’t fan!’, [tàà-sìdí] ‘don’t mix!’, [tàà-zètí] ‘don’t cut!’, [tàà-kpèzí] ‘don’t uproot!’, and [tàà-gbátì] ‘don’t mash!’, or the negation forms of the Accomplished [è-dì-fé] ‘he did not awake’, [è-dì-vétì] ‘he did not fan’, [è-dì-sìdí] ‘he did not mix’, [è-dì-zètí] ‘he did not cut’, [è-dì-kpèzí] ‘he did not uproot’, and [è-dì-gbátì] ‘he did not mash’). The utterance-initial devoicing process (Rule 18, shown in (195) in §4.3.4), on the other hand, accounts for the root-initial voiceless obstruents in the forms of the Imperative and the Imperative Inaccomplished, which favor the occurrence of verb roots in utterance-initial position in language use.

The initial obstruents of noun roots exhibit the same behavior as verb root-initial obstruents. Nouns uttered in isolation (as in a wordlist) appear with a voiceless initial obstruent. In many environments, where nouns are preceded by another morpheme, they consistently appear with a voiced root-initial obstruent. These environments mainly include possessive constructions, where a noun can be preceded by a pronoun or by another noun. When nouns are preceded by some other morphemes, however, the root-initial obstruents alternate as either voiced or voiceless, as is the case of the pronoun [á-] ‘who’. We examine some of these environments in Table 4.5, specifically the constructions where noun roots occur after the L-toned pronouns /bÀ-/ ‘their’ and /kì-/ ‘its’, the H-toned pronoun /nÁ-/ ‘your (Sg)’, the L-toned noun [nèzè] ‘grandmother’, the H-toned noun [kólú] ‘blacksmith’, and the pronoun [á-] ‘who’.

Table 4.5 Nouns with Underlying Voiced or Voiceless Root-Initial Obstruents

Underlying root-initial obstruent	DEVOICING ENVIRONMENTS (Always voiceless root-initial obstruents)	VOICING-ENVIRONMENTS (Always voiced root-initial obstruents)						VOICING-NEUTRAL ENVIRONMENT (Voiced or voiceless Root-initial obstruents)	Glosses
	Noun (N) in wordlist forms	N preceded by /bÀ-/ 'Their'	N preceded by /kì-/ 'Its'	N preceded by /ɲÁ-/ 'Your (Sg)'	N preceded by H-tone noun 'N's N'	N preceded by L-toned noun 'N's N'	N preceded by /á-/ 'Who's'		
/f/	[fénú]	[pè-vènú]	[kì-vènú]	[ɲé-vènú]	[kólú 'vènú]	[nèzè vènú]	[á-fénú]	'spy'	
/v/	[fɔ̀lɔ̀tɔ̀]	[pò-vɔ̀lɔ̀tɔ̀]	[kì-vɔ̀lɔ̀tɔ̀]	[ɲó-vɔ̀lɔ̀tɔ̀]	[kólú vɔ̀lɔ̀tɔ̀]	[nèzè vɔ̀lɔ̀tɔ̀]	[á-vɔ̀lɔ̀tɔ̀]	'fiber bag'	
/v/	[fétá]	[pè-vètá]	[kì-vètá]	[ɲé-vètá]	[kólú 'vétá]	[nèzè vètá]	[á-vètá]	'toads'	
/kp/	[kpèlàá]	[pè-ḡbèlàá]	[kì-ḡbèlàá]	[ɲé-ḡbèlàá]	[kólú ḡbèlàá]	[nèzè ḡbèlàá]	[á-kpèlàá]	'chair'	
/ḡb/	[kpàànzùú]	[pà-ḡbàànzùú]	[kì-ḡbàànzùú]	[ɲá-ḡbàànzùú]	[kólú ḡbàànzùú]	[nèzè ḡbàànzùú]	[á-ḡbàànzùú]	'pepper'	
/tʃ/	[tʃàà]	[pà-ɕʒàà]	[kì-ɕʒàà]	[ɲá-ɕʒàà]	[kólú ɕʒàà]	[nèzè ɕʒàà]	[á-tʃàà]	'father'	
/ɕʒ/	[tʃètím]	[pè-ɕʒètím]	[kì-ɕʒètím]	[ɲé-'ɕʒètím]	[kólú 'ɕʒètím]	[nèzè ɕʒètím]	[á-'ɕʒètím]	'lie'	
/t/	[tíú]	[pà-díú]	[kì-díú]	[ɲá-díú]	[kólú 'díú]	[nèzè díú]	[á-tíú]	'tree'	
/d/	[túlútù]	[pù-dùlútù]	[kì-dùlútù]	[ɲú-dùlútù]	[kólú 'dùlútù]	[nèzè dùlútù]	[á-dùlútù]	'stupidity'	

As seen in Table 4.5, the nouns occur with an initial voiceless obstruent in a the second column (wordlist), whereas in all the possession constructions (columns three through seven) they occur with an initial voiced obstruent, regardless of the tone of the preceding morphemes. However, following the question formation pronouns [á-] ‘who’, the initial obstruent of some of the nouns occurs as voiceless and the initial obstruent of other nouns occurs as voiced. It is also the case of the prefix [a-] found on nouns such as [à-ɕ̀èjá] ‘countries’, [à-t̪̀èjà] ‘hooves’, [á-t̪̀éjá] ‘adultery’, [à-kòjà] ‘non-ripe fruit’, [à-t̪̀èjà] ‘mahogany fruit pod’, [à-gòòzà] ‘weeding’, [à-gúlùṅgú] ‘vulture’, [à-véjà] ‘jubilation’, [á-kájá] ‘(a species of snake)’. As also seen, whether preceded by an L-toned pronoun, an H-toned pronoun, an L-toned noun or an H-toned noun, the root-initial obstruents always surface as voiced in the voicing environments, but as either voiced or voiceless in the voicing-neutral environments. This finding leads us to conclude, unlike Lébikaza 1999, that neither tone nor syllable length has any significant bearing on the voicing with which the obstruents surface.

As in the previous case of verb roots, it is argued that the root-initial obstruents of the nouns in Table 4.5 are affected by the utterance-initial devoicing in the wordlist forms that appear in the second column. In utterance-medial position, they are affected by a voicing feature inherent to the possessive constructions (in the third through the seventh columns); in contrast, it is the lack of such a voicing feature in the question construction with ‘who’ (eighth column) and in the noun prefix [a-] (illustrated above) that allows the voicing alternation seen in the root-initial obstruents of these nouns. The

question construction with the prefix [á-] ‘who’ and the noun formation with the noun prefix [a-] are hence determined to be voicing-neutral environments, where the underlying root-initial obstruents surface as either voiced or voiceless.

Obstruents alternations after a morpheme boundary in the voicing-neutral contexts clearly support the analysis of the bilabial and retroflex obstruents posited in §4.3.4 as exceptional classes with only the voiced allophones as underlying segments. In Table 4.6 are illustrated the forms of four verb roots that begin with bilabial or retroflex obstruents across the same TAM environments as for the verb roots discussed earlier.

Table 4.6 Illustration of Verb Root-Initial Bilabial and Retroflex obstruents

Underlying Initial Obstruent	DEVOICING ENVIRONMENTS (Always voiceless root-initial obstruents)		VOICING-ENVIRONMENTS (Always voiced root-initial obstruents)			VOICING-NEUTRAL ENVIRONMENT (Root-initial obstruents alternating as either voiced or voiceless)					Glosses
	Imperative	Imperative Inaccomplished	Present Inaccomplished	Accomplished	Immediative	Aorist (of Consecutive)	Accomplished Anterior	Expectative (of Inaccomplished)	Inaccomplished Anterior	After /kÍ-/ ‘Adjr’ (deverbal adjective)	
/b/	[pì]	[pìh̃]	[è-bîh̃]	[è-bimá]	[é-dí-bírín]	[é-bí]	[ìi-bimá]	[tíi-bíh̃]	[ìi-bìh̃gàá]	[kí-bimàá]	‘burry’
/b/	[pédí]	[pédíù]	[è-bédíù]	[è-bèdáà]	[é-dí-bédú]	[é-bédí]	[ìi-bèdáà]	[tíi-bédíù]	[ìi-bèdáà]	[kí-bédáà]	‘sell’
/d/	[tėjí]	[tėjíù]	[è-řejíù]	[è-řejáà]	[é-dí-řejú]	[é-řejí]	[ìi-řejáà]	[tíi-řejíù]	[ìi-řejáà]	[kí-řejáà]	‘flatter’
/d/	[tòò]	[tòù]	[è-róù]	[è-řòwá]	[é-dí-řóú]	[é-řòò]	[ìi-řòwá]	[tíi-řóú]	[ìi-řòwàá]	[kí-řòwàá]	‘sleep’

In Table 4.6, it can be seen that root-initial obstruents occurring in utterance-initial position (third column) are voiceless, and they occur as voiced in utterance-medial position, both in the voicing-environments (fourth through the sixth columns) and in the voicing-neutral environments (seventh through tenth columns). For the verb roots ‘burry’ and ‘sell’, which begin with a bilabial obstruent, only the voiced [b] occurs after a morpheme boundary. For the roots of ‘praise’ and ‘sleep’ that begin with a retroflex obstruent, the voiced flap [ɾ] is seen between vowels, however, in slow or careful speech, the flap [ɾ] is commonly replaced with the voiced stop [d], in conformity to the allophonic relationship discussed in §4.3.2 (see Rule 12 in (114)). The voiceless allophones never appear in the alternating voicing-neutral contexts (cf. further verbal forms such as [è-dì-bázi] ‘he did not start’, [tàà-bázi] ‘do not start!’, [è-dì-dǎzi] ‘he did not rot’, [tàà-dǎzi] ‘do not get rotten!’, [kí-bìniú] ‘old’, [kí-'dǎlù] ‘long’, [kí-'dédéù] ‘saint’, and so forth).

The distribution of the bilabial and the retroflex obstruents at the initial of noun roots follows the same pattern as their distribution at verb root-initials in utterance-initial and utterance-medial. Examples of noun roots beginning with a bilabial or a retroflex obstruent are also illustrated in Table 4.7 across the environments illustrated earlier for noun roots.

Table 4.7 Illustration of Noun Root-Initial Bilabial and Retroflexes obstruents

Underlying root-initial obstruent	DEVOICING ENVIRONMENT (Always voiceless root-initial obstruents)	VOICING-ENVIRONMENT (Always voiced root-initial obstruents)						VOICING-NEUTRAL ENVIRONMENT (Voiced or voiceless Root-initial obstruents)	Glosses
	Noun (N) in wordlist forms	N preceded by /bÀ-/ 'Their'	N preceded by /kì-/ 'Its'	N preceded by /nÁ-/ 'Your (Sg)'	N preceded by H-tone noun 'N's N'	N preceded by L-toned noun 'N's N'	N preceded by /á-/ 'Who's'		
/b/	[pìjálàà]	[pà-bìjálàà]	[kì-bìjálàà]	[ná-bìjálàà]	[kólú bìjálàà]	[nèzè bìjálàà]	[á-bìjálàà]	'sons'	
/b/	[pé]	[pè-bé]	[kì-bé]	[né-bé]	[kólú bé]	[nèzè bé]	[á-bé]	'kernels'	
/d/	[t'éwù]	[pè-ɾ'éwù]	[kì-ɾ'éwù]	[né-ɾ'éwù]	[kólú ɾ'éwù]	[nèzè ɾ'éwù]	[á-ɾ'éwù]	'goodness'	
/d/	[t'álú]	[pà-ɾ'álú]	[kì-ɾ'álú]	[ná-'ɾ'álú]	[kólú 'ɾ'álú]	[nèzè ɾ'álú]	[á-'ɾ'álú]	'older brother'	

The occurrence of the root-initial bilabial and retroflex obstruents as always voiced after a morpheme boundary, in the voicing-neutral contexts, specifically, is a strong indication that only these voiced allophones are contrastive; a case which confirms the exceptional analysis posited for the obstruents in these classes in §4.3.4. Furthermore, for the retroflex obstruents, which manifest an allophonic relationship with liquids, the voiced obstruent is also chosen as the underlying phoneme, based on the general pattern of the underlying voiced obstruents to surface also as voiced obstruents in the voicing-neutral contexts and have a voiceless allophone in utterance-initial position.

The positing of voicing and voicing-neutral environments in Kabiye accounts remarkably well for the observed root-initial voiced and voiceless obstruents alternations in verbs and virtually all nouns. A small percentage of verb roots, though, show some degree of inconsistency across the voicing-neutral environments. The root-initial obstruents of these verbs appear to be voiced in some of the voicing-neutral environments, but voiceless in other voicing-neutral environments. Consequently, deciding which of the voiced or the voiceless obstruent occurs at the root-initial of the verbs in this small group is not as obvious. These verbs are illustrated by ‘massage’ and ‘die’ in Table 4.8.

Table 4.8 Illustration of Verbs with Unclear Underlying Voicing Specification of Initial Obstruent

Underlying Initial Obstruent	DEVOICING ENVIRONMENTS (Always voiceless root-initial obstruents)		VOICING-ENVIRONMENTS (Always voiced root-initial obstruents)			VOICING-NEUTRAL ENVIRONMENTS (Root-initial obstruents alternating as either voiced or voiceless)					Glosses
	Imperative	Imperative Inacc.	Present Inaccomplished	Accomplished	Immediative	Aorist (of Consecutive)	Accomplished Anterior	Expectative (of Inaccomplished)	Inaccomplished Anterior	After /kí-/ 'Adjr' (deverbal adjective)	
/f/ ~ /v/	[fê]	[fêkì]	[è-vékì]	[è-vèbá]	[é-dí- ¹ vébú]	[é-fé]	[ù-fèbá]	[tíí-vékí]	[ù-vèkàú]	[kí-fèbàú]	'massage'
/s/ ~ /z/	[sì]	[sìkì]	[è-zíkì]	[è-zìbá]	[é-dí- ¹ zìbú]	[é-sí]	[ù-sìbá]	[tíí-zíkí]	[ù-zìkàú]	[kí-sìbàú]	'die'

The verb roots in Table 4.8 tend to follow the same pattern as the great majority of verbs, with a voiceless root-initial obstruent in the devoicing environments (the Imperative and the Imperative Inaccomplished) and a voiced root-initial obstruent in the voicing environments (the Present Inaccomplished, the Accomplished, and the Immediative). They also tend to follow the pattern of most verbs in the voicing-neutral environments, where both verb roots occur with an initial voiceless obstruent in the TAM constructions of the Aorist, the Accomplished Anterior, and after the adjectival prefix, hence suggesting that they have an underlying voiceless root-initial obstruent. However, in the voicing-neutral TAM constructions of the Expectative and the Inaccomplished Anterior, where we would also expect these verbs to exhibit voiceless root-initial obstruents, their root-initial obstruents surface as voiced, suggesting that these verbs have underlying voiced root-initial obstruents, instead. The unexpected voicing of the root-initial obstruents of these verbs in only some of the voicing-neutral constructions makes it inappropriate to identify these roots with a voiceless initial obstruent though they clearly don't manifest themselves as roots with a voiced initial obstruent either. It can be stated though that the fact that such verb roots are not completely consistent in the voicing-neutral environments does not have any bearing on the inventory of the underlying voiced and voiceless obstruents. But it does signify that there still remains a percentage (though small) of outstanding verb roots, for which it cannot be decided if the underlying obstruent is voiced or voiceless.

This examination of voiced and voiceless alternations of root-initial obstruents has confirmed that Kabiye keeps voicing contrast of obstruents in medial positions and has further demonstrated that not all medial positions are equal: voicing contrasts are readily evidenced in medial positions in the simple root; they also occur after a morpheme boundary, but *only* in the voicing-neutral environments. It has revealed that in utterance-medial position after a morpheme boundary, there are voicing environments and voicing-neutral environments and the voicing specification with which the initial obstruent of a word root surfaces depends partly on the specific construction in which the root appears.

4.4 Conclusion of the consonantal analysis

This phonological reanalysis of Kabiye consonants has revised the phonetic inventory and the phonemic inventory. The only significant revision in the phonetic inventory has to do with the velar glide represented as [ɣ] in Lébikaza 1999, which is unattested in the Kabiye data by the new study. This segment, which first appeared in Delord 1976 as the fricative phoneme /ɣ/, was subsequently reanalyzed as a velar glide in Lébikaza 1985 and 1999, but not shown in Paaluki 1995 and later questioned in the works of Roberts (2002, 2003), is not validated in the current phonological analysis. The phonological analysis of the nasals has confirmed the phonemes /m/, /n/, and /ɲ/, which are determined to contrast pre-vocalically in initial and medial positions. But, much in support to Delord (1976), the inventory of contrastive nasals has also been revised to include a nasal archiphoneme /N/, which is determined to be the underlying

segment of the nasals that occur as noun prefixes and noun suffixes, and also in pre-consonantal positions in word roots. This nasal archiphoneme, surfaces always as a nasal that is homorganic to the following consonant and has been determined to carry the feature [+nasal] but is not specified for place of articulation. Therefore, in context, it shares the place of articulation of a following consonant.

However, the palatal nasal phoneme and the bilabial nasal phoneme can also surface in similar ways as the nasal archiphoneme when they end up in similar positions. There is a neutralization of the realizations of the nasal archiphoneme and the palatal nasal phoneme in word-initial and word-final positions, where the palatal nasal /ɲ/ represents an elliptic form of /ɲÁ/ ‘you’ as the 2nd person singular subject or object pronouns affixed to verb roots. This happens in word-final position by virtue of a phonological rule that imposes a velar realization to a non-bilabial nasal in this position. The bilabial nasal, on the other hand, is the only other phoneme that can also occur in pre-consonantal position in the word root, where it only assimilates to the place of articulation of a following voiced consonant.

The analysis of obstruents has revealed the existence of voicing environments and voicing-neutral environments, which, together with an utterance-initial devoicing environment, regulate the surfacing of the underlying voicing specifications of obstruents. In addition to a strong distributional restriction which bans obstruents in word-final position, these segments also undergo a devoicing process in utterance-initial position (defined as a position that coincides with the beginning of a sentence, the

beginning of a word occurring after a pause in a sentence, or the beginning of a word occurring in isolation, such as in a wordlist). Contrasts in obstruents are only seen in medial positions, with voiced and the voiceless obstruents having similar distributions and minimal pair contrasts found for the alveolar obstruents in the bare root. However, it has been determined that obstruents that occur at root-initials are also always subject to voicing after a morpheme boundary in some specific environments in the language. These environments carry with them a floating feature [+voice], therefore causing the initial obstruent of any given word root to be always realized as voiced. These environments include many Tense Aspect Mood (TAM) constructions, such as the Present Inaccomplished, the Accomplished, the Immediate, as well as nominal possessive constructions. Therefore, contrasts in root-initial obstruents are kept only in constructions that are voicing-neutral (in that they lack the floating voicing feature) and allow the root-initial obstruents' underlying voicing specification to surface. The latter environments include various other TAM constructions, among which the Aorist (of Consecutive), the Accomplished Anterior, the Jussive, the Expectative (of Inaccomplished), the Inaccomplished Anterior, deverbal adjective formation with /kì-/ , question constructions with /Á-/ 'who', etc.

The voiced and voiceless obstruents contrasts in medial positions, both in the simple root and after a morpheme boundary in the voicing-neutral constructions, allow us to conclusively posit contrastive voiced and voiceless segments in Kabiye. Therefore, all the voiced and voiceless obstruents that occur in these contrastive environments must be included in the phonemic consonant system. The inventory of all the obstruents

occurring in these specific contrastive environments yields a fuller range of obstruents, all of which constitute contrastive voiced and voiceless pairs, except the bilabial and retroflex voiceless obstruents. The peculiar behavior of the bilabial obstruents [p b] and the retroflex obstruents [ʈ ɖ] – for which the voiced allophones [b] and [ɖ] occur exclusively in medial position – results in a defect in the inventory of the contrastive obstruents in these two classes exceptionally, with only voiced phonemes.

CHAPTER 5

REVISION OF KABIYE VOCALIC PHONOLOGY

5.1 Revised Phonetic Inventory and Classification of Vowels

The phonetic inventory includes 18 basic vocoids, illustrated in Table 5.1.

Table 5.1 Illustration of Vocoids

[y]	[sýjé] ‘drum’	[e]	[tém] ‘to sustain’
[ɣ]	[sýjè] ‘hernia’	[ɛ]	[tém] ‘to finish’
[ø]	[tójè] ‘warthog’	[o]	[tóm] ‘sleep’
[œ]	[sœjùò] ‘to aspirate’	[ɔ]	[tóm] ‘salt’
[i]	[tím] ‘to cut down’	[ɯ]	[sìújè] ‘back’
[ɪ]	[tím] ‘gun powder’	[ɯ]	[mìùná] ‘nasal mucus’
[u]	[túm] ‘to clear (land)!’	[ɣ]	[sèýjè] ‘race’
[ʊ]	[tón] ‘bees’	[ʌ]	[téálím] ‘clear top of a drink’
[a]	[tám] ‘to bind’	[ɑ]	[háù] ‘dog’

While this phonetic inventory is the same as the one presented by Lébikaza (1999: 39), the classification of the vocoids is revised with new labels to reflect the newer understanding of the articulatory characteristics that allow a distinction of two sets of vocoids, as shown in Table 5.2. The classification of the vocoids follows the four criteria used in the description of vowels in most West African languages: tongue height, tongue backness, shape of the lips, and tongue root position. Along these criteria, we distinguish three heights in which the vocoids are paired, such that the first

of the pair (the vocoid to the left) is unrounded and the second of the pair (the vocoid to the right) is rounded. Note that the low vocoids lack rounded counterparts. The vocoids, classified according to the tongue root position criterion, come also in a second type of pairs; the nearly identical vocoids in this second pair type are differentiated by laryngeal features and tongue root position. Therefore, following this fourth criterion, two nearly symmetrical series or sets of vocoids emerge: Set 1 [i y e ø ɥ u ɣ o] and Set 2 [ɪ ʏ ε œ ʌ ɔ a].

Table 5.2 Revised Classification of Basic Vocoids in Two Sets

	Set 1: [-CONSTR]/[-RTR]		Set 2: [+CONSTR]/[+RTR]	
	FRONT	BACK	FRONT	BACK
HIGH	i y	ɥ ⁴⁰ u	ɪ ʏ	ʉ ɯ
MID	e ø	ɣ o	ε œ	ʌ ɔ
LOW			a	ɑ

The difference between Set 1 and Set 2 vowels has traditionally been discussed in terms of “tense” versus “lax” vowels (“voyelles lâches” / “voyelles tendues,” Delord 1976: 25) or in terms of difference in Advancement of Tongue Root⁴¹ (Kassan 1996, Lébikaza 1999, Roberts 2002), a criterion first defined by John M. Stewart in a study of the Akan vowel system (Stewart 1967: 185-203). Lébikaza states :

⁴⁰ This symbol is used in the current study to represent an unrounded high back vocoid, produced with a constricted pharynx and a retracted tongue root, as the appropriate symbol was not found in the IPA.

⁴¹ Crystal (1997) defines ATR - Advanced Tongue Root as “a movement which expands the front-back diameter of the pharynx.”

Selon la quatrième dimension [...] apparaissent d'un côté les voyelles [+ATR] [i, ü, e, o, u, o] réalisées grâce à la protraction de la racine de la langue ([ATR] en Anglais advanced tongue root = racine avancée de la langue), et de l'autre les voyelles [-ATR] [ɪ, ʏ, ε, ʊ, ɔ, a] articulées sans qu'il y ait un mouvement de la racine de la langue vers l'avant (Lébiakaza 1999: 40)⁴².

In recent research, however, it has been further argued that the two vowel sets of Kabiye differ not only in terms of their resonance features but also in terms of their articulatory postures (Edmondson & Esling 2006, Edmondson & Padayodi *et al.* 2007, and Padayodi 2008). Specifically, the new research has shown that the articulatory movement involved in the production of the traditional [-ATR] vowels is a retraction of the tongue root, instead, as had been previously predicted by Esling (Esling 1996: 81 and Esling 2005). Edmondson & Padayodi *et al.* 2007 write:

Laryngoscopic observations reveal a series of contrasting images for Set 1 [-constr] and Set 2 [+constr] vowels [i e u o] and [ɪ ɛ ʊ ɔ ɐ]. [...] As in the Yi and Akan contrastive series, Kabiye constricted vowels are systematically narrowed forwards and upwards across the aryepiglottic sphincter, tongue-retracted, and larynx-raised. In all of these cases, the [-constr] token corresponds to what has been called [+ATR], and the [+constr] token corresponds to what has been called [-ATR] (2007: 2067ff.).

Coincidentally, in his argumentation, Lébiakaza had also written:

⁴² “Following the fourth dimension [or criterion] appear on the one hand the [+ATR] vowels [i, ü, e, o, u, o] realized through the protraction of the tongue root ([ATR] in English advanced tongue root) and on the other the [-ATR] vowels [ɪ, ʏ, ε, ʊ, ɔ, a] articulated without a movement of the tongue root toward the front.” Note: ü = y, ɪ = i

John M. Stewart [...] a démontré que la différence entre les deux séries de voyelles résulte de la position de la racine de la langue (Stewart 1967 : 200 et suite). Comme dans le fanti étudié par John M. Stewart (1967), nous constatons que les voyelles [-ATR] du kabiye sont plus arrière[s] que les voyelles [+ATR] (Lébiakaza 1999: 40)⁴³.

It is important to notice that this statement by Lébiakaza is consistent with the “[-ATR] vowels” being produced with a “retracted” tongue root as found by the new research and not with an “advanced” tongue root.

The work of Edmondson and Esling (2006) pinpoints the articulatory difference between set 1 and set 2 vowels in their categorization of the valves of the throat in the production of both sets of vowels by means of laryngoscopic observation. Three of the valves of the larynx are seen in Figure 5.1 from Esling & Harris 2005 (as reproduced in Edmondson & Esling 2006a: 163). Of particular interest to this study is Valve 3 which Edmondson and Esling show to be an integral part of the production of [+RTR] (or [-ATR]) vowels in Kabiye. According to Edmondson and Esling, Valve 3 involves the “Sphincteric compression of the arytenoids and aryepiglottic folds forwards and upwards by means of the thyroarytenoid muscle complex” (2006a: 159). The arytenoid cartilages and aryepiglottic folds may be seen in the top half of Figure 5.1.

⁴³ “John M. Stewart [...] has shown that the difference between the two sets of vowels results from the position of the tongue root (Stewart 1967: 200 and following). As in the Fanti studied by John M. Stewart (1967), we notice that the [-ATR] vowels of Kabiye are further back than the [+ATR] vowels.”

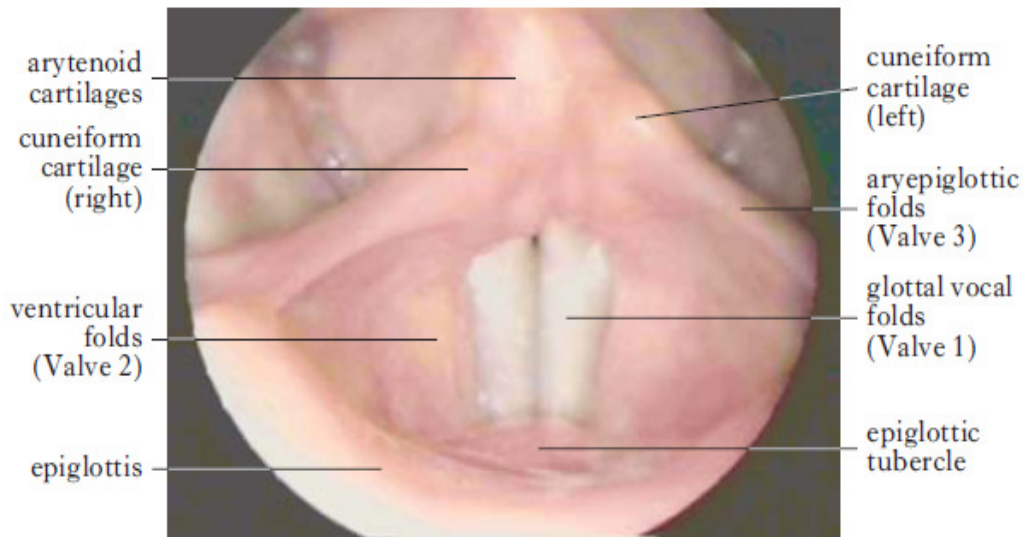
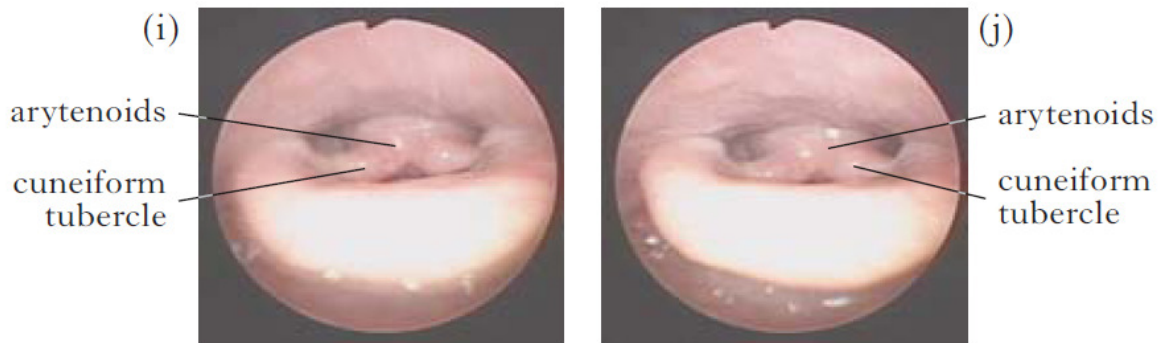

Figure 5.1 Three valves of the larynx (Esling & Harris 2005 as reproduced in Edmondson and Esling 2006a: 163)

In comparing the “Kabiye vowels with non-constricted and constricted laryngeal register,” Edmondson and Esling (2006a: 180-181) point out that “in each case, Set 2 vowels involve Valve 3, 4, and 5 (raised larynx), which are not active in Set 1, the non-constricted register.”

The classification of the low vowels [ɑ] and [a] as both belonging to Set 2 and having no counterparts in Set 1, as supported by some of the earlier studies, is further borne out by the work of Edmondson and Esling (2006). Figure 5.2i and Figure 5.2j from Edmondson & Esling 2006a “show the difference between [ɑ] in the context of non-constricted harmony and [a] in the context of constricted harmony” (p. 181).



/hólá/ [xólá] ‘nerves’ vs. /mílá/ [mílá] ‘sorghum’

Figure 5.2 Kabiye laryngeal postures representing the temporal mid-point in the final vowel [a] of words in (i) non-constricted (Set 1) and (j) constricted (Set 2) contexts.

Describing the phonation of [a] in both harmony contexts, Edmondson and Esling further state:

The vowel /a/ is noteworthy in the sense that it demonstrates constriction in both non-constricted and Set 2 registers, but Valve 3 and Valve 4 constriction appear to be greater in the constricted context. [...] Moreover, a vowel with constricted quality formed in the laryngeal vocal tract, such as [a], is inherently constricted (Valve 3) and does not allow a non-constricted form (unless the oral settings are significantly changed...) (Edmondson and Esling 2006: 181).

The new research has, therefore, evidenced that a major component in the articulation of Set 2 vowels is a “tongue-retracted” as opposed to the traditional conception of an “Advanced Tongue Root,” in which case it is more appropriate to talk of a feature [RTR] (Tongue Root Retraction) in the case of Kabiye and not [ATR] (Tongue Root Advancement), as it was previously suggested in a number of works on this language.

In order to reflect the insights from the new research into Kabiye description, the current study proposes to revise the differentiation between the two sets of vowels in terms of pharynx constriction and Retraction of Tongue Root ([RTR]). Accordingly, the traditional [+ATR] vowels (which lack constriction and retraction of tongue root) corresponding to Set 1 [i y e ø ɥ u ɣ o] are now identified as [-CONSTR] or [-RTR] vowels and the traditional [-ATR] vowels of Set 2 [ɪ ʏ ε œ ʊ ʌ ɔ ɑ a], articulated with pharynx constriction and tongue root retraction, are now referred to as [+CONSTR] or [+RTR] vowels. Hence, the two sets of vowels constitute contrasting [-CONSTR]/[-RTR] and [+CONSTR]/[+RTR] pairs as [i ɪ, y ʏ, e ε, ø œ, ɥ ʊ, u ʊ, ɣ ʌ, o ɔ], with the [+CONSTR]/[+RTR] low vowels [ɑ ɒ] from Set 2 not partaking in this contrast.

It is recalled that from a phonological perspective, the laryngeal constriction that distinguishes set 1 vowels from set 2 vowels is also known to impose a strong constraint on the combination of both sets of vowels in the phonological word. This constraint, which was first described in Akan and referred to as Vowel Harmony by Stewart (1967), allows only the vowels from one set (either Set 1 or Set 2) to occur together in the word. It has been determined in Kabiye, though, that the vowel /a/, which is from the [+CONSTR]/[+RTR] set, has a special status that allows it to combine quite freely with the vowels of either set, as seen in words such as [pùdòdìjé] ‘mercy’ (but not *[pùdòdìjé], *[pùdòdìjé], *[pùdòdìjé]) or [ɛ̀dòmìjé] ‘lip’ (but not *[ɛ̀dòmìjé] or *[ɛ̀dòmìjé]). This exception could also be seen as a supporting fact that Kabiye does not have an underlying [-CONSTR]/[-RTR] counterpart low vowels.

Another supporting evidence that the low vowels lack [-CONSTR]/[-RTR] counterparts is also seen in harmony contexts. It is known that the laryngeal harmony is controlled (or triggered) by the first vowel (the leftmost vowel) of the root: when the first vowel of the root is from the [-CONSTR]/[-RTR] set of vowels (Set 1), any co-occurring vowel is also from Set 1, and when the first vowel of the root is from the [+CONSTR]/[+RTR] set of vowels (Set 2), then any co-occurring vowel is also from Set 2. With the low vowels [a] and [ɑ], however, it is observed that this harmony control is not as strict. As Edmondson and Esling (2006: 181) state, “There is independent evidence that [ɑ] belongs to the constricted set. If a word begins with a non-constricted vowel, then the vowel [ɑ] is licensed to occur later in that word. But, if the leftmost vowel is [ɑ], then all following vowels must belong to set 2. That is to say, Kabiye possesses no lexical items with the structure C₁aC₂[i e u o], only C₁aC₂[ɪ ɛ ʊ ɔ ɑ].” In reality, this is only observed in verbs specifically, as illustrated by [kàndìjòù] ‘to stand astride’ and [pàzìù] ‘to start’. In nouns, a low vowel occurring as the leftmost vowel does not necessarily require the co-occurring vowels of the word to be of set 2 (cf. [hàkiú] ‘a plow’, [tʃááférè] ‘a turtle’, and [tʃàhkèré] ‘a sieve’). The only exceptions to this [CONSTR]/[RTR] Harmony are compounds, in which each constituent keeps its original vowel harmony as in [kójébìjé] ‘a tablet’ (from [kójè] ‘medication’ and [píjé] ‘kernel’) and [tʃòzínàù] ‘to take some with’ (from [tʃòzì] ‘to take some’ and [nà] ‘with’) and borrowings such as the following taken from Lébikaza 1999: [òtéèlì] ‘a hotel’ (from the French *hôtel*) and [fàɲsòvî] ‘Warsaw’ (from the French *Varsovie*, capital of

Poland). For an in-depth discussion on vowels harmonies in Kabiye, the reader is referred to existing descriptions, namely Kassan 1996 and Lébikaza 1999.

Of the 18 vocoids from the two sets listed in Table 5.2, a core 9 constituted by [i ɪ u ʊ e ε o ɔ a] occur in three quantities as short (V), long (VV), and extra long (VVV). Long vowels and extra long vowels show no noticeable difference in quality from their short counterparts. As their representations suggest, a long vowel is approximately twice as long as a short vowel, and an extra long vowel has a length that is (at least) three times the length of a short vowel. The vowels with the three quantities are illustrated by the forms in Table 5.3.

Table 5.3 Short Vocoids, Long Vocoids, and Extra Long Vocoids Illustrated

<i>Short Vocoids</i>		<i>Long Vocoids</i>		<i>Extra Long Vocoids</i>	
Vowel	Illustration	Vowel	Illustration	Vowel	Illustration
[i]	[tì] ‘cut down!’	[ii]	[tìì] ‘descend!’	[iii]	[kììì] ‘ideophone intensifying the idea or the feeling of a spin or dizziness’
[ɪ]	[sì] ‘die!’	[ɪɪ]	[sìì] ‘lay down!’	[ɪɪɪ]	[tʃììì] ‘ideophone intensifying the idea of redness’
[u]	[sù] ‘be quite!’	[uu]	[sùù] ‘wear!’	[uuu]	[sùùù] ‘ideophone intensifying the idea of length’
[ʊ]	[lò] ‘wrestle!’	[ʊʊ]	[lòù] ‘weave!’	[ʊʊʊ]	[lòùù] ‘ideophone intensifying the idea of length’
[a]	[sà] ‘praise!’	[aa]	[sàà] ‘drive!’	[aaa]	[sààà] ‘ideophone intensifying the idea of straightness’
[e]	[tè] ‘sustain!’	[ee]	[tèè] ‘sing!’	[eee]	[jètèèè] ‘ideophone intensifying the idea of open mouth’
[ɛ]	[tè] ‘finish!’	[ɛɛ]	[tèè] ‘leave!’	[ɛɛɛ]	[kɾèèè] ‘ideophone intensifying the idea of making rounds’
[o]	[lò] ‘cut at!’	[oo]	[lòò] ‘serve!’	[ooo]	[tòòò] ‘ideophone intensifying the idea of farness’
[ɔ]	[tò] ‘say!’	[ɔɔ]	[tòò] ‘eat!’	[ɔɔɔ]	[sòkòlòòò] ‘ideophone intensifying the idea of dirtiness’

In addition to the occurrence of vocoids in three quantities as short, long, and extra long, many of the vocoids can also occur as diphthongs. From all the possible combinations emerge three types of diphthongs, the first two of which were already discussed by Lébikaza (1999: 42–44).

The first type of diphthongs shift from the quality of an unrounded front vowel at the beginning of the production to that of an unrounded back vowel toward the end of the production, while keeping the same aperture in both parts of the diphthong. The arrows in Figure 5.3 indicate this diphthongization involving a backing of the tongue.

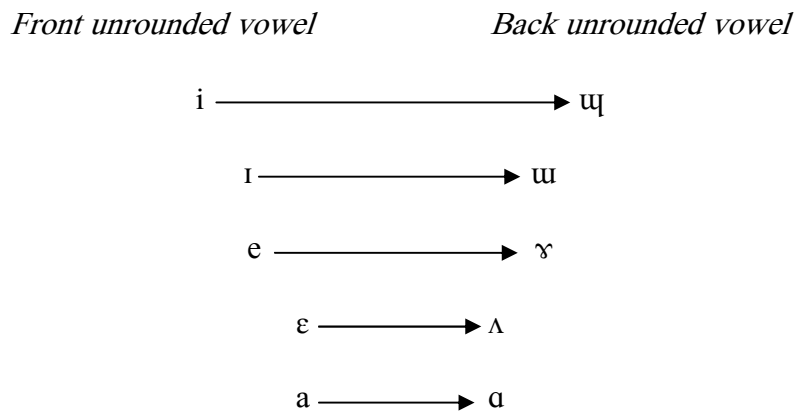

Figure 5.3 First type of diphthongs, constituted by an unrounded front vowel and an unrounded back vowel of the same aperture.

The first type of diphthongs is illustrated as follows:

- [iɯ] [sìù] ‘plant!’
- [ɪʊ] [sìù] ‘keep laying down!’
- [eɤ] [séʒ] ‘lift up!’
- [ɛʌ] [tʃèʌ] ‘keep advancing!’
- [aɑ] [tʃàà] ‘sit down!’

The second type of diphthongs, shown in Figure 5.4, shift from the quality of an unrounded front vowel or a rounded non-high back vowel at the beginning of the production to the quality of a rounded high back vowel at the end of the production. This diphthongization, which is characterized by a general upward and backward movement of the tongue, is also illustrated by the direction of the arrows.

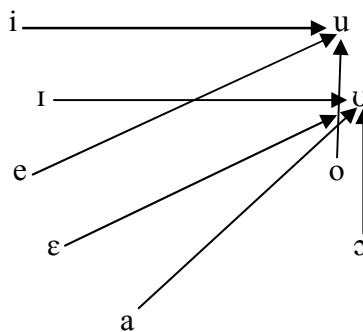

Figure 5.4 Second type diphthongs, gliding from an unrounded front vowel or a rounded non-high back vowel to a rounded high back vowel.

The second type of diphthongs is illustrated as follows:

[iu]	[líú] ‘to dip’	[ɛʊ]	[léú] ‘to wear (shoe, etc.)’
[ɪʊ]	[líú] ‘to get out’	[eʊ]	[séù] ‘to run’
[ou]	[lóú] ‘to serve (food)’	[ɔʊ]	[lòù] ‘to throw’
[aʊ]	[láú] ‘to immolate’		

The third type of diphthongs shifts from the quality of a rounded back vowel or an unrounded non-high front vowel at the beginning of the production to that of an unrounded high front vowel at the end of the production. Characteristically, therefore, this diphthongization shows a general upward and frontward tongue movement, as indicated by the arrows in Figure 5.5.

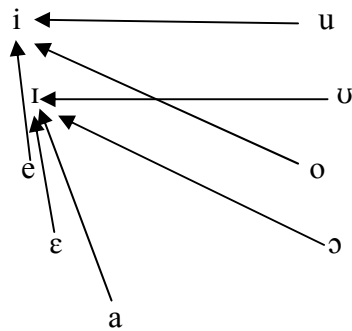

Figure 5.5 Third type of diphthongs gliding from a rounded back vowel or an unrounded non-high front vowel to an unrounded high front vowel.

An illustration of the third type of diphthongs is as follows:

- [ei] [ʔéi] ‘okay’
- [ɛi] [têi] ‘(male proper name)’
- [ai] [kɔ́páí] ‘catch him!’
- [oi] [kóí] ‘(interjection of disagreement)’
- [ɔi] [lòì] ‘ideophone (indicating the appearance of paste thrown against something)’
- [ɯi] [kúí] ‘stand up!’
- [ui] [lúí] ‘whip him!’

Some important articulatory characteristics differentiate the three types of diphthongs, all of which have to do with tongue movement during the production of the diphthongs. Only the backing of the tongue is involved in the articulation of the first type of diphthongs (Figure 5.3), unlike the other two types. The diphthongs in the second type (Figure 5.4) show either a simple backing of the tongue, a raising of the tongue, or simultaneous backing and raising of the tongue. Those in the third type (Figure 5.5) involve either a simple fronting of the tongue, a raising of the tongue, or simultaneous fronting and raising of the tongue. Lip rounding is another feature that

differentiates the articulation of the last two types of diphthongs from those in the first type: in the articulation of the second type of diphthongs, the shape of the lips shifts from spread to rounded, whereas in the articulation of the third type of diphthongs, the shape of the lips shift from rounded to spread. In the articulation of the first type of diphthongs, however, the spread shape of the lips remains constant. Therefore, the two vocoids in the first type of diphthongs have the same aperture. On the other hand, the diphthongs in the second and third types end always in a high vowel, independent of where they began. Combined in Figure 5.6 are shown all the diphthongization possibilities within the phonetic chart of the vocalic system.

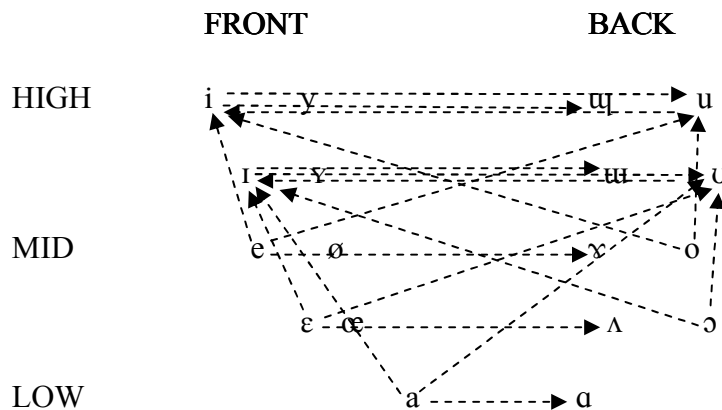

Figure 5.6 The Combined diphthongization possibilities of the vocalic system

A few remarks can also be made about the vowel diphthongization in general. The back unrounded vocoids [ɯ ʉ ɯ ʌ ɔ] in the first type of diphthongs, can only be found as second elements of diphthongs. Furthermore, it is noticeable in Figure 5.6 that most of the vocoids can be combined into diphthongs, but the front rounded vocoids [y ø œ], never enter into any type of diphthongization. Besides, importantly for all the

diphthongization possibilities, the vocoids in a diphthong are from the same set of vowels (either Set 1 or Set 2).

At the phonetic level thus, from single vocoids to long and extra long vocoids through three types of diphthongs, one might count a significantly large number of vocalic phones: up to 55 phones, as presented in the above inventory, depending on how the sounds are viewed. Independent of how one counts the vocoids, the next step in the phonological analysis remains the same, which is to determine which of the surface vocoids are contrastive.

5.2 Revised Phonological Analysis of Vowels

Determining the inventory of the phonemes that constitute the vocalic system begins with the identification of possible minimal pairs. Lébikaza (1999)⁴⁴ gives us a possible four-way opposition of the vowels.

5.2.1 Front Vowels versus Back Vowels

From the front vowels versus back vowels opposition, we find the following minimal pairs:

(202)	/i/	vs.	/u/
	[lì] ‘swallow!’		[lù] ‘forge!’
	[tì] ‘cut down!’		[tù] ‘clear (land)!’

⁴⁴ The analysis follows in the steps of Lébikaza (1999: 44–48) but the examples supplied are our own.

- (203) /i/ vs. /u/
 [tíṅ] ‘trees’ [tón] ‘bees’
 [sìì] ‘lay down!’ [sùù] ‘enter!’
- (204) /e/ vs. /o/
 [lè] ‘dry (in the sun)!’ [lò] ‘cut at!’
 [sé] ‘run!’ [só] ‘drums’
- (205) /ɛ/ vs. /ɔ/
 [tè] ‘finish!’ [tò] ‘say!’
 [tʃéwú] ‘to leave’ [tʃówú] ‘to grow many’
- (206) /a/ vs. /ɔ/
 [tà] ‘bind!’ [tò] ‘say!’
 [lábù] ‘to do’ [lóbù] ‘to thatch’

5.2.2 Front Vowels Opposed by Aperture

5.2.2.1 High Vowels Opposed to Non-High Vowels

- (207) /i/ vs. /e/
 [tì] ‘cut down!’ [tè] ‘sustain!’
 [lìbù] ‘to swallow’ [lébù] ‘to get lost’
- (208) /i/ vs. /ɛ/
 [tì] ‘estimate!’ [tè] ‘finish!’

5.2.2.2 Non-Low Vowels Opposed to Low Vowels

- (209) /e/ vs. /a/
 [lè] ‘dry (in the sun)!’ [là] ‘do!’
 [tè] ‘sustain!’ [tà] ‘bind!’
 [nèám] ‘polished stone’ [nám] ‘antelope’

- | | | | |
|-------|---------------------|-----|---------------------|
| (210) | /ɛ/ | vs. | /a/ |
| | [pɛ̀] ‘deprive!’ | | [pà] ‘cover!’ |
| | [tɛ̀m̩] ‘to finish’ | | [tám̩] ‘to bind’ |
| (211) | /i/ | vs. | /a/ |
| | [lì] ‘swallow!’ | | [là] ‘do!’ |
| | [tì] ‘cut down!’ | | [tà] ‘bind!’ |
| (212) | /i/ | vs. | /a/ |
| | [sím̩] ‘to know’ | | [sám̩] ‘to praise’ |
| | [ním̩] ‘wealth’ | | [nám̩] ‘to respect’ |

5.2.3 Back Vowels Opposed by Aperture

- | | | | |
|-------|-----------------------|-----|-----------------|
| (213) | /u/ | vs. | /o/ |
| | [lù] ‘forge!’ | | [lò] ‘cut at!’ |
| (214) | /ʊ/ | vs. | /ɔ/ |
| | [sùù] ‘enter!’ | | [sòò] ‘forget!’ |
| | [sútù] ‘Nereid fruit’ | | [sótù] ‘venom’ |

5.2.4 Vowels Opposed by Tongue Root Position ([+RTR] vs. [-RTR])

- | | | | |
|-------|------------------------|-----|---------------------------|
| (215) | /i/ | vs. | /ɪ/ |
| | [tì] ‘cut down!’ | | [tɪ] ‘estimate!’ |
| | [ním̩] ‘oil’ | | [ním̩] ‘to become convex’ |
| (216) | /u/ | vs. | /ʊ/ |
| | [tú] ‘an elephant’ | | [tʊ] ‘a bee’ |
| | [húwú] ‘to swell’ | | [hʊwʊ] ‘to soften’ |
| (217) | /e/ | vs. | /ɛ/ |
| | [pé] ‘kernels, grains’ | | [pɛ̀] ‘stones’ |
| | [tè] ‘sustain!’ | | [tɛ̀] ‘finish!’ |

(218)	/o/	vs.	/ɔ/
	[lò] ‘cut at!’		[lò] ‘thatch!’
	[tóm] ‘sleep’		[tóm] ‘salt’

These phonological oppositions allow us to make a number of initial deductions about the phonological status of the vocoids listed in the phonetic inventory at the beginning of this section. The front vs. back phonological oppositions of vowels allow us to make a distinction between the front phonemes /i ɪ e ε a/ and the back phonemes /o ɔ u ʊ/. The oppositions between high, mid and low vowels lead us to establish three classes of vowels: the class of high vowels /i ɪ u ʊ/, the class of mid vowels /e ε o ɔ/, and that of the low vowel /a/. This phonological distinction based on three levels of aperture holds only for the front vowels; for the back vowels, the opposition is only between the high vowels /u ʊ/ and mid vowels /o ɔ/, as the analysis shows no phonological opposition to the low vowels. The oppositions also show a phonological distinction between high vowels and mid vowels based on the feature [RTR], but not between low vowels because there is no such phonological opposition between the low vowels. We can thus deduce the following two phonological series: the [-RTR] vowels /i u e o/ and the [+RTR] vowels /ɪ ʊ ε ɔ a/.

The two series of contrastive vowels that have emerged from the phonological opposition by tongue root position constitute together the core nine vowel qualities that are manifested in three quantities as short, long, and extra long. While this opposition by tongue root position shows the short vowels to be contrastive, the status of the long

and the extra long vocoids still needs to be determined. It is discussed next, before the phonological analysis extends to the rest of the vocalic sounds.

5.2.5 Phonological Status of Long Vowels and Extra Long Vowels

The fundamental question that must be answered in determining the phonological status of the long vowels and the extra long vowels is simply stated as: Is vowel length contrastive in Kabiye? The first step in answering this question is to find minimal pairs that are differentiated not by vowel quality, but by vowel length. Only a few such words are found that contrast short, long, and extra long vowels. Further examination of the data shows that vowel length is contrastive but the extra long vowels are not attested in the phonological system.

The following minimal pairs show nine short vowels in opposition to long vowels.

(219) a. [kètíù] ‘to gather’

b. [kèètíù] ‘to circle’

(220) a. [k̀p̀è̀d̀f̀ù] ‘to spill’

b. [k̀p̀è̀è̀d̀f̀ù] ‘to pack’

(221) a. [kítíù] ‘to return’

b. [kìtíù] ‘to get nowhere’

(222) a. [sì] ‘die!’

b. [sìì] ‘lay down!’

(223) a. [m̀z̀í̀ù] ‘to suck’

b. [m̀z̀ù̀z̀í̀ù] ‘to make (sth. or someone) disappear’

(224) a. [sù] ‘be quite!’

b. [sùù] ‘wear!’

(225) a. [sà] ‘praise!’

b. [sàà] ‘drive!’

(226) a. [lò] ‘cut at!’

b. [lòò] ‘serve!’

(227) a. [tò] ‘say!’

b. [tòò] ‘eat!’

These examples clearly establish a phonological contrast between the short vowels and the long vowels as /e/ vs. /ee/ in (219), /ɛ/ vs. /εε/ in (220), /i/ vs. /ii/ in (221), /ɪ/ vs. /II/ in (222), /ʊ/ vs. /ʊʊ/ in (223), /u/ vs. /uu/ in (224), /a/ vs. /aa/ in (225), /o/ vs. /oo/ in (226), and /ɔ/ vs. /ɔɔ/ in (227). However, establishing a similar phonological contrast of these vowels with the extra long ones is not as straightforward.

As the data in Table 5.3 suggest, there appears to be a distinction between short, long vowels, and extra long vowels in the language. Fully understanding this relationship in morphologically rich contexts, however, becomes more complicated, as there appears to be phonological processes that manipulate vowel length: more specifically, in some contexts, underlying long vowels are shortened, thereby giving rise to surface-level homophony between forms with distinct underlying roots.

Considering the data in (228), the long vowels occurring in the Imperative forms in the first column (repeated from Table 5.3), appear to alternate with short vowels in the forms of the same roots in the second and third columns. The data in (229) illustrate

long vowels of the Imperative forms in the first column in alternation with short vowels in the second column, both of which also alternate with the extra long vowels occurring in the Infinitive forms shown in the third column. The same words therefore appear to have short vowels, long vowels, or extra long vowels depending on their morphological inflections.

(228)	[lòù] 'weave!'	[á lówá] 'who wove?'	[pà dì lù dá] 'they have not yet woven'
	[sàà] 'drive!'	[á sáwá] 'who drove?'	[pà dì sà dá] 'they have not yet driven'
	[tìì] 'descend!'	[á tóbá] 'who descended?'	[pè dì tìbì dá] 'they have not yet descended'
	[sìì] 'lay down!'	[á síwá] 'who laid down?'	[pà dì sì dá] 'they have not yet laid down'
	[lòù] 'serve!'	[á lówá] 'who served?'	[pà dì lò dá] 'they have not yet served'
	[tùù] 'crawl!'	[á túwá] 'who crawled?'	[pà dì tù dá] 'they have not yet crawled'
	[tòò] 'eat!'	[á tówáá] 'who eat?'	[pà dì tòò dá] 'they have not yet eaten'
	[tèè] 'sing!'	[á téwá] 'who sang?'	[pà dì tè dá] 'they have not yet sung'
(229)	[túú] 'diminish!'	[á tówáà] 'who diminished?'	[tùùù] 'to diminish'
	[mòù] 'disappear!'	[á múwáá] 'who disappeared'	[mòùù] 'to disappear'
	[nùù] 'carry on (your) lap!'	[á núwáá] 'who carried on lap'	[nùùù] 'to carry on the lap'
	[túú] 'swear!'	[á tówáá] 'who swore?'	[tùùù] 'to swear'

In contrast, there are verbal roots for which no such alternations between short, long, and extra long vowels exist. These appear in (230).

(230)	[lò]	[á lúbá]	[pà dì lùbì dá]
	‘wrestle!’	‘who wrestled?’	‘they have not yet wrestled’
	[sà]	[á sámá]	[pà dì sàm dá]
	‘praise!’	‘who praised?’	‘they have not yet praised’
	[tì]	[á tímá]	[pà dì tìm dá]
	‘cut down!’	‘who cut down?’	‘they have not yet cut down’
	[sì]	[á síbá]	[pà dì sìbì dá]
	‘die!’	‘who died?’	‘they have not yet died’
	[lò]	[á lómá]	[pà dì lòm dá]
	‘cut (at)!’	‘who cut (at)?’	‘they have not yet cut (at)’
	[tù]	[á túmá]	[pà- dì tùm dá]
	‘clear (land)!’	‘who cleared (land)?’	‘they have not yet cleared (land)’
	[tò]	[á tówá]	[pà dì tó dà]
	‘spit!’	‘who spat?’	‘they have not yet spat’
	[tè]	[á témá]	[pà dì tèm dá]
	‘sustain!’	‘who caught?’	‘they have not yet caught’

For the forms in (230), the consistent appearance of a short vowel in all contexts would lead us to conclude that the underlying form for the verbal root includes a short vowel. In the case of the alternating roots in (228) and (229), however, positing a short underlying vowel would prove problematic, as any rule that would lengthen such a vowel (e.g., in the imperative or infinitive forms) would have the unfortunate effect of also applying to the forms in (230), which would lead to unattested forms. Hence, the logical alternative would be to posit long vowels for the verbal roots in (228) and (229), along with phonological processes that shorten these underlying long vowels in specific

(morpho-)phonological contexts.

The vowel shortening rule that derives the short vowels in the second and third columns in (228) and also in the second column in (229), when the root is followed by another morpheme, from the underlying long vowels, which occur in the bare root forms in the first columns, is formulated as follows:

(231) Rule 19 – Vowel shortening rule (VS-rule)

$$\left/ \begin{array}{c} \text{V} \\ +\text{long} \end{array} \right/ \quad \text{-----} > \quad \left[\begin{array}{c} \text{V} \\ -\text{long} \end{array} \right] \left/ ______ \#Y \right/$$

(With Y representing a morpheme)

An application of this vowel shortening rule to a few sample roots derives the surface forms of nouns and verbs from roots with underlying long vowels in (232) and (233) and roots with underlying short vowels in (234) and (235).

(232) Underlying long vowel verb roots /sìr-/ ‘lay down’, /lùu-/ ‘weave’, and /tèè-/ ‘sing’

Paradigms	UR form	VS-rule	Surface form	Gloss
a. Infinitive	/sìr + Ú/	[sí-w-ú]	[síwú]	‘to lay down’
Accomplished	/sìr + á/	[sì-w-á]	[sìwá]	‘laid down’
Imperative	/sìr + ø/	N/A	[sì]	‘lay down!’
Consecutive	/sìr + ø/	N/A	[sî]	‘(then) laid down’
b. Infinitive	/lùu + Ú/	[lú-w-ú]	[lúwú]	‘to weave’
Accomplished	/lùu + á/	[lù-w-á]	[lùwá]	‘wove’
Imperative	/lùu + ø/	N/A	[lù]	‘weave!’
Consecutive	/lùu + ø/	N/A	[lú]	‘(then) wove’
c. Infinitive	/tèè + Ú/	[té-w-ú]	[téwú]	‘to sing’
Accomplished	/tèè + á/	[tè-w-á]	[tèwá]	‘sang’
Imperative	/tèè + ø/	N/A	[tèè]	‘sing!’
Consecutive	/tèè + ø/	N/A	[tèè]	‘(then) sang’

(233) Underlying long vowel noun roots /m̀d̀ɔ́j-/ ‘bone’, /líid-/ ‘money’, /k̀àaw-/ ‘rock’, and /ǹèej-/ ‘calf’

Paradigms	UR form	VS-rule	Surface form	Gloss
a. Singular	/m̀d̀ɔ́j + È/	[m̀d̀ɔ́j-è]	[m̀d̀ɔ́jè]	‘bone’
Plural	/m̀d̀ɔ́j + ø/	N/A	[m̀d̀ɔ́]	‘bones’
b. Singular	/líid + `jÉ /	[líid-ì-jé]	[líidjé]	‘money’
Plural	/líid + `É/	[líid-é]	[líídé]	‘monies’
c. Singular	/k̀àaw + Ú/	[k̀àaw-ú]	[k̀àawú]	‘rock’
Plural	/k̀àaw + `Ñ/	[k̀àá-ṅ]	[k̀àáṅ]	‘rocks’
d. Singular	/ǹèej + É/	[ǹèèj-é]	[ǹèèjé]	‘calf’
Plural	/ǹèej + á/	[ǹèèj-á]	[ǹèèjá]	‘calves’

(234) Underlying short vowel verb roots /s̀ìb-/ ‘die’ and /t̀èm-/ ‘sustain’

Paradigms	UR form	VS-rule	Surface form	Gloss
a. Infinitive	/s̀ìb + Ù/	N/A	[s̀ìb̀̀]	‘to die’
Accomplished	/s̀ìb + á/	N/A	[s̀ìbá]	‘died’
Imperative	/s̀ìb + ø/	N/A	[s̀ì]	‘die!’
Consecutive	/s̀ìb + ø/	N/A	[s̀ì]	‘then, died’
b. Infinitive	/t̀èm + Ù/	N/A	[t̀ém̀̀]	‘to sustain’
Accomplished	/t̀èm + á/	N/A	[t̀éma]	‘caught’
Imperative	/t̀èm + ø/	N/A	[t̀è]	‘sustain!’
Consecutive	/t̀èm + ø/	N/A	[t̀é]	‘(then) caught’

(235) Underlying short vowel noun roots /k̀ɔ́j-/ ‘medicine’, /k̀él-/ ‘tooth’, and /èj-/ ‘man’

Paradigms	UR form	VS-rule	Surface form	Gloss
a. Singular	/k̀ɔ́j + È/	N/A	[k̀ɔ́jè]	‘medicine’
Plural	/k̀ɔ́j + ø/	N/A	[k̀ɔ́]	‘medicines’
b. Singular	/kel + `d̀È/	N/A	[k̀ét̀̀è]	‘tooth’
Plural	/kel + `á/	N/A	[k̀èlá]	‘teeth’
c. Singular	/èj + Ú/	N/A	[èjú]	‘man’
Plural	/èj + àà/	N/A	[èjàà]	‘man’

Despite the effective application of the VS-rule, yielding the well-formed forms in (232) through (235) as corroborative evidence of long vowels contrasting with short vowels, a few exceptions are noted. These exceptions are of particular interest to the phonological analysis of vowels, as they show a correlation between the application of the VS-rule and the surface-level extra long vocoids in the infinitive forms in (229), indicating that these extra long vocoids are not attested in the underlying system.

Some monosyllabic roots keep their underlying long vowel before the infinitive suffix. Examples include roots such as /tɔɔ-/ in [tɔɔ-w-ù] ‘to eat’, /lɛɛ-/ in [lɛɛ-w-ù] ‘to snatch’, or /tèé-/ ‘sustain’ in [tèé-u]. Similar examples of verb roots with a long high back vowel have the morphological structure [tùú-ù] ‘to diminish’ (from /tùú-/), [mùú-ù] ‘to disappear’ (from /mùú-/), [nùú-ù] ‘to carry on the lap’ (from /nùú-/), and [tùú-ù] ‘to swear’ (from /dùú-/), (also transcribed with an inserted glide as [tùú-w-ù], [mùú-w-ù], [nùú-w-ù], and [tùú-w-ù], respectively). As attested by the internal structure of these forms, it is the failure of the VS-rule to shorten the underlying long rounded high back vowel before the homophonous rounded high back vowel of the infinitive suffix in such roots that gives rise phonetically to the surface-level extra long vocoids in (229). As a matter of fact, it is only in the infinitive forms of roots with a rounded high back vowel that the extra long vocoids are seen in non-ideophonic words. Hence, despite the seeming opposition of the extra long vocoids shown in the 3rd column in (229) with the contrastive long vowels in the 2nd column, the extra long vocoids in verbs are not attested in the underlying vowels system. The extra long vocoids in these forms are

underlyingly a long vowel and a short vowel, the first of which belongs to the verb root and the second to the suffix.

In regular (as opposed to ideophonic) word categories, a morphological boundary separates not only extra long vocoids, but some surface-level long vocoids, indicating that they are only attested at the surface level. Many phonetic long vocoids result from affixation and (morpho-)phonological processes, which give rise to consecutive homophonous underlying short vowels. Typically, a phonological process assimilates the aspectual suffix /-á/ of the Accomplished to the root vowel⁴⁵, resulting in surface level long vowels. Examples include [sòó] ‘bathed’ (from /só-/ + /-á/), [nàá] ‘saw’ (from /ná-/ + /-á/), [kpàá] ‘caught’ (from /kpá-/ + /-á/), or [sèé] ‘ran’ (from /sé-/ + /-á/), etc. However, a glide may be inserted between the root and the vocalic aspectual suffix, instead of an assimilation process, leading to the alternative forms [sòwá], [nàwá], [kpàwá] or [sèwá], respectively, for the same verbs.

Affixation alone does not account for all surface-level extra long vocoids, most of which occur in ideophones, which do not show an internal structure as the extra long vocoids in infinitive forms. The majority of surface-level extra long vocoids can be accounted for by a process of vowel lengthening in ideophones. As Lébikaza (1999)

⁴⁵ This vowel assimilation case is only noted about the root vowels /o/ and /ɔ/ by Lébikaza (1999: 73-74) and /ɔ/ by Kassan (1996: 29). But it is determined in the current research that it can be extended to all the short phonemes. Note, however, that the forms showing this assimilation case should not to be confused with similar forms of roots with underlying long vowels, such as [tḗḗ] ‘left’ (or [tḗwá], from /dḗḗ-/ + /-á/), [lìí] ‘exited’ (or [lìwá], from /lìi-/ + /-á/), or [dḗó] ‘slept’ (or [dḗwá], from /dḗo-/ + /-á/).

remarks, the extra long vowels occurring in ideophones can theoretically be elongated indefinitely. Therefore, examples of this type of words such as the ones which seemed to establish a contrast with short and long vocoids in Table 5.3, can also be transcribed as [kiiiii] ‘ideophone intensifying the idea of dizziness’, [kpèèèèè] ‘ideophone intensifying the idea of a making rounds’, [tòòòòòòòò] ‘ideophone intensifying the idea of farness’, [sààààààà] ‘ideophone intensifying the idea of straightness’, [lùùùùùùùù] ‘ideophone intensifying the idea of length’, and so forth. This characteristic vowel lengthening process, inherent to the extra long vocoids in ideophones, leads us to interpret these extra long vocoids as non-contrastive but only lengthened vowels.

It is concluded that Kabiye has contrastive long vowels, but its extra long vocoids are only attested at the surface level. Long vowels surface in some contexts, but phonological processes usually shorten underlying long vowels in specific (morpho-)phonological contexts. However, surface-level long vocoids might not always derive from corresponding underlying long vowels, as some surface-level long vocoids derive from consecutive short phonemes (of identical vowel quality), which are separated by a morphological boundary. Extra long vowels also arise in similar contexts, when the underlyingly consecutive vowels in the two different morphemes are constituted of a contrastive long vowel and a contrastive short vowel, both of the same quality. But, it is mainly a lengthening process, characteristic to ideophones, that accounts for most of the extra long vocoids.

5.2.6 Phonological Status of other Vocalic Elements and Diphthongs

No minimal opposition has been found for the vocoids [y ʏ ø œ ɥ ɯ ɤ ʌ ɑ] or any of the diphthongs, the phonological status of which is going to be determined through a study of the environments of their occurrence. These vocoids will be examined in three sets: the set [y ʏ ø œ] constituted by the vocalic elements that never enter diphthongization, the group of the diphthongs, and the set constituted by the vocalic elements [ɥ ɯ ɤ ʌ ɑ] that always occur as part of diphthong.

5.2.6.1 Phonological Status of [y ʏ ø œ]

Three main facts can be stated about the vocoids [y ʏ ø œ] that can help us determine their phonological status. Firstly, these vocoids occur in a very limited set of words in the language. Secondly, a close observation reveals that these sounds are found only in a very specific environment: they all occur before the palatal [j] in all of the examples (see [sýjé] ‘drum’, [sýjè] ‘hernia’, [tójè] ‘warthog’, [sécjùù] ‘to aspirate’). It could therefore be deduced that the vocoids [y ʏ ø œ] are palatalized allophones of some underlying vowels, which are affected by the following palatal.

The rule formalized in (236) derives all four allophones.

(236) Rule 20 – Palatalization rule

$$\begin{bmatrix} /u/ \\ /ʊ/ \\ /o/ \\ /ɔ/ \end{bmatrix} \text{ ----- } > \begin{bmatrix} [y] \\ [ʏ] \\ [ø] \\ [œ] \end{bmatrix} / \text{ — } [j]$$

As a matter of fact, language internal evidence appears to confirm this palatalization hypothesis: it has been observed that in some varieties of the language, such as those spoken in Somdina and Lassa, the words shown above have a parallel pronunciation as [sújé] ‘a drum’, [sújè] ‘hernia’, [tójè] ‘a warthog’, and [sójùù] ‘to aspirate’, respectively. Here it is seen that the palatalization rule is not used and the vowels remain unaltered. These alternative forms corroborate the direct correlation between the vocoids [y], [ɣ], [ø], [œ], and the back phonemes /u/, /ʊ/, /o/, /ɔ/, respectively, from which they are derived through a palatalization process. It has thus been determined that the vocoids [y ɣ ø œ] are not contrastive, which also seems to explain why these vocoids never participate in diphthongization.

5.2.6.2 Phonological Status of Diphthongs

The diphthongs of Kabiye identified at the phonetic level have not been determined to have a phonemic status. Instead, it has been shown that the diphthongs count each two vowels that can belong to different morphemes or two different syllables.

In the next set of alternating examples, the vocalic elements [ɥ ɯ ɤ ʌ ɑ] in the diphthongs [iɥ ɯɥ ɛɤ ɛʌ ɑɥ] of the first type are found as actual forms of the suffix marking various tenses and aspects of the verbs such as the Progressive and the Inaccomplished. Some of the second elements of the diphthongs also appear as noun class markers as attested by the last two forms in Table 5.4. It appears therefore, that these diphthongs are constituted of separate vocoids and are not underlyingly attested.

Table 5.4 Verbs with First Type of Diphthongs Versus Alternating Forms

[tìù] ‘rub!’	[tìkì] ‘keep rubbing!’	from /tìi-/ ‘rub’
[sìù] ‘keep laying!’	[sì] ‘lay down!’	from /sìi-/ ‘lay’
[tɛ̀λ] ‘leave’	[tɛ̀è] ‘leave!’	from /tɛ̀e-/ ‘leave’
[háù] ‘keep giving!’	[há] ‘give!’	from /há-/ ‘give’
[séɔ̀] ‘keep running!’	[sé] ‘run!’	from /sé-/ ‘run’
[léλ] ‘funeral’	[lésì] ‘funerals’	from /lé-/ ‘funeral’
[háù] ‘dog’	[hási] ‘dogs’	from /há-/ ‘dog’

Alternating verbal and nominal forms in the language attest that the high back vocoids ending the second type of diphthongs represent the Infinitive suffix morpheme in verbs (as in [líú] ‘to dip’ from /lii-/ ‘dip’ + /-u/ ‘INF’) and a singular class marker in nouns (as in [nǐú] ‘a crocodile’, from /ɲi-/ ‘crocodile’ + /-u/ ‘3SgT2’). In other forms of the same verbs and nouns, the first vocoids of the seeming diphthongs of the Infinitives and of the singular form of nouns always remains, but the high back vocoid which is second element of diphthongs, is no longer seen. Instead, it is replaced by various suffixes for the appropriate forms of the word as illustrated by the forms in Table 5.5 and Table 5.6. Consequently, it is determined that phonologically, the seeming diphthongs are not diphthongs in the true sense of the word, because underlyingly, they are sequences of two consecutive vowels.

Table 5.5 Second Type of Diphthongs Alternating with Other Vocoids in Verbs

Infinitive	Imperative	Accomplished	Root
[lí-ú] or [lí-w-ú]	[lì]	[lì-w-á]	/lìi-/ ‘dip’
[lí-ú] or [lí-w-ú]	[lì]	[lì-w-á]	/lìi-/ ‘get out’
[ló-ú] or [ló-w-ú]	[lò]	[lò-w-á]	/lòo-/ ‘serve’
[ná-ù] or [ná-w-ù]	[ná]	[ná-w-á]	/ná-/ ‘see’
[lé-ú] or [lé-w-ú]	[lè]	[lè-w-á]	/lèe-/ ‘wear’
[sé-ù] or [sé-w-ù]	[sé]	[sè-w-á]	/sé-/ ‘run’
[ɲó-ú] or [ɲó-w-ú]	[ɲò]	[ɲò-w-á]	/ɲòo-/ ‘drink’

Table 5.6 Second Type of Diphthongs Alternating with Other Vocoids in Nouns

Singular	Plural	Root
[líú] or [lí-w-ú]	[líŋ]	/li-/ ‘neck’
[níú] or [ní-w-ú]	[níŋ]	/ni-/ ‘crocodile’
[kṑóú] or [kṑó-w-ú]	[kṑóŋ]	/kṑo-/ ‘granary’
[láù] or [láwù]	[láŋ]	/lá-/ ‘forest’
[péú] or [péú]	[péŋ]	/pe-/ ‘pot’
[héù] or [héù]	[héŋ]	/hé-/ ‘sheep’
[póú] or [póú]	[póŋ]	/po-/ ‘hole’

It can also be argued with Delord (1976: 452) that the surface-level diphthongs in the Infinitives in Table 5.5 are truly separated by a /w/, which is unequivocally perceived before the aspectual marker of the Inaccomplished in verbs of these roots as ending in [-wa] (as shown in the examples). Unlike Delord, however, the current study advocates that the [w] is not part of the verb root; instead it is inserted by the suffixation process. In such verbal forms, therefore, the vowels of the seeming diphthongs may or may not be separated by a [w], depending on how one analyzes them. Either way, however, these surface-level diphthongs are always separated by a morphological boundary. In nominal forms (Table 5.6), it is not as easily demonstrable that they too include an intervening glide as in verbal forms, but the preference of the current analysis is to transcribe such nouns also with an intervening glide, in conformity to the general language pattern (see arguments in §1.3.4).

Similar to the first two types, the diphthongs [ei ei ai oi oi ui ui] of the third type can also be shown to be in fact split by a glide as in the alternating verbal forms in Table 5.7 (also see arguments in §1.3.4) or constituted of vocoids from different morphemes. It is argued that

the glide, which is part of the root, is followed by an epenthetic high vowel usually seen in the surface form of roots that end underlyingly in a non-nasal consonant, as in the imperative forms in Table 5.7. In the data in Table 5.8, on the other hand, it is seen that the unrounded high vowels, that are the second elements in the diphthongs, are sometimes identifiable with the class anaphoric object 3rd person pronoun for the Class-1 nouns (1SgT1) and the Class-4 nouns (4PlT2) (see Table 1.1, on page 38), suffixed to verbs.

Table 5.7 Words with Third Type of Diphthongs Versus Alternating Forms

[hèì] or [hèjì] ‘tell!’	[hèjàá] ‘was telling’
[kǎpéí] or [kǎpéjí] ‘sacrifice!’	[kǎpèjàà] ‘sacrificed’
[kàì] or [kàjì] ‘peel!’	[kàjàá] ‘peeled’
[kóí] or [kójí] ‘pick up! (from tree)’	[kòjàà] ‘pick up’
[sòì] or [sójì] ‘suck!’	[sòjàà] ‘sucked’
[kúí] or [kójí] ‘stand up!’	[kùjàà] ‘stood up’
[súì] or [sújì] ‘fill!’	[sújàà] ‘filled’

Table 5.8 Words with Third Type of Diphthongs as Object Suffixes

[kǎpá-í] ‘catch him!’
[lǎ-í] ‘throw it’
[kú-í] ‘kill him!’
[lú-í] ‘whip him!’

It appears from the analysis that the diphthongs are only attested at the phonetic level. Their constituent elements are either split by a glide or belong to separate morphemes, hence, to different phonemes, most of which as seen are the short and long phonemes already established. But the status of the vocoids [ɥ ɯ ɤ ʌ ɑ], appearing as second elements in the first type of diphthongs still needs to be determined. Due to the complexity of the status of these second elements, which are in fact all connected, they

will receive a separate treatment in the next sub-section. The rest of the phonological analysis thus focuses on determining the status of these remaining vocoids.

5.2.6.3 Phonological Status of the Vocalic Elements [ɯ ʊ ɤ ʌ ɑ]

This section examines the phonological status of the class constituted by the back unrounded vocoids [ɯ ʊ ɤ ʌ ɑ] in the phonetic chart, occurring as second elements in the first type of diphthongs. The question that needs to be answered about them is succinctly formulated as: What phoneme or phonemes do these vocalic elements represent?

It is necessary to begin by highlighting some observations about these vocoids, each of which shows the complexity of their status and will ultimately lead to answer this question. Most of these highlights were shown in Lébikaza 1999.

- a. It is first recalled from the discussion so far that the back unrounded vocoids [ɯ ʊ ɤ ʌ ɑ] can only appear as second elements of diphthongs (first type of diphthongs), but are separated from the vowel with which they constitute diphthongs by a morphological boundary (see Table 5.4 and discussion), leading to the deduction that they are only surface-level diphthongs, but not underlying so.
- b. The form of the elements [ɯ ʊ ɤ ʌ ɑ] varies according to the vowel that precedes them, i.e., the vowel with which they form the surface-level diphthong; hence, the environment in which these elements occur is predictable.

Thus: [ɯ] appears only after [i] to form the diphthong [iɯ]

[ʊ] appears only after [ɪ] to form the diphthong [ɪʊ]

[ɣ] appears only after [e] to form the diphthong [eɣ]

[ʌ] appears only after [ɛ] to form the diphthong [ɛʌ]

[ɑ] appears only after [a] to form the diphthong [aɑ]

This pattern suggests that the elements [ɥ ʊ ɣ ʌ ɑ] all are in complementary distribution after the front vowels [i ɪ e ɛ a], respectively.

- c. The distributional constraints that govern these back unrounded vocalic elements make difficult a phonological opposition between them and the vowels for which the phonological status has already been established. However, as pointed out by Lébikaza, the elements [ɥ ʊ ɣ ʌ ɑ] seem to establish a phonological opposition between the diphthongs [iɥ iʊ eɣ ɛʌ aɑ] of which they are the second elements and the long front vowels [ii ɪɪ ee ɛɛ aa], through a partial opposition in the second mora. The following examples support this point:

Table 5.9 Back Unrounded Vowels versus Front Unrounded Vowels
in the Second Mora of First Type of Diphthongs

[tìì] ‘descend!’	vs.	[tìù] ‘rub!’
[sìì] ‘lay down!’	vs.	[sìù] ‘keep laying down!’
[tèè] ‘sing!’	vs.	[tèɣ] ‘keep singing!’
[tèè] ‘leave!’	vs.	[tèʌ] ‘keep leaving’
[sàà] ‘drive!’	vs.	[sàɑ] ‘sculpture!’

- d. The vocalic elements [ɥ ʊ ɣ ʌ ɑ] can also be opposed to the high rounded back vowels [u ʊ] when the latter are second constituents of diphthongs, through the phonological oppositions to the second type of diphthongs in the second mora, as in the following examples.

Table 5.10 Back Unrounded Vowels versus Back Rounded High
Vowels in Second Mora of Diphthongs

[jíù] ‘keep licking’	vs.	[jîù] ‘to lick’
[níú] ‘press!’	vs.	[níó] ‘to be visible’
[téʒ] ‘sustain!’	vs.	[téú] ‘to sing’
[séá] ‘leave a rest!’	vs.	[séó] ‘to greet’
[háâ] ‘dog’	vs.	[háò] ‘to give’

e. At the same time, there seems to be an occurrence of the vocoids [ɥ ɯ ɤ ʌ ɑ] in free variation with the unrounded front vocoids [i ɪ e ε a] in the second mora of the long unrounded front vocoids [ii ɪɪ ee εε aa] in “the initial syllable” of word roots (Lébiakaza 1999: 50). Specifically, words including the diphthongs [iɥ ɪɯ eɤ εʌ aa] are pronounced by some speakers not with diphthongs but with the long unrounded front vowels [ii ɪɪ ee εε aa]. It is also observed that in the pronunciation of other speakers, the diphthongs (or the long vowels) in such words are replaced with long vocalic elements as [ɥɥ ɯɯ ɤɤ ʌʌ ɑɑ]. The same words might therefore be pronounced in three different ways in Kabiye, as illustrated in Table 5.11.

Table 5.11 Examples of Same Words Pronounced with Different Vowels

[-Back -Back]		[-Back + Back]		[+ Back + Back]	
[jìdíù]	or	[jìúdíù]	or	[jùúdíù]	‘to mistake’
[fìdíù]	or	[fìúdíù]	or	[fùúdíù]	‘to give care’
[pèèzíù]	or	[pèʒzíù]	or	[pʒʒzíù]	‘to soothe’
[pààlíù]	or	[pàðlíù]	or	[pàðlíù]	‘to grow up’
[mèèdíù]	or	[mèðdíù]	or	[mððdíù]	‘knead’

Theoretically, free variation suggests that the concerned sounds are allophones or variants of a same underlying phoneme. What that would mean in this specific case is that the elements [ɯ ʊ ʏ ʌ ɑ] are allophones of the front vowels phonemes /i ɪ e ε a/, respectively.

From the arguments in *a.* through *e.* about the distribution of the vocalic elements [ɯ ʊ ʏ ʌ ɑ], some partial conclusions can be inferred. The argument in *a.* indicates that these vocalic elements do not constitute underlying diphthongs with their preceding vowels. The complementary distribution of the elements [ɯ ʊ ʏ ʌ ɑ] shown in *b.* suggests that these elements all belong to a single phoneme. The oppositions in *c.* and *d.* suggest that the phoneme represented by the back unrounded vocoids [ɯ ʊ ʏ ʌ ɑ] is distinct from the long phonemes /ii ɪɪ ee εε aa/ and also distinct from the phonemes /u ʊ/ representing the infinitive marker in the second mora of the second type of diphthongs. However, it can be said that while the facts in *a.* through *d.* advance the understanding about the nature of the elements [ɯ ʊ ʏ ʌ ɑ], the free variation interpretation as in *e.* would be in flagrant contradiction with the phonological opposition established in *c.* between the elements [ɯ ʊ ʏ ʌ ɑ] and the front vowels [ii ɪɪ ee εε aa] through the opposition in the second mora of the diphthongs [iʊ ɪʊ eʏ εʌ aɑ]. This last point, which is argued to be only a diversion, will be ignored for now and will be more appropriately explained later in this analysis. The distribution criterion alone is not enough to give us the ultimate answer about the nature of the elements [ɯ ʊ ʏ ʌ ɑ]. The analysis, therefore, will be pursued further.

Considering what is already known about the vocalic system as a whole, and about the elements [ɯ ʊ ʏ ʌ ɑ] specifically, some hypotheses can be explored that might help account for the nature of the elements [ɯ ʊ ʏ ʌ ɑ]. All of these potential solutions, but the last one, were already debated by Lébikaza (1999: 49-56).

Hypothesis 1: Either /o/ or /ɔ/ underlies [ɯ ʊ ʏ ʌ ɑ].

The first hypothesis considers the possibility of the elements [ɯ ʊ ʏ ʌ ɑ] being surface manifestations of either of the phonemes /o/ or /ɔ/. First, it must be noticed that the back vowels /o/ and /ɔ/ are the remaining phonemes for which no apparent opposition with the vocalic the elements [ɯ ʊ ʏ ʌ ɑ] is seen. Indeed, /o/ and /ɔ/ are the back phonemes that never occur in diphthongs after the front vowels [i ɪ e ε a]. Therefore, it is possible that one of these back phonemes is the underlying phoneme of the back vocalic elements [ɯ ʊ ʏ ʌ ɑ], which appear precisely in that environment.

If /o/ were to be chosen as the underlying form, one would need a palatalization rule (Rule 1 of Lébikaza's solution 2, reproduced here as Rule 21) to derive the back unrounded vowels [ɯ ʊ ʏ ʌ ɑ].

(237) Rule 21 – Lébikaza's hypothetical Rule 1)

/o/	----->	}
	----->	
	----->	
	----->	
	----->	

[ɯ] / [i] ___

[ʊ] / [ɪ] ___

[ʏ] / [e] ___

[ʌ] / [ε] ___

[ɑ] / [a] ___

Likewise, if /ɔ/ were chosen, a similar palatalization, which is hypothetically formulated here as Rule 22, would be needed to derive the five elements. This second fold of the hypothesis was not shown by Lébikaza, but is included here for the sake of completeness.

(238) Rule 22 – Hypothetical Rule

$$/ɔ/ \text{ -----} > \left\{ \begin{array}{l} [\text{ɥ}] / [\text{i}] \text{ ---} \\ [\text{ɥ}] / [\text{ɪ}] \text{ ---} \\ [\text{ʎ}] / [\text{e}] \text{ ---} \\ [\text{ʎ}] / [\text{ɛ}] \text{ ---} \\ [\text{ɑ}] / [\text{a}] \text{ ---} \end{array} \right\}$$

The application of Rule 21 and Rule 22 would yield the following forms and their realizations⁴⁶:

(239) Derivations following Rule 21

/nio-U/	----->	[nìúù]	‘to moisten’
*/ɲio-U/	----->	[ɲìúù]	‘to press’
/seo-U/	----->	[sèʎù]	‘to lift’
/tʃao-U/	----->	[tʃàáù]	‘to sit’
*/lɛo-U/	----->	[lèʎù]	‘to snatch’
*/sɛo-U/	----->	[sèʎù]	‘to leave a rest’

⁴⁶ These examples were taken from Lébikaza 1999.

(240) Derivations following Rule 22

*/niɔ-U /	----->	[niúù]	‘to moisten’
/ɲiɔ-U /	----->	[ɲiúù]	‘to press’
*/seɔ-U /	----->	[sèʔù]	‘to lift’
/tʃaɔ-U/	----->	[tʃááù]	‘to sit’
/leɔ-U/	----->	[lèáù]	‘to snatch’
/seɔ-U/	----->	[sèáù]	‘to leave a rest’

Although this hypothesis is economical, a palatalization rule as a possible solution is not motivated in the first place nor is it plausible enough to explain the surface forms that are yielded in these examples. Furthermore, the choice of either of /o/ and /ɔ/ as the underlying phoneme for all the five elements [ɥ ʉ ʔ ʌ ɑ] is problematic because it introduces underlyingly a combination of set 1 vowels and set 2 vowels in the root, which is phonologically inappropriate in this language (as shown by the * preceding some of the forms in (239) and (240)). These points constitute stumbling blocks which suggest that either of /o/ and /ɔ/ as the possible underlying phoneme of which the elements [ɥ ʉ ʔ ʌ ɑ] would be combinatory variants must be rejected.

Hypothesis 2: [ɥ ʉ ʔ ʌ ɑ] are variants of both /o/ and /ɔ/.

Under this hypothesis (corresponding to Lébikaza’s solution 1), it is suggested that the [-RTR] vocalic elements [ɥ ʔ] and the [+RTR] vocalic elements [ʉ ʌ ɑ] would be matched with the phoneme of the same laryngeal specifications as themselves, which are /o/ and /ɔ/, respectively. But there are two major shortcomings for this proposed solution. First, the very limited distribution of these elements and the fact that they are in complementary distribution

give them the characteristics of allophones of a single phoneme. Second, Lébikaza argues that it would lead to two phonemes that cannot be phonologically opposed in the environments where [ɥ ʉ ʁ ʌ ɑ] appear. Therefore, it is concluded that this hypothesis is not satisfactory and another solution must be sought. This leads us to Lébikaza's third hypothesis.

Hypothesis 3: Either some abstract element or one of [ɥ], [ʉ], [ʁ], [ʌ], and [ɑ] underlies the vocoids [ɥ ʉ ʁ ʌ ɑ].

This solution postulated by Lébikaza consists in advocating that the phoneme that underlies the elements [ɥ ʉ ʁ ʌ ɑ] is distinct from the back rounded vocalic phonemes by the feature [-round] and from the front vocalic phonemes by the feature [+back] (which Lébikaza characterized by the French “[-avant]”). This underlying segment would thus be either an abstract reality defined as back unrounded vocalic phoneme, which would undergo Rule 23 below, or this underlying segment would be one of the five back unrounded vocalic elements – say, ‘ʁ’ for instance – which will undergo Rule 24 to derive the five surface vocalic elements. In the rules formulated by Lébikaza, which are reproduced below, the element /ʁ/ in Rule 24 stands for either of the five elements [ɥ ʉ ʁ ʌ ɑ] while the use of the empty slashes “/ /” in Rule 23 is meant to represent the abstract vocalic element, which could also be represented by the following formula:

$$\begin{array}{c} \text{V} \\ / \left[\begin{array}{l} + \text{ back} \\ - \text{ rd} \end{array} \right] / \end{array}$$

(241) Rule 23 – Lébikaza’s hypothetical Rule 2.a

$$\begin{array}{l}
 // \quad \text{-----} > \\
 \quad \quad \text{-----} > \\
 \quad \quad \text{-----} > \\
 \quad \quad \text{-----} > \\
 \quad \quad \text{-----} >
 \end{array}
 \left\{ \begin{array}{l}
 [\text{ɥ}] / [\text{i}] \text{ ---} \\
 [\text{ɯ}] / [\text{ɪ}] \text{ ---} \\
 [\text{ɤ}] / [\text{e}] \text{ ---} \\
 [\text{ʌ}] / [\text{ɛ}] \text{ ---} \\
 [\text{ɑ}] / [\text{a}] \text{ ---}
 \end{array} \right.$$

(242) Rule 24 – Lébikaza’s hypothetical Rule 2.b

$$\begin{array}{l}
 /ɤ/ \quad \text{-----} > \\
 \quad \quad \text{-----} > \\
 \quad \quad \text{-----} > \\
 \quad \quad \text{-----} > \\
 \quad \quad \text{-----} >
 \end{array}
 \left\{ \begin{array}{l}
 [\text{ɥ}] / [\text{i}] \text{ ---} \\
 [\text{ɯ}] / [\text{ɪ}] \text{ ---} \\
 [\text{ɤ}] / [\text{e}] \text{ ---} \\
 [\text{ʌ}] / [\text{ɛ}] \text{ ---} \\
 [\text{ɑ}] / [\text{a}] \text{ ---}
 \end{array} \right.$$

As remarked by Lébikaza, there are problems with both of these rules: Rule 23) has the disadvantage of being abstract and Rule 24 that of being arbitrary. Moreover, these rules provide very little adequate explanation about why the presumed vocalic phoneme would have such a restricted distribution, only appearing in post vocalic positions and only after the front vowels. Consequently, this hypothesis is discarded.

Since none of the language’s vowels has been confirmed to be the underlying source of the surface elements [ɥ ɯ ɤ ʌ ɑ], the hypothesis that is left to explore

consists in positing that the entity underlying [ɯ ʊ ɤ ʌ ɑ] is none of the vowels but it might be one of the consonants or even something else.

5.2.6.4 The Status of a Phoneme /ɥ/ *vis-à-vis* the Vocalic Elements [ɯ ʊ ɤ ʌ ɑ]

Hypothesis 4: A phoneme /ɥ/ underlies the vocalic elements [ɯ ʊ ɤ ʌ ɑ].

The fourth solution proposed by Lébikaza established a direct link between the elements [ɯ ʊ ɤ ʌ ɑ] and a phoneme /ɥ/. According to Lébikaza (1999: 54-56), the back unrounded vocoids are to be considered as vocalized realizations of a same phonological unit, characterized as the semi-vowel /ɥ/ (“la semi-voyelle /ɥ/”) with which they share the same characteristic features within the vocalic system, namely the features [+back] (“‘arrière’ ([-avant])”) and [-round] (“‘non-arrondi’ ([-arrondi])”). He argued that the semi-vowel /ɥ/ takes the features of the vowel that precedes it. Therefore, such a vocalized form appears as a) a back unrounded vowel when the preceding vowel is an unrounded front vowel (Rule 25 below) and b) is identical to a high back rounded vowel when it follows a back vowel (Rule 26 below). In the context a), the resulting vowel has the [+back] feature of the phoneme /ɥ/ but takes on all the other features of the preceding vowel. This explains why the resulting vowel is of the same aperture and the same [RTR] specification as the front vowel that precedes it. The Rule 25, which applies in the context a) also shows how the five surface vocalic elements can be derived from the phoneme /ɥ/.

(243) Rule 25 – Lébikaza’s Rule 3.a

/ɣ/ -----> [ɰ] / /i/ ___
-----> [ɰ] / /ɪ/ ___
-----> [ɣ] / /e/ ___
-----> [ʌ] / /ɛ/ ___
-----> [ɑ] / /a/ ___

(244) Rule 26 – Lébikaza’s Rule 3.b

/ɣ/ -----> [u] / /u/ ___
-----> [ʊ] / /ʊ/ ___
-----> [ʊ] / /ɔ/ ___

Lébikaza deemed this solution the one that has the most adequate answer to the complex question about the nature of the series of five vocalic elements.

From the perspective of the current study, this last solution of Lébikaza only hints better at the most adequate answer to the complex question raised by the nature of the series of the back unrounded vocalic elements. Indeed, the real answer to this complex question is contained in the last solution of Lébikaza, which, as the author himself pointed out, has the tremendous advantage of explaining the diversity of the vocalic elements that represent the morpheme of the Inaccomplished in this language. But the problem with his solution lies in the actual nature of the phoneme that is reported to underlie the vocalic elements investigated. It is recalled that this alleged phoneme /ɣ/ that was initially reported in the work of Delord (1976) and appeared in

the subsequent studies was not found in Kabiye under the current study. Therefore, a better solution is still needed for the underlying entity of the back unrounded vowels. This solution, which provides a more adequate explanation but was not entertained by previous researchers, including Lébikaza, is presented next in hypothesis 5.

5.2.6.5 The Existence of a Vocalic Archiphoneme /K/ in Kabiye

Hypothesis 5: An archiphoneme in Kabiye underlies the back unrounded vowels

The answer pursued in the current study is the hypothesis of the existence of a vocalic archiphoneme in Kabiye, which is the underlying entity of the back unrounded vocoids [ɯ ʊ ɤ ʌ ɑ] and some of the surface back rounded vocoids [u ʊ]. This archiphoneme, represents an underspecified segment that is underlyingly [-consonantal, +back, -round], but underspecified for height and [RTR] features. This underlying segment is identified as an archiphoneme due to its underspecified nature in the language. The elements [ɯ ʊ ɤ ʌ ɑ] have in common the fact that they are vocalic and carry the features [-consonantal, +back, -round]. All of their other features are predictable on the basis of the preceding vowel. And likewise, the other vocalic elements [u ʊ] of the Inaccomplished aspect carry the features [-consonantal, +back, +round]. It appears that all the elements of the Inaccomplished, which include the second elements of diphthongs [ɯ ʊ ɤ ʌ ɑ] and some [u ʊ], are partially predictable. It is therefore argued here that these segments all derive from this underspecified segment identified as archiphoneme /K/ (or simply “Big K”). It can be said that deriving from the vocalic archiphoneme and the front vowels, the back unrounded vocoids [ɯ ʊ ɤ ʌ

ɑ] have unique features as [- round] and [+ back], among the other back vocoids, which are all both [+round] and [+ back]. Their unique features have kept them from being confused by the previous researchers with any of the other vocoids in the vocalic system.

Under this analysis, /K/ is a vocalic archiphoneme that carries only three features and takes the rest of its features from the preceding vowel. The vocalic archiphoneme is defined as follows:

$$/K/ = \begin{matrix} V \\ \left[\begin{array}{l} + \text{ back} \\ - \text{ rd} \\ - \text{ cons} \end{array} \right] \end{matrix}$$

Hence, after the unrounded front vowels /i ɪ e ε a/, it is realized as the back unrounded vowels [ɯ ʊ ɤ ʌ ɑ] and after the rounded back vowels /o ɔ u ʊ/, it is realized as the rounded back vowels [u ʊ]. The latter realizations [u ʊ] of the archiphoneme /K/ thus completely overlap with the realizations [u ʊ] of the back rounded phonemes vowels /u ʊ/.

This solution was already hinted at in Lébikaza's hypotheses 3 and 4. Lébikaza, unlike any other author, has the merit of establishing a link between the back unrounded vocoids [ɯ ʊ ɤ ʌ ɑ] and some of the surface back rounded vocoids [u ʊ], as deriving all from a same underlying segment, which represents the morpheme of the Inaccomplished in this language. However, Lébikaza's solution, which is presented above as hypothesis

4, needed improvement in the explanation, to pinpoint the true nature of this underlying segment as an archiphoneme. All these vocoids, therefore, derive from the archiphoneme through the application of a single rule, formulated in (245).

(245) Rule 27 – Rule deriving the vocalic elements that represent the vocalic

archiphoneme

$$/K/ \text{-----} > \left\{ \begin{array}{l} [ɰ] / /i/ ____ \\ [ɰ] / /ɪ/ ____ \\ [ɣ] / /e/ ____ \\ [ʌ] / /ɛ/ ____ \\ [ɑ] / /a/ ____ \\ [u] / /u/ ____ \\ [ʊ] / /ʊ/ ____ \\ [ʊ] / /ɔ/ ____ \\ [u] / /o/ ____ \end{array} \right\}$$

Rule 27 collapses Rule 25 and Rule 26 reported from Lébikaza 1999, but for the sake of completeness, Rule 27 is improved to also include the environment after the phoneme /o/, which was not considered in Rule 26 (Rule 3.b of Lébikaza).

The current study largely credits to the studies by Lébikaza the further understanding that some of the rounded vocoids [u ʊ] also derive from the archiphoneme (similar to Lébikaza's /y/) and the back vowels /o ɔ u ʊ/. But the

understanding of the origin of the vocalic archiphoneme can be found in the diachronic analysis of “/ɣ/” by Delord (1976: 445-452).

A full understanding of the origin of the vocalic archiphoneme in contemporary Kabiye is found in the body of the linguistic studies on this language, but especially in the brief diachronic analysis included as annex in Delord 1976. This document examines some Kabiye data of 1854’s listed in an article by Koelle entitled *Polyglotta Africana*, the first work ever found on this language. After comparing these earlier forms to those of today’s Kabiye, Delord determined that some post vocalic [k]’s in general and particularly in the suffixes⁴⁷ *-kʊ* (2nd Genre noun class suffix) and *-ka* (4th Genre noun class suffix) started to soften in earlier dialectal forms of Kabiye. Nonetheless, he notices that the fourth Genre noun class suffix remained *-ka* in some of the substantives here and there without any apparent reason as exemplified by [pɔ́ɖʒíká] ‘scorpion’ and [kùbùkáká] ‘a loud cry’. In post vocalic positions, [k] first softened to [ɣ]⁴⁸ and later, to a hardly perceptible [ɣ] (“*puis en un [ɣ] à peine perceptible*”)⁴⁹. Delord further stresses:

... ce [ɣ] est très peu sensible à l’oreille, si bien qu’il n’a été noté par Koelle que comme un allongement de la voyelle précédente. [...] Ces modifications du phonème /ɣ/ sont d’ordre général; mais dans la

⁴⁷ *-kʊ* and *-ka* correspond to the Singular Class-3 of Type-2 (3SgT2) and the Singular Class-7 of Type-4 (7SgT4), respectively, in the current research (see Table 1.1, in §1.3.3).

⁴⁸ Read either [ɣ] or [ɣ̄]; the author used both notations.

⁴⁹ Lébikaza also mentions a similar vocalization process with the “labial-velar glide [w]” when it forms a diphthong with a preceding vowel (Lébikaza 1999: 127).

conjugaison, /ɣ/ est maintenant difficile à cerner. C'est pourquoi les transcriptions anciennes et actuelles hésitent (Delord 1976: 450 – 451)⁵⁰.

It must be emphasized that though Delord's 1976 consonant system includes a phoneme /ɣ/ that is described as a "velar fricative," Delord himself pointed out how this segment is hardly perceptible to the ear and how it was recorded by Koelle as a vowel.

Lébikaza too noted the following about the segment [ɣ], which he analyzed as the velar approximant phoneme /ɣ/:

La vélaire a beaucoup plus les caractéristiques d'une voyelle dans la mesure où elle est presque toujours vocalisée, ce qui ne lui permet pas d'apparaître en position d'attaque consonantique. Le trait vocalique très prononcé de la vélaire est lié au fait qu'elle résulte d'un processus d'adoucissement de l'occlusive vélaire qui a eu lieu uniquement en position postvocalique (Lébikaza 1999: 123 and footnote 9)⁵¹.

Delord's diachronic study has shed light on the origin of today's proposed archiphoneme. Although it is still not clear if the postvocalic [k]'s that underwent the change belonged to a different phoneme from the phoneme /k/ that still exists in the language today, it is reasonable to believe that the softening of the segment underlying those postvocalic [k]'s has continued. The current vocalic archiphoneme /K/ can be

⁵⁰ "This [ɣ] is very little sensible to the ear, so that it was noted by Koelle only as the lengthening of the preceding vowel. [...] These modifications of the phoneme /ɣ/ are from a general order; but in the verb conjugation, /ɣ/ is now difficult to discern. That is the reason why old and current transcriptions are hesitant."

⁵¹ "...the velar sound [understand [ɣ]] has more of the characteristics of a vowel insofar as it is almost always vocalized, which does not allow it to appear in onset consonant position. The very prominent vocalic feature of the velar sound is due to the fact it derives from a softening process of the velar stop [understand [k]], which took place only in post vocalic position."

connected to the former phoneme “/ɣ/,” which Delord shows to have evolved from some postvocalic [k]s in general, but particularly in the suffixes *-kʊ* and *-ka* (of Class-3 (3SgT2) and Class-7 (7SgT4) nouns, respectively; see Table 1.1). It is to believe that during its phenomenal transformation, the contemporary vocalic archiphoneme may have transitioned through a segment [ɣ], as initially reported in Delord’s work (at least in some parts of the language), that is no longer reflected in the language of today. It has further undergone vocalization, losing all of its consonantal features in the process and is now an underspecified segment with only the features [-consonantal, +back, -round]. There is even reason to believe that its vocalization and underspecified nature were already advanced in the 1850’s as evidenced by the notations of Koelle 1854 that testifies to its vocalic nature and also to some of its features being identical to those of the vowel that it follows.

As regards the notation for this archiphoneme, /K/ is proposed since the choice of the gamma /ɣ/ can be argued to be somewhat problematic for many reasons. First and foremost, the symbol [ɣ] represents a phonetic segment that already has specific and clear articulatory characteristics in the IPA notation that the archiphoneme today no longer meets. Hence, choosing [ɣ] encourages needless confusion. The early fricativized [k] that was represented by [ɣ] or [ɕ] and seen as the phoneme /ɣ/ by Delord has further softened into a vocalic archiphoneme. This would explain why Roberts’ works (2002, 2003) do not include a phoneme /ɣ/, caution the sound [ɣ] in the existing analyses, and use “ɣ” only as “the orthographic symbol ɣ.” Such is an attitude with which the current

study also struggled until the diachronic analysis of Delord shed significant light on this controversial /y/ that is now understood as a vocalic archiphoneme.

The archiphoneme hypothesis has the advantage of explaining many facts about this mysterious phoneme that has raised controversy among the researchers and also about the vocalic system of Kabiye as whole. The understanding of the vocalic nature of the archiphoneme /K/ under the new analysis better explains why this segment (or its phonetic realizations) assumes vowel-like functions within the language. For instance, it can now be understood:

- why the surface elements that represent the archiphoneme bear tone like vowels in this language;
- why the surface elements derived from the archiphoneme seem to be found only after the front vowels /i ɪ e ε a/;
- why the surface elements derived from the archiphoneme are each of the same laryngeal ([RTR]) specifications as the vowel that precedes each of them;
- why each of these surface elements representing the archiphoneme can by itself also represent a meaningful suffix, such as the suffix marking the Inaccomplished aspect and why the surface forms of the latter are so diverse.
- that the vocalic archiphoneme may be being further subjected to other rules that govern vowels in the language, among which vowel harmonies are noteworthy.

This point seems to explain how the forms in the second column in Table 5.11 (page 216) could also come to be pronounced by some speakers with the long

back unrounded vowels as in the third column. It could be interpreted as a further vowel harmony case, whereby the underlying front vowels, in turn, assimilate to the features of the surface-level elements of the archiphoneme. However, these forms could also be rather prefiguring a new set of contrastive vowels that are in turn evolving, in parts of the language, from the phonetically distinct back unrounded realizations [u̠ u̠ ɤ ʌ ɑ] of the archiphoneme. On the other hand, the occurrence in the second column of Table 5.11 of the vocalic elements that represent the archiphoneme in free variation with the phonologically distinctive long front vowels in the first column can be explained in a different way. It is a free variation where we deal with realizations of different phonemes in the same context without a change of meaning: the phonemes /ii ɪ ee εε aa/ in the first column and the vocalic archiphoneme /K/ in the second column.

Finally, it is also understood where the quite mysterious segment /ɣ/ appearing in all the literature and the orthography of Kabiye comes from despite no clear segment [ɣ] found in Kabiye.

5.3 Conclusion of the Revised Vocalic Phonology

This phonological analysis of vowels has shown that from the phonetic inventory presented at the beginning of this research, which includes up to 55 vocoids, 19 vowels are attested at the phonological level. These include nine short vowels /i/ /ɪ/ /u/ /ʊ/ /e/ /ɛ/ /o/ /ɔ/ /a/, nine long vowels /ii/ /ɪɪ/ /uu/ /ʊʊ/ /ee/ /εε/ /oo/ /ɔɔ/ /aa/, and a vocalic

archiphoneme /K/, an underspecified segment with only three features [-consonantal, + back, -round], which underlies many of the vocoids. The Revised Vocalic System is presented in Table 5.12.

Table 5.12 Revised Inventory of Kabiye Vocalic Phonemes

	Set 1: [-RTR]				Vocalic Archi-phoneme	Set 2: [+RTR]			
	FRONT		BACK			FRONT		BACK	
	SHORT	LONG	SHORT	LONG		SHORT	LONG	SHORT	LONG
HIGH	I	ii	u	uu		ɪ	ɪɪ	ʊ	ʊʊ
MID	E	ee	o	oo		ɛ	ɛɛ	ɔ	ɔɔ
LOW						a	aa		
					K				

The contrastive vowel system appearing in Table 5.12 exploits two superposed sets of phonemes and a vocalic archiphoneme that evolved historically from a post vocalic [k] of some suffixes. The two sets of phonemes, which are only differentiated by laryngeal features, constitute nine pairs in that regard, except the two low vowels, which are of the same laryngeal specification. The set 1 vowels, traditionally known as [+ATR] vowels, which lack constriction and retraction of tongue root in their articulation, are now identified as [-CONSTR] or [-RTR] vowels. The set 2 vowels, corresponding to the traditional [-ATR] vowels, which have been shown by recent studies to be produced with pharyngeal constriction and Retraction of Tongue Root ([RTR]) are revised as [+CONSTR] or [+RTR] vowels. The two low vowels belong both to set 2. The vowels of both sets constitute together pairs of nine vowel qualities occurring as short and long.

A vowel formant plot in Bark, of the core nine vowel qualities, based on three repetitions of each vowel, shows the location of these vowels in the acoustic space. The archiphoneme is omitted from the plot since no one of its allophonic instances can fully represent the underlying segment.

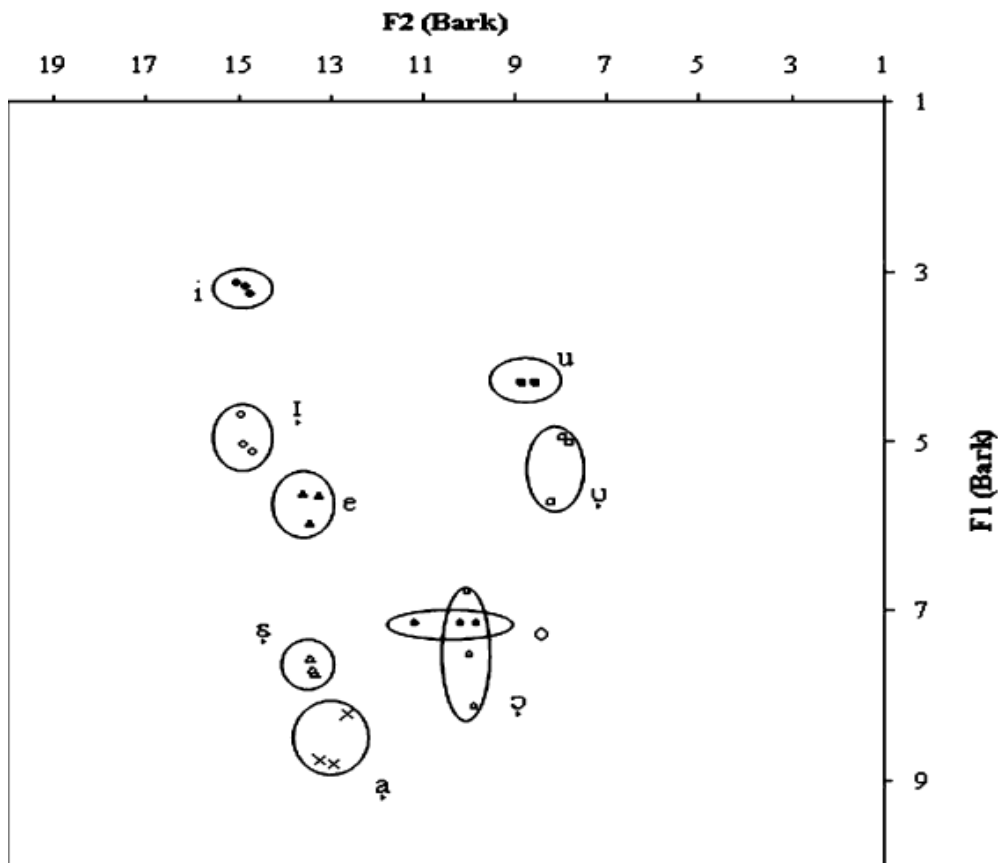

Figure 5.7 Formant Plot of Kabiye Short Vowels in Bark

At the surface level, the phonetically distinct realizations of this dual phonological system merge into a perfectly symmetrical system of 18 short vocoids (or monophthongs) that contrast front versus back. Among these are the realizations of the

underspecified archiphoneme /K/, which occurs only in post vocalic positions, where its surface realizations receive their other features from the preceding vowel. The realizations of the archiphoneme occurring after the unrounded front phonemes /i ɪ e ε a/ or /ii ɪi ee εε aa/, are the back unrounded vocoids [ɯ ʊ ɤ ʌ ɑ], respectively. Although they share many of the features of the front vowels that precede them, their common archiphonemic feature [+back], which differentiates them at the same time from these front phonemes, makes them phonetically distinct from any other vocoids in this system. But the other realizations of the archiphoneme – namely [u] after the back rounded phonemes /u o/ or /uu oo/ and [ʊ] after /ʊ ɔ/ or /ʊʊ ɔɔ/ – merge phonetically with the identical realizations [u] and [ʊ] of the back rounded phonemes /u uu/ and /ʊ ʊʊ/, respectively. The front rounded vocoids [y ʏ ø œ], on the other hand, derive from the back rounded phonemes /u ʊ o ɔ/, respectively, through a palatalization process.

Most of the short vocoids (or monophthongs) can combine into surface-level diphthongs, which may be in fact separated by a glide or a morphological boundary. The phonetic realizations of the archiphoneme in the contexts after the front phonemes and after the non-high back phonemes, in combination with a (morpho-)phonological process that shortens long vowels at morpheme boundary in non-final position (Vowel Shortening rule or VS-rule), produce various surface diphthongs. Similarly, under the effect of the VS-rule, the realizations of the contrastive short and long vowels occurring in sequences of non-identical vowels result in surface-level diphthongs. Only the derived vocoids [y ʏ ø œ] do not enter diphthongization, as opposed to the back

unrounded vocalic sounds [ɥ ʊ ʏ ʌ ɑ], which happen to be the only vocoids always found in diphthongs (as second element) because of their realizations, which are phonetically distinct. Thus, three types of surface-level diphthongs emerge: the diphthongs in first type glide toward an unrounded back vowel; the ones in the second type glide toward a rounded high back vowel; whereas those in the third type glide toward an unrounded high front vowel.

However, surface-level long vocoids or even extra long vocoids can also arise that are not attested at the phonological level, when identical phonemes occur in sequences. Similar to the case of diphthongs, these long and extra long vocoids are always separated by a morphological boundary. Most often, however, extra long vocoids result from an indefinite lengthening inherent to ideophones, which constitute a class of words known to often follow a different phonology than the rest of word classes in the language. Therefore, the extra long vocoids are only attested at the phonetic level.

CHAPTER 6

ACOUSTIC DESCRIPTION AND PHONOLOGICAL OVERVIEW OF TONE

6.1 Introduction

As attested in many studies (Beckman and Pierrehumbert 1986, Connell 1990, Snider 1998, and others), the acoustic analysis framework provides a means for observing and describing the physicality of phonological events manifested phonetically in language use. Hence, there appears to be a fine line between phonology and phonetics, and from the perspective of the interface between these subfields of linguistics, we need to separate those processes that are clearly categorical (phonological) from those that are more gradient (phonetic). However, both subfields complement each other in that phonetics can inform phonology and phonetic investigation of phonological events often result in a better understanding of their nature.

The importance of a phonetic component in the study of Kabiye tone follows not only from documentary reasons but also from the fact that acoustic study of tone can inform us about the phonological properties of this language. Indeed, tone manifested in context possesses sometimes trajectories that differ from its underlying form, as occurs when there is downstep, downdrift, declination. Therefore, a given word's tones vary depending on the tone of what precedes or what follows it. This analysis of tone will

therefore endeavor to describe tone as it is manifested in language use. The initial succinct acoustic study that is presented is aimed at determining the basic characteristics of the physical manifestations of tone. Subsequently, the phonological analysis will uncover the underlying nature of the surface-level tones.

6.2 Acoustic Overview of Tone

This section explores the physical properties of tone through an instrumental investigation of the basic pitch trajectories of the basic tones occurring in the language. The fundamental frequencies, correlates of tone, are also determined.

6.2.1 Physical Nature of Tone

The acoustic investigation of tone reveals that the high tone and the low tone manifest different pitch trajectories and there are variations from speaker to speaker. The pitch tracks and the F_0 values are presented in this section.

From observation of the trajectories of the pitch, a few notes are in order. The pitch tracks quite consistently appear with some disturbance at the syllable onset and the offset, respectively, a generally upward movement (short rise) at onset and a fall with instability at offset. Such perturbations are more noticeable in some pitch tracks than others. It is seen in Figure 6.1, for instance, a very pronounced downward movement at the end of the pitch tracks, which yields a falling contour at odds to the general course of the tracks for a high tone. Since such disturbances consistently appear at the edges of the vowels, it is argued that they are artifactual and not part of the pitch trajectory, but instead are due to the coarticulation influences of the preceding consonant and to the

final effect or artifacts at the end of the word (loss of subglottal air). Besides, in considering the overall fundamental frequency measurements for speakers in the current project, the F_0 values are unexpectedly higher than what would be considered normal for male speakers (Hartmut and Anders 1995 and Hartmut 1995). These unusually high F_0 values may be due to the socio-phonetic effect of “projected,” over-articulated voice of the speakers during data elicitation, which caused their fundamental frequency to be realized at a level higher than would be normal in conversation. Three observations have led to this conclusion: first, the pitch settings in PRAAT were checked to see if they corresponded to expected values of the pitch range; second, using the zero crossing point as a criterion, the duration of ten periods of the wave form were determined, which allowed the frequency to be calculated; and third, the minimum and maximum values in semitones were checked to see if they corresponded to one octave (which equals 12 semitones), the natural pitch range of the voice. The high F_0 values, however, were not found to have any bearing on the pitch trajectory.

6.2.1.1 The F_0 trajectory of the High Tone and the Low Tone

In this investigation of the acoustic nature of tone, which distinguishes between tone (high tone and low tone) on short vowels and on long vowels, there were variable pitches for high tones and low tones, but representative examples are shown for illustration. The F_0 values of low tones and high tones were extracted and the pitch tracks plotted.

Figure 6.1 displays the extracted pitch tracks of a high tone on a short vowel in three repetitions of the word [tú] ‘elephant’ produced by speaker 1. In the first repetition, which is highlighted, it can be seen that the trajectory of the pitch tracks of the high tone (H) on a monosyllable uttered in isolation shows a slight rise from the onset to the offset.

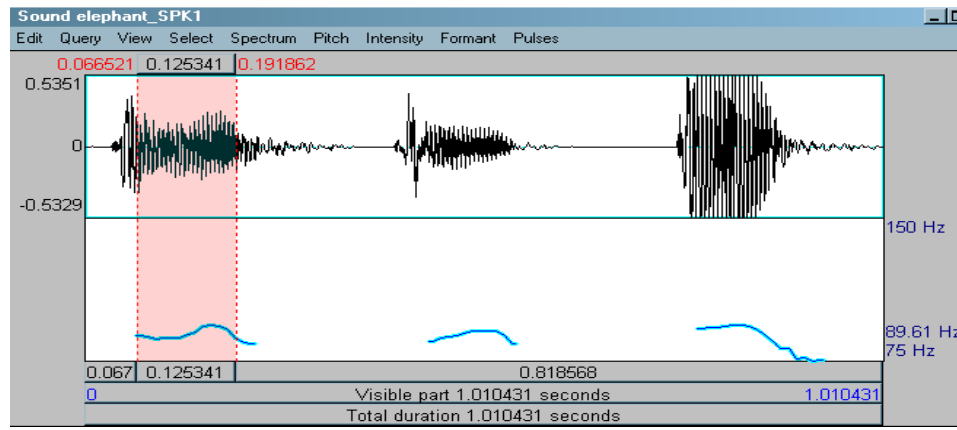

Figure 6.1 Pitch tracks of the high tone [H] on the short vowel [u] in [tú] ‘elephant’

Figure 6.2 shows the pitch tracks of the [HH] tone sequence on the word [tʃíí] ‘tear-IMP’, also from speaker 1 (SPK1).

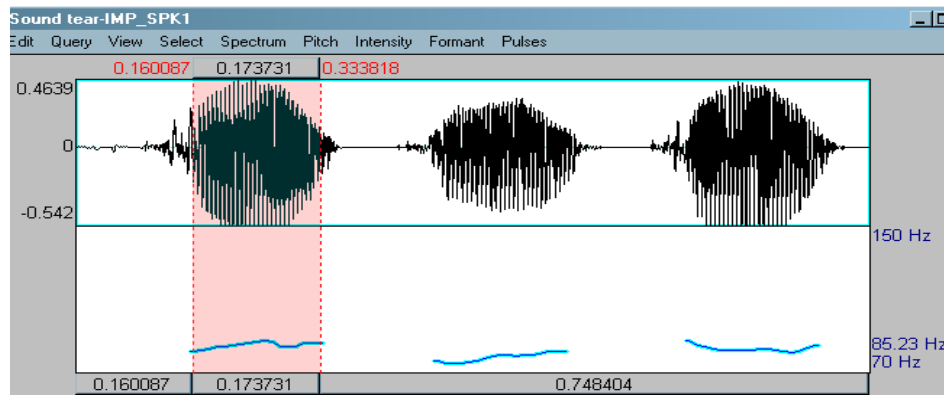

Figure 6.2 Pitch tracks of the [HH] tones on the long vowel [ɪ] in [tʃíí] ‘tear-IMP’

The pitch track of consecutive high tones ([HH]) on a long vowel (Figure 6.2) has the same general appearance as the pitch track of [H] tone on a short vowel, with the only visible difference being a significantly longer duration. It can be seen from the selected repetition in Figure 6.2 that the pitch tracks also show a slight rise at the onset and a slight fall at the offset.

The F_0 values of the [H] and the [HH] at vowel onset, at mid-vowel, and at vowel offset are comparable (mean values for three repetitions given here). The pitch track of the high tone [H] of SPK1 in Figure 6.1 originates at a mean value of about 174 Hz, and rises steadily to an F_0 of 185 Hz before it falls to 154 Hz. The F_0 of the pitch tracks of the [HH] of the same speaker (Figure 6.2) was measured at 162 Hz at vowel onset. It rose to a maximum value of 170 Hz and fell to 160 Hz. A similar pattern is observed with the fundamental frequency of the other speakers in this research, who tend to have a higher F_0 than SPK1. The F_0 of the pitch tracks of the [H] of speaker 2 (SPK2) for example, was 200 Hz at onset, around a maximum of 220 Hz at mid-vowel, and at a low value of 198 Hz at vowel offset. The F_0 of his [HH] tones was 194 Hz at onset and 208 Hz at vowel offset, after a maximum of 214 Hz. For all the speakers, the [H] tone was realized between the values of 184 Hz at onset and 227 Hz at offset, with a maximum value of 242 Hz. Their [HH] tones values were 209 Hz at onset and 216 Hz at offset through a maximum value of 223 Hz. In general, the variation of the [H] and the [HH] in regard to F_0 values does not differ significantly.

The pitch tracks of a low tone on a short vowel are shown in Figure 6.3 below.

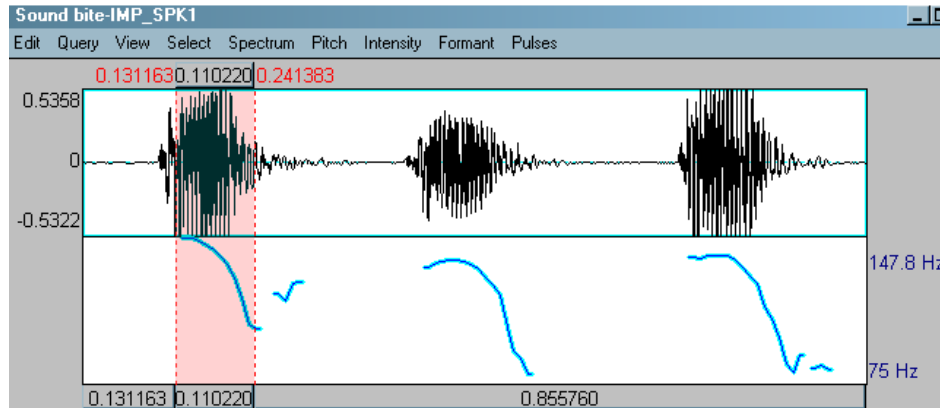
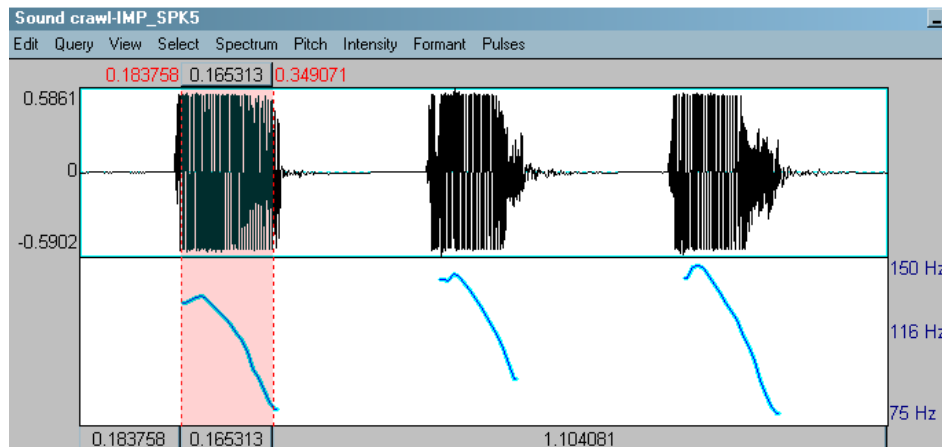

Figure 6.3 Pitch tracks of the [L] tone on the short vowel [ʊ] in [tʊ] ‘bite-IMP’

The trajectory of the pitch tracks of the low tone [L] on a short vowel is manifested with a pitch track opposite to that of the high tone. Appearing in Figure 6.3 are the pitch tracks of a [L] tone on the vowel [ʊ] produced by SPK1 in the imperative form of the word [tʊ] ‘bite’. The [L] tone trajectory shows a fall from onset to offset. The fall in the tracks is steady at the beginning and steeper toward the end.

On a long vowel, the pitch tracks of the [LL] tones, shown in Figure 6.4, have a general trajectory that is similar to the single low tone.



(a)

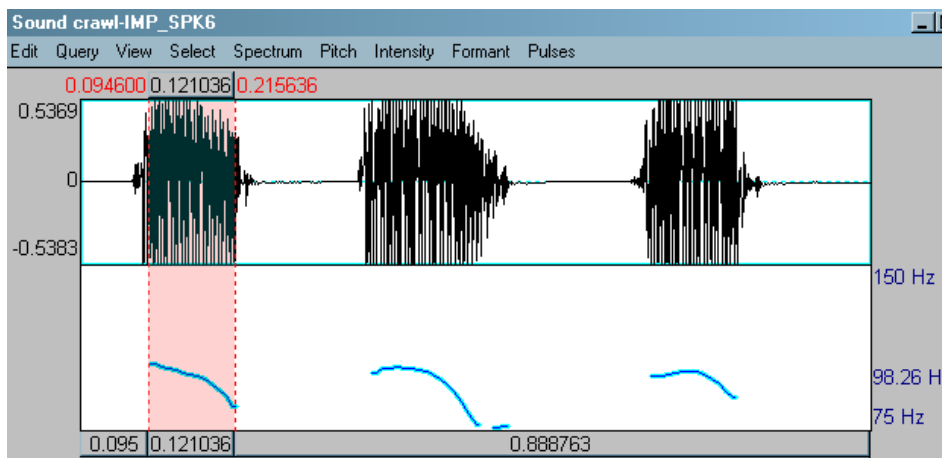

(b)

Figure 6.4 The Pitch tracks of the low tones [LL] on the long vowel [uu] demonstrate a lesser slope in (a) and a more abrupt fall in (b) for [tù] ‘crawl-IMP’

The general trajectory of the pitch tracks of the [LL] tones on a long vowel show a steady fall, illustrated with the imperative form for ‘crawl’ in Figure 6.4 (for two speakers). However, the general falling trajectory of the pitch tracks of the [LL] tones varies depending on the speaker. For the majority of the speakers in the study, the fall

in the pitch tracks has an abrupt downward slope as illustrated by the pitch trajectory of speaker 5 (SPK5) in Figure 6.4 (a), whereas for a few other speakers, e.g. speaker 6 (SPK6) in Figure 6.4 (b), the fall is less steep. It is also noticeable that the slope of the pitch tracks of the [LL] tones is greater for SPK5 than for SPK6. The pitch tracks of speaker 2 (SPK2, not shown), presented an unusually small fall, with an almost level appearance. Moreover, though the long vowels were produced with variable duration by the speakers, the timing of the long vowels in ‘crawl’ by SPK2 was noticeably longer than other speakers. SPK2, therefore, can be considered an idiosyncratic pattern, deviating from the norm of the rest of the subjects.

The [LL] on a long vowel was determined to be produced at higher frequency values than the [L] on a short vowel. The mean value of the [L] tone’s F_0 for SPK6 (Figure 6.3) was determined to originate around 195 Hz. It then rose to about 202 Hz and fell to as low as 166 Hz. For all the subjects, the [L] tone’s pitch tracks originated around 175 Hz and fell below 123 Hz after a light rise at 187 Hz. For the [LL] tones on the long vowels, SPK5’s repetitions (Figure 6.4 (a)) originated at an value F_0 of 219 Hz and fell around a value of 140 Hz at vowel offset. The mean values of the repetitions at onset, at mid-vowel and at vowel offset for all subjects were 175 Hz, 123 Hz, and 187 Hz, respectively.

There did not appear to be variation of any significance in the beginning F_0 values of the low tones and the high tones, but the generalization to note is that low tone trajectories are falling to the lowest point in the syllable, whereas high tones demonstrated a nearly level trajectory.

We next examine the pitch tracks of the [HL] and the [LH] to determine their physical nature and their acoustic characteristics.

6.2.1.2 Trajectory and Fundamental Frequency of the High-Low and the Low-High Tone Sequences

There are succession of pitches in Kabiye, which may be regarded as sequences of High-Low (HL) and Low-High (LH), realized phonetically on long syllables, i.e., long vowels, consecutive vowels, or consecutive nasals in syllable peak and coda positions. In this sequence of pitches on consecutive or long Tone Bearing Units (TBUs), the first part is aligned with the first TBU and the second part with the second TBU. The autosegmental understanding of contour tones as combinations of H and L tones can nicely account for these features.

To determine the trajectory of HL, pitch tracks of three repetitions of the word [ɲ̀ɔ̀tɔ̀ù] ‘to connect’ were extracted. This two-syllable-word ends in a surface-level long vowel that is associated with HL in the second syllable (cf. the selection in the first repetition in Figure 6.5).

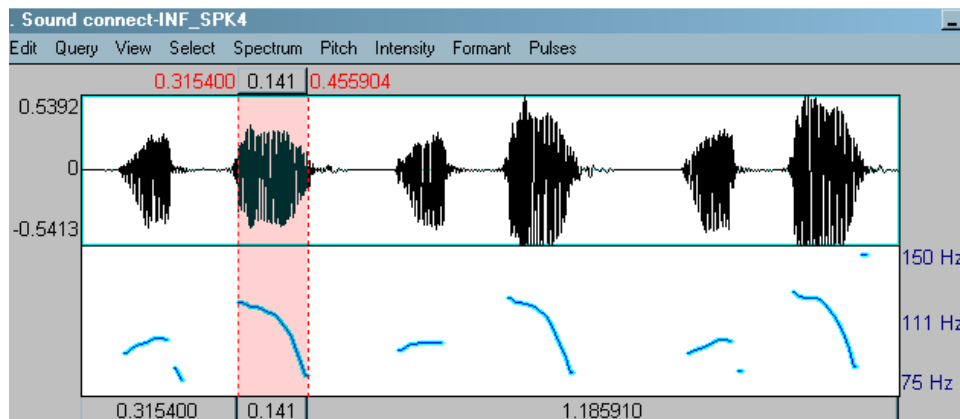

Figure 6.5 Pitch tracks of the high-low [HL] tone sequence on a long vowel [ɔ̀] in [ɲ̀ɔ̀tɔ̀ù] ‘connect-INF’

For the three repetitions shown in Figure 6.5, the pitch tracks of the long vowel start high and fall very low, with a slow fall in the first half of the long vowel and a much steeper fall in the second half of the long vowel. It should also be noticed that the pitch tracks do not show a rise at onset before they fall, nor do they fail to fall anywhere in the second half of the vowel. The trajectory of the [HL] is unlike the one observed in the rise of the pitch tracks of the low-high tone sequence (cf. Figure 6.6).

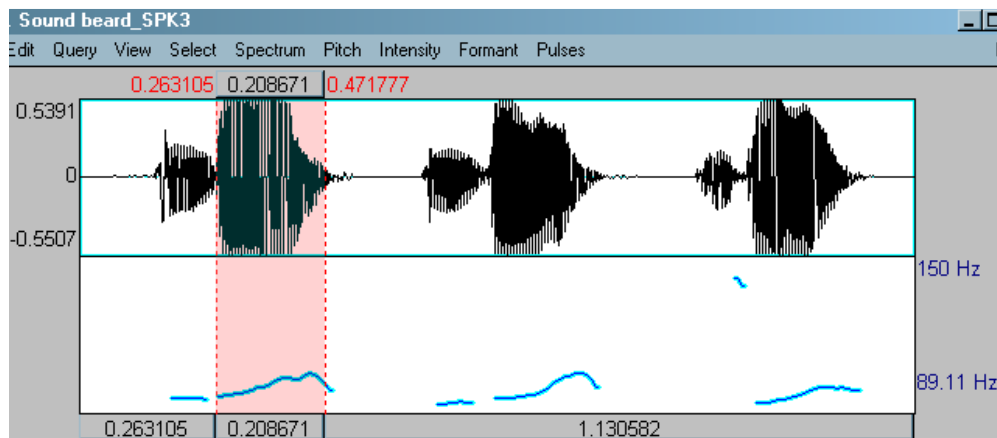

Figure 6.6 Pitch tracks of the low-high [LH] tone sequence on a long vowel [ʊʊ] in the word [tànɔ̀ù] ‘beard’

The pitch track of the [LH] sequence on the final long vowel (see selection in the second syllable of the first repetition in Figure 6.6) rises progressively through the course of the vowel to a slightly higher position at the end. The rise, which starts from the origin, is slower in the first half of the vowel in each of the three repetitions. In addition, it can be observed that [LH] does not have the inverted trajectory of the [HL] shown in Figure 6.5, but the fall in the second half of [HL] is steeper than the rise in the second half of [LH]. Ergo, one might say the low falls more than the high rises.

It can be concluded that the trajectory of [LH] and [HL] does not exactly equal a sequence of a H tone and then a L tone. While the [LH] does approximate a rising contour, it rises only slightly. Analogously, the [LH] and the [HL] tones do not have inverted trajectory, the one from the other, as corroborated by the F_0 tracks.

The fundamental frequency of the pitch of the [HL] and of the [LH] was measured for all the subjects. For the [HL] of SPK4 in Figure 6.5, the mean F_0 of the three repetitions was determined to be 249 Hz at the onset and at 151 Hz at the offset. For all seven speakers, the F_0 of the [HL] pitch track began between 343 Hz and 159 Hz and fell between 163 Hz and 91 Hz. The mean pitch F_0 of SPK3 for the [LH] (Figure 6.6) was determined at onset of the long vowel at 164 Hz and at offset at 184 Hz. For all seven speakers, F_0 of the [LH] pitch track originated between 140 Hz and 187 Hz and rose to 245 Hz for the lowest value and 343 Hz for the highest.

This acoustic investigation has allowed us to determine the physical characteristics of tones, especially the trajectory of their pitch tracks and the fundamental frequencies at which they are produced. The examination of F_0 values reveals that the high tone and the low tone manifest pitch trajectories systematically incongruous to the names HIGH and LOW, and there was also variation within these two patterns. Generally, the pitch trajectory of the high tone manifests a rise whereas the one of the low tone manifests a fall. Though the pitch trajectory of the high tone or the low is similar for all the speakers, it also varies slightly from speaker to speaker. From F_0 measurements, it is apparent that not only is there intra-speaker variation for

[H] tones and for [L] tones but there is also inter-speaker variation as well. The pitch tracks of the [LH] and [HL] tones are not manifested by a rise followed by a fall and a fall followed by a rise, respectively, nor do they have mirror-image trajectories. It can also be deduced from the pitch trajectories and F_0 measurements that what the grammar characterizes as a H tone, a L tone, HL tones or LH tones is acoustically relative in that they have varied trajectories and cover a range of acoustic adjustments for the same speaker and across speakers.

Nevertheless, all the speakers were targeting only one phonological category for each type of tone during the production of their instances of [H], [L], [HL], and [LH] tones. The following discussion will turn from surface-level tones manifested in words to a phonological analysis of these instances as attested in the underlying system of Kabiye tone.

6.3 Phonological Analysis of Tone

This phonological analysis seeks to determine the underlying tones that are manifested in the acoustic data. These include the distinctive and the lexical tones of the main Kabiye morphemes (verb roots, noun roots and affixes). The main tonal alterations that occur in morphemes combinations into lexical items are also discussed.

6.3.1 Distinctive Tones and the Tone-Bearing Unit

In order to address the question as to what underlying tonal categories there are, the study needs to identify among the inventoried tones that were described earlier in the acoustic overview, the ones that are distinctive. In doing so, the study must also

seek to find out if the tones manifested acoustically as [H], [L], [HL], and [LH] match systematically with some corresponding underlying high, low, high-low, and low-high categories, respectively or if some of the surface tones belong to different underlyingly categories. But before looking at the tone itself, it is important to clarify first what qualifies as TBU in this language.

6.3.1.1 The Tone-Bearing Unit

The current study agrees with earlier researchers on Kabiye (such as Lébikaza (1999), Kassan (1996), Roberts (2002), and others), who are unanimous in arguing that the mora is the Tone-Bearing Unit (TBU). However, which segments exactly qualify as TBUs in the language is controversial, and the view of the current study on that more specific matter is slightly different from theirs.

In Kabiye, segments occurring in syllable peak and syllable coda positions bear tone (T). As borne out in previous studies (Ladefoged 1975: 224, Hyman 1975: 232), the short syllable corresponds to one mora and the long syllable to two morae. Syllable peak and syllable coda segments in Kabiye, therefore, count each a mora. Though the researchers are in agreement that the TBU in Kabiye is not just the vowel, various other segments have been attributed tone bearing function in certain contexts in previous studies: [m], [ŋ], [w], [j], and [ɣ], in syllable coda position (Lébikaza 1999, but not [j] in Delord 1976), [m], [n], [ŋ], and [ɲ], before a consonant (Lébikaza 1999, Roberts 2003b).

The findings of the current study disagree with coda glides, but expand the list of nasals that qualify as TBUs in pre-consonantal positions. Following in the steps of Roberts, the current study treats other researchers' syllable coda [w], [j], and [ɣ] as vowels (see arguments about syllable structure in §1.3.4, and analysis of vowels in §5.2). With respect to nasals, it is argued that all the nasals occurring in pre-consonantal position function as syllable peaks and are TBUs in this position. This includes not only [m], [n], [ɲ], and [ɳ], but also [ŋ], [ɱ], and [ŋ̄m]. This position aligns with the analysis of nasals in §4.3.3, which has shown that all the nasals manifested at the surface-level can occur in pre-consonantal position. This study, however, agrees with all previous studies by positing [m] and [ŋ] as the only nasals found in word-final position where they are also TBUs. Beside vowels and nasals, one can also add [r], which can occupy syllable peak or coda positions in ideophones. Examples (246) – (248) provide an illustration of TBUs that are vowels, nasals, and rhotics (in ideophones), respectively.

(246)

- a. [tùmíjè] 'the work'
- b. [sðójè] 'mortar'
- c. [pìsàú] 'cloth'

(247)

- a. [sððńdù] 'fear'
- b. [sàmtù] 'praises'
- c. [jòń] 'slave'
- d. [sóŋ] 'a bad smell'
- e. [ŋgùlímìjé] 'fist'
- f. [ŋ̄mgbám] 'termite'
- g. [mbòń] 'cassava'
- h. [m-màbá] 'you beat'
- i. [ŋ-ŋ-dèè] 'you would leave'

(248) [kùr̀̀̀̀] or [kúr̀̀̀̀] ‘(very) straight’

From a phonetics and phonology interconnection perspective, it can be pointed out that the nasals occurring in pre-consonantal positions as syllable peak or syllable coda segments are mainly surface manifestations of the nasal archiphoneme /N/. Knowing that pre-consonantal positions are usually associated with vocalic positions in Kabiye is key in understanding why pre-consonantal nasals can bear tone.

In sum, the vowel is the fundamental TBU in Kabiye. But all nasals in pre-consonantal positions as syllable peak and syllable coda and the nasals in word-final position also function as TBUs.

6.3.1.2 Distinctive Tones

On the surface, Kabiye has both H and L tones, the former marked by an acute accent, the latter unmarked. Both HL and LH tonal contours occur in the language, but only on CVV syllables. In addition, there is a downstep ('H) phenomenon. Only two distinctive tones exist in Kabiye, though more surface tonal heights can be determined in the word and in larger syntactic units. To determine the distinctive tones, the surface tonal heights occurring in the phonological word are examined, since it can safely be assumed that all the distinctive tones will be manifested in this unit.

Kabiye contrasts only two level tones: the /H/ tone and the /L/ tone, which manifest themselves in the word as [H], [L], and a downstepped high tone (Roberts 2002, Lébikaza 1999) that Lébikaza identifies as [M] or surface-level mid tone. Some words manifest only [H] tones (249), others, only [L] tones (250). Still other words

manifest different pitch levels, which can occur in specific combinations in the word as [H] and [L] (251), [H] and [M] (252), or [H], [M], and [L] (253), but no combination of [L] and [M] exists. The [M] is shown in the examples by a macron over the vowel.

(249) [H] words

- a. [tú] ‘elephant’
- b. [kólú] ‘blacksmith’

(250) [L] words

- a. [li] ‘swallow!’
- b. [èjàbìjè] ‘banana’

(251) Words of [H] and [L] combination

- a. [èjú] ‘person’
- b. [kṙínè] ‘animal’
- c. [kṙèlíṅ] ‘vultures’

(252) Words of [H] and [M] combination

- a. [kṙíjīŭ] ‘canoe’
- b. [kílēmā] ‘dried ones’
- c. [sómōlā] ‘papayas’

(253) Words of [H], [M], and [L] combination

- a. [séjīnāà] ‘grandchildren’
- b. [kàndílāū] ‘(a type of) pea’

Downstep has been described in Kabiye as related to downdrift, both of which occur as a result of a single phenomenon (Lébiakaza 1999, and Roberts 2002, 2003a, 2003b). According to Roberts, downstep and downdrift result from a “lowering of tonal register” every time a H tone follows a L tone, with the H tone surfacing on a register lower than that of a preceding H. He refers to this phenomenon as “automatic

downstep” when it is triggered by an associated tone and as “non-automatic downstep,” when it is triggered by a floating tone. Lébikaza points out about this phenomenon, also referred to as “HLH plateauing” by Roberts, as always triggered in /HLH/ sequence, with the /L/ and the second /H/ realized at the same level as [MM].

All the words with [M] tone combinations found in the data used for the current analysis lend themselves to this understanding of downstep by Roberts and Lébikaza. In the forms in (253) and (255) above, it is determined that the [M] can always be derived from an underlying /L/ occurring between two /H/ tones, in which case it is more appropriate to transcribe these forms with downstep as in (254) and (255). The intervening /L/ between the /H/ tones is determined from the tones of the underlying forms in the internal structure of the words, which is also confirmed by singular forms of nouns.

(254)

- a. /kᵑíjì -Ú/ [kᵑí'jìú] ‘canoe’
 canoe - 3SgT2
- b. /kí- lèm -á/ [kí'lémá] ‘dried ones’
 Adjᵑ dry -Acc
- c. /zómòl -á/ [só'mólá] ‘papayas’
 papaya 6PIT3

(255)

- a. /séj -ì -náà/ [sé'jínáà] ‘grandchildren’ (cf. [séjì] ‘grandchild’)
 grandchild -EpV -2PIT1
- b. /kàndíl -àK/ [kàndí'láú] ‘(a type of) pea’ (cf. [kàndí'lásì] ‘(type of) peas’)
 pea -7SgT4

Following others researchers, including Lébikaza and Roberts, it is concluded that the /H/ and the /L/ are the only contrastive tones in Kabiye. The position of these underlying tones relative to each other in the word, results into a third surface-level pitch, which is phonologically analyzed as a downstepped high tone, though other phenomena or tone alterations can rise in units beyond the word. Therefore, this analysis has not confirmed the underlying /M/ of Paaluki 1995 nor the /LH/, /HL/, /LL/, and /HH/ of Delord 1968, and 1976 (cf. Table 2.12).

The underlying /H/ and /L/ tones can occur in specific combinations on morphemes. Only a few such combinations exist for in each type of morphemes of the languages, which constitute their lexical tonal melodies. Hence, roots and affixes in the word can have their own lexical tonal melodies. The tonal melodies of noun roots and verb roots, and those of noun suffixes are determined next and the derivation of surface tones of nouns and verbs shown.

6.3.1.3 Tone Association Conventions and Tone Rules

The Autosegmental theory initially proposed in Goldsmith 1976 and further developed in others works (Clements and Ford 1979, Pulleyblank 1986 and others) can be used to account for the surface realizations of the underlying /H/ and /L/ combinations in Kabiye words. It is suggested, along the line of this theory, that in the word formation process, Ts on the tonal tier of the morphemes (roots and affixes) of the word come to be associated with TBUs on the segmental tier.

As Hyman & Ngunga 1994 put it, “One of the major aims of linguistic theory is to determine what is universal vs. language-specific within grammatical systems. [...] In his original Autosegmental theory, for instance, Goldsmith (1976) provided a formalism and a set of principles embodying a number of universal claims about how different tiers may link to each other.” Hyman & Ngunga summarize the relation of tones to TBUs and to each other in Goldsmith (1976) as in (256):

(256) Autosegmental tonology (Goldsmith 1976)

- a. Association convention: map free Tones to free TBUs one-to-one, left to right.
- b. Automatic contouring: map any remaining free Tones to the rightmost TBU (every Tone must be linked to a TBU).
- c. Automatic spreading: spread the rightmost Tone rightwards onto any remaining free TBUs (every TBU must be linked to a T).
- d. Line-crossing constraint: association lines may not cross.”

But, since Goldsmith’s pioneering work, the four original principles summarized in (256) have been reinterpreted so that the theory can apply to other languages, which did not appear to follow all the (arguably) universal principles initially determined by Goldsmith. It has been claimed that tones are mapped differently in some languages and all languages do not follow the same rules. Therefore, tone association rules have to be specified for each language. For instance, it has been shown that there is no automatic contouring; instead, contouring, rather than being universal, is a language-specific option (Clements & Ford 1979). It has also been shown that there is no automatic

spreading; spreading is also a language-specific option (Pulleyblank 1986). In later works, it has been argued that “*all* tonal associations are to be accomplished by language-specific rules, rather than by universal convention” (Hyman & Ngunga 1994).

The tone system of Kabiye appears to also support many of these claims. Following in the footsteps of others who have replaced earlier claimed universals ('automatic contouring', 'automatic spreading') by well-motivated language-specific rules, the tone association rules in (257) are determined to apply in the case of Kabiye.

(257) Kabiye tone association rules:

- a. Tone association: associate Ts in the melody to the TBUs in their corresponding morphemes, left to right, one to one,
- b. No contour constraint: multiple linking of Ts to a TBU is not allowed.
- c. Tone Spreading: spread Ts rightward in the word; if there are any remaining Ts unassociated, spread Ts leftward (every T must be unassociated to a TBU).
- d. Well-formedness condition: association lines may not cross.
- e. Obligatory Contour Principle (OCP)
- f. Vertical assimilation⁵²: register lowering occurs in a HLH sequence
- g. Downstep: downstep follows a register lowering.

The left to right mapping of Tones to TBUs (here morae) is shown in (258).

⁵² Term used by Lébikaza (1999) and Roberts (2002, 2003) to describe this process.

(258) Rule 28 – Tone mapping rule (left to right)

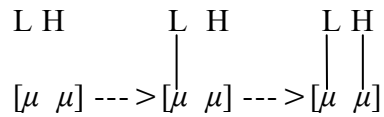

The no ‘automatic contouring’ constraint in (257)b disallows multiple linking of Ts to a single TBU (at least in the surface form of a word): a T must be linked to only one TBU. However, a T may be linked to multiple TBUs. The contour tone simplification rule formalized in (259) applies to repair violations of this constraint.

(259) Rule 29 – Contour Tone Simplification rule

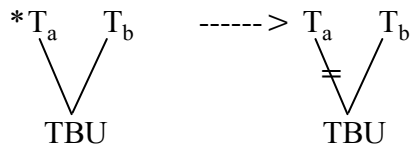

Tone spreading can occur both Left-to-Right and Right-to-Left in Kabiye. Tone spreads in the word until it reaches a TBU that is already associated. Some languages prefer to apply H Tone Spreading (HTS) and L Tone Spreading (LTS). In Kabiye, both the /H/ the /L/ also spread. However, rather than HTS or LTS, most important is the directionality of the spreading. Therefore, we formalize in Kabiye tone spreading rules in terms of Left-to-Right Spreading (260) and Right-to-Left Spreading (261).

(260) Rule 30 – Left-to-Right Spreading rule (L → R S)



(261) Rule 31 – Right-to-Left Spreading rule (R → L S)

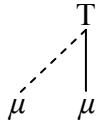

Downstep can be caused by an overt L (automatic downstep) or a covert L (non-automatic downstep): a singly linked L between two Hs delinks and the following H, with its lowered register, spreads left onto the toneless TBU. Downstep occurs in Kabiye in HLH sequences, when the L is singly linked. Downstep is formalized in (262):

(262) Rule 32 – rule of downstep

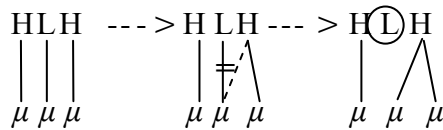

The Obligatory Contour Principle (OCP) constrains against adjacent identical tones. Kabiye uses merging of adjacent identical Ts to repair OCP violations and this process applies whenever it can in the derivation.

Autosegmental theory, hence, permits three ways in which a morpheme appears in the lexicon: as a sequence of segments (a morpheme without underlying tone); as a tonal melody without segmental support (a floating tone); or – most commonly – as a sequence of segments associated to a tonal melody. In the derivation of nouns and verbs in this work, the tone mapping rules in defined (257) apply in the following order:

1. Root
2. (Morpho)phonological changes

3. Initial association of Ts in the tonal melody to the TBUs in their corresponding morphemes.
4. Delinking (Contour simplification)
5. Left-to-Right Spreading (L → R S) of HTS & LTS
6. Right-to-Left Spreading (R → L S) of HTS & LTS
7. Merging (OCP repair)
8. Vertical assimilation (register lowering)
9. Downstep
10. --- > Surface forms

Tone derivations are based on two important principles.

First, a rule that applies in the derivation of a noun must also apply in the derivation of all the nouns and verbs, whenever the conditions are met. But in reality, the effect of the rule might not be seen.

Second, the rules always apply in the same order. All the rules are assumed to apply in the derivation of each word. However, any step in which the application of a given rule has no effect in any of the forms shown will be skipped, as the rule is assumed to have applied vacuously.

6.3.2 Tonal Melodies of Noun Roots

In Kabiye, given any particular underlying tonal melody that may be associated with a noun root, the surface tonal pattern of the noun root is predictable, regardless of which class the noun belongs to (and hence, regardless of which suffix is attached to the noun root). In the three contexts specified in the methodology (i.e., in isolation, after an

H-toned pronoun, and after an L-toned pronoun), it is observed that the surface tones of noun roots behaved in five different ways, on the basis of which the underlying tonal melodies of noun roots are determined. Examination of the surface tonal patterns of nouns in these contexts reveals five groups of noun roots on which four tonal melodies are uncovered.

6.3.2.1 High Melody Noun Roots (/H/ roots)

The surface form of the nouns in the first group of roots always carry a high tone on their roots irrespective of the tonal melody of the suffixes and whether the nouns occur in isolation or in included position. The roots in this group are usually monosyllabic and may be suffixless or take suffixes with various tonal melodies. The singular and plural nouns in (263) are examples.

(263)

Isolation Noun (N)	After L tone	After H tone	Underlying Noun Tones	Gloss
[sùù]	[pù- zùù]	[nú- zùù]	/sù -Û/	‘tail’
[sùh̃]	[pù- zùh̃]	[nú- zùh̃]	/sù -´Ñ/	‘tails’
[tù]	[pù- dú]	[nú- dú]	/tù -ø/	‘elephant’
[tùh̃]	[pù- dúh̃]	[nú- dúh̃]	/tù -´Ñ/	‘elephants’
[kójè]	[pò- gójè]	[nó- gójè]	/kój -È/	‘medicine’
[kó]	[pò- gó]	[nó- gó]	/kój -ø/	‘medicines’
[tù]	[pà- dú]	[ná- dú]	/tù -ø/	‘bee’
[tùh̃]	[pà- dúh̃]	[ná- dúh̃]	/tù -´Ñ/	‘bees’

For the nouns illustrated by (263), it is proposed that their roots carry an underlying /H/ tone, as witnessed by the surface form of the nouns, which always carry a high tone on the roots. The tones of the suffixes, which are attached to the roots as

shown in the fourth column, are determined as /L/ for the singular suffixes and /HL/ for the plural suffixes. Some of the singular and plural nouns are suffixless (with \emptyset representing the zero suffix, which has no underlying tone). The principles and steps of derivation determined in the preceding section apply to derive the surface singular and plural forms in (263). Assuming that the underlying tonal melodies of all regular noun roots are identical for the singular nouns and their plural counterparts (since both look similar), a step by step sample derivations of the forms of ‘elephants’ and ‘tail’ are shown in Table 6.1 and Table 6.2, respectively.

Table 6.1 Derivation of the Plural Form for ‘elephants’

Underlying form	H-HL tu-N	L-H-HL bU-tu-N	H-H-HL ɲU-tu-N
(Morpho)phonological change	H-HL tu-ŋ	L-H-HL bu-tu-ŋ	H-H-HL ɲu-tu-ŋ
Initial association	$\begin{array}{c} \text{H} \quad \text{-HL} \\ \quad \diagdown \\ [\text{tu}] \quad [\text{ŋ}] \end{array}$	$\begin{array}{c} \text{L} \quad - \quad \text{H} \quad \text{-HL} \\ \quad \quad \diagdown \\ [\text{pu}] \quad [\text{du}] \quad [\text{ŋ}] \end{array}$	$\begin{array}{c} \text{H} \quad - \quad \text{H} \quad \text{-HL} \\ \quad \quad \diagdown \\ [\text{ɲu}] \quad [\text{du}] \quad [\text{ŋ}] \end{array}$
Delinking (Contour simplification)	$\begin{array}{c} \text{HHL} \\ \quad \diagdown \\ \text{t} \quad \text{u} \quad \text{ŋ} \end{array}$	$\begin{array}{c} \text{L} \quad \text{HHL} \\ \quad \quad \diagdown \\ \text{pu} \quad \text{du} \quad \text{ŋ} \end{array}$	$\begin{array}{c} \text{H} \quad \text{HHL} \\ \quad \quad \diagdown \\ \text{ɲu} \quad \text{du} \quad \text{ŋ} \end{array}$
Merging (OCP repair) ---> Surface forms	$\begin{array}{c} \text{HL} \\ \quad \\ \text{t} \quad \text{u} \quad \text{ŋ} \end{array}$	$\begin{array}{c} \text{L} \quad \text{HL} \\ \quad \quad \\ \text{pu} \quad \text{du} \quad \text{ŋ} \end{array}$	$\begin{array}{c} \text{H} \quad \text{L} \\ \diagup \quad \diagdown \\ \text{ɲu} \quad \text{du} \quad \text{ŋ} \end{array}$
Transcription	[túŋ] ‘elephants’	[pù-dúŋ] ‘their elephants’	[ɲú-dúŋ] ‘your elephants’

Table 6.2 Derivation of the Singular Form for ‘tail’

Underlying form	H-L su-U	L-H-L bU-su-U	H-H-L ɲU-su-U
(Morpho)phonological change	H - L [su][u]	L- H -L [pu-[zu][u]	H - H -L [ɲu][zu][u]
Initial association	H L [su][u]	L H L [pu][zu][u]	H H L [ɲu][zu][u]
Merging (OCP repair)	NA	NA	H L N ɲuzuu
--- > Surface forms	H L suu	L HL puzuu	H L N ɲuzuu
Transcription	[súù] ‘tail’	[pù-zúù] ‘their tail’	[ɲú-zúù] ‘your tail’

Table 6.1 and Table 6.2 show tone association in /H/ root that have /HL/ and /H/ melodies on the suffixes, respectively. For the derivation of ‘elephants’, the initial association of tone, which proceeds from left to right, dumps an extra tone on the single TBU of the suffix, creating a contour on the right edge of the noun, in violation of the ‘No contour constraint’ in (257)b; therefore, the Contour Tone Simplification in (259) applies to repair the violation. However, the association also creates sequences of identical tones, which triggers OCP repair through merging of the identical tones. The tone association in ‘tail’ creates only an OCP violation, which is also repaired by merging. In both monosyllabic roots, no tone spreading can be observed.

6.3.2.2 Low Melody Noun Roots (/L/ roots)

This class of noun roots surface with a low tone or low tones on every mora of the roots. This tonal pattern is unaltered, whether the nouns occur in isolation or in included position after an L-toned morpheme and after an H-toned morpheme. (264) illustrates these nouns.

(264)

Isolation Noun (N)	After L tone /bÀ/ ‘their’	After H tone /nÁ/ ‘your’	Underlying Noun Tones	Gloss
[̀ǹz̀ù̀l̀òm̀í̀j̀è̀]	[pà- ̀ǹz̀ù̀l̀òm̀í̀j̀è̀]	[nÁ- ̀ǹz̀ù̀l̀òm̀í̀j̀è̀]	/̀Ǹz̀ù̀l̀òm̀ -j̀È̀/	‘tongue’
[̀ǹz̀ù̀l̀òm̀á̀]	[pà- ̀ǹz̀ù̀l̀òm̀á̀]	[nÁ- ̀ǹz̀ù̀l̀òm̀á̀]	/̀Ǹz̀ù̀l̀òm̀ -á̀/	‘tongues’
[p̀ù̀d̀d̀d̀ì̀j̀é̀]	[pà- b̀ù̀d̀d̀d̀ì̀j̀é̀]	[nÁ- b̀ù̀d̀d̀d̀ì̀j̀é̀]	/b̀ù̀d̀d̀d̀ -j̀É̀/	‘pity’
[p̀ì̀j̀à̀l̀ó̀]	[pà- b̀ì̀j̀à̀l̀ó̀]	[nÁ- b̀ì̀j̀à̀l̀ó̀]	/b̀ì̀j̀à̀l̀ -Ú̀/	‘son’
[p̀ì̀j̀à̀l̀á̀à̀]	[pà- b̀ì̀j̀à̀l̀á̀à̀]	[nÁ- b̀ì̀j̀à̀l̀á̀à̀]	/b̀ì̀j̀à̀l̀ -á̀à̀/	‘sons’
[ǹè̀z̀è̀]	[pè- ǹè̀z̀è̀]	[né- ǹè̀z̀è̀]	/ǹè̀z̀è̀ -ø̀/	‘grandmother’
[ǹè̀z̀è̀ǹá̀à̀]	[pè- ǹè̀z̀è̀ǹá̀à̀]	[né- ǹè̀z̀è̀ǹá̀à̀]	/ǹè̀z̀è̀ -ǹá̀à̀/	‘grandmothers’
[è̀s̀í̀j̀è̀]	[pè- è̀s̀í̀j̀è̀]	[né- 'è̀s̀í̀j̀è̀]	/è̀s̀ -j̀È̀/	‘eye’
[è̀s̀á̀]	[pè- è̀s̀á̀]	[né- 'è̀s̀á̀]	/è̀s̀ -á̀/	‘eyes’

It is suggested that the nouns in (264) are specified for an underlying /L/ tone on their roots (/L/ roots). As in the previous case of /H/ roots, some of the nouns in (264) are suffixless, while other nouns have suffixes as shown in the fourth column, the tonal melodies of which have been determined as /H/, /HL/, and /LH/. It is argued that the fact that the surface tones on the roots are low, irrespective of the tone of the preceding prefixes and of the tones of the suffixes, is a clear indication that these roots carry also a /L/ tone underlyingly.

Another piece of evidence supporting the hypothesis of a /L/ tone on the roots in

(264) comes from the downstepped nouns of monomoraic roots, such as ‘eye’ and ‘eyes’, in the “after High tone” context shown in the third column. The singular and plural suffixes on the root for ‘eye’ are /H/ and /HL/, respectively. The addition of an H-toned prefix creates the HLH sequence that is a suitable environment for downstep, which is witnessed by ‘your eye’ and ‘your eyes’ in the third column, as expected. As seen, the underlying /L/ melody maps onto monosyllabic as well as polysyllabic roots. The single /L/ tone specified for the roots comes to be associated to the TBUs of the roots through spreading. The sample derivations of ‘pity’ and ‘eye’ are shown below.

Table 6.3 Derivation of the Singular Form for ‘pity’

Underlying form	L- LH bʊdɔd-jɛ	L- L - LH bA-bʊdɔd-jɛ	H- L - LH ɲA-bʊdɔd-jɛ
(Morpho)phonological change (<i>with Epenthetic Vowel insertion</i>)	L- LH bʊdɔd-i-jɛ	L-L -LH ba-bʊdɔd-i-jɛ	H-L -LH ɲa-bʊdɔd-i-jɛ
Initial association	L LH [bʊdɔdɪ] [jɛ]	L L LH [pa][bʊdɔdɪ][jɛ]	H L LH [ɲa][bʊdɔdɪ][jɛ]
Delinking (Contour simplification)	L LH bʊdɔdijɛ	L L LH pabʊdɔdijɛ	H L LH ɲabʊdɔdijɛ
Left-to-Right Spread (HTS & LTS)	L LH bʊdɔdijɛ	L L L H pabʊdɔdijɛ	H L L H ɲabʊdɔdijɛ
Merging (OCP repair) Surface forms	L H bʊdɔdijɛ	L H pabʊdɔdijɛ	H L H ɲabʊdɔdijɛ
Transcription	[pʊdɔdijɛ] ‘pity’	[pà-bʊdɔdijɛ] ‘their pity’	[ɲá-bʊdɔdijɛ] ‘your pity’

Table 6.4 Derivation of the Singular Form for ‘eye’

Underlying form	L-HL εs-jE	L-L-HL bE-εs-jE	H-L-HL ɲE-εs-jE
(Morpho)phonological change (with Epenthetic Vowel insertion)	L-HL εs-I-jε	L-L-HL bε-εs-I-jε	H-L-HL ɲε-εs-I-jε
Initial association	$\begin{array}{c} L \quad HL \\ \quad \diagdown \\ [\epsilon s I] \quad [j \epsilon] \end{array}$	$\begin{array}{c} L \quad L \quad HL \\ \quad \quad \diagdown \\ [p \epsilon] [\epsilon s I] [j \epsilon] \end{array}$	$\begin{array}{c} H \quad L \quad HL \\ \quad \quad \diagdown \\ [\eta \epsilon] [\epsilon s I] [j \epsilon] \end{array}$
Delinking (Contour simplification)	$\begin{array}{c} L \quad HL \\ \quad \diagdown \\ \epsilon s I j \epsilon \end{array}$	$\begin{array}{c} LL \quad HL \\ \quad \quad \diagdown \\ p \epsilon \epsilon s I j \epsilon \end{array}$	$\begin{array}{c} HL \quad HL \\ \quad \quad \diagdown \\ \eta \epsilon \epsilon s I j \epsilon \end{array}$
Merging (OCP repair)	NA	$\begin{array}{c} L \quad HL \\ \quad \\ p \epsilon \epsilon s I j \epsilon \end{array}$	NA
Vertical assimilation	NA	NA	$\begin{array}{c} HL \quad HL \\ \quad \quad \diagdown \\ \eta \epsilon \epsilon s I j \epsilon \end{array}$
Downstep	NA	NA	$\begin{array}{c} H \textcircled{L} HL \\ \quad \quad \diagdown \\ \eta \epsilon \epsilon s I j \epsilon \end{array}$
--- > Surface forms	$\begin{array}{c} L \quad HL \\ \quad \\ \epsilon s I j \epsilon \end{array}$	$\begin{array}{c} LL \quad HL \\ \quad \quad \\ p \epsilon \epsilon s I j \epsilon \end{array}$	$\begin{array}{c} H \textcircled{L} HL \\ \quad \quad \\ \eta \epsilon \epsilon s I j \epsilon \end{array}$
Transcription	[ɛ̀sɨ̀jɛ̀] ‘eye’	[pɛ̀-ɛ̀sɨ̀jɛ̀] ‘their eye’	[ɲɛ̀- ¹ ɛ̀sɨ̀jɛ̀] ‘your eye’

The tonal derivation of nouns of /L/ roots might allow tone spreading to be seen, because, there are often more TBUs on the segmental tier of the root than Ts in the

melody of polysyllabic roots. ‘Pity’, in Table 6.3, is an example of this case. It is the opposite for the monosyllabic suffixes, which have more Ts in the melody than morae to associate to on their segmental tier. Therefore, even for a polysyllabic root such as ‘pity’, tone initial association can still violate the ‘No contour constraint’, which triggers the Contour Tone Simplification. In Table 6.4, the derivation of the monosyllabic root noun ‘eye’, which ends up with two morae through an Epenthetic Vowel insertion for the single T of the root melody, is quite similar. But for the latter root, tone re-association through the Contour simplification leaves no T unassociated. Therefore, spreading is prevented from occurring. Identical tone sequence merging applies in the “After low” form of ‘their eye’ to also satisfy OCP, but in the “After high” form of ‘your eye’, it is downstep that applies, instead, following a vertical assimilation.

Despite the various processes in the derivation of nouns of /L/ roots and those of /H/ roots previously discussed, the surface tonal patterns exhibit no-to-little alteration, showing resistance to alteration, which indicates that these noun roots have underlying tone. This is unlike the third tone group of roots, which lack underlying tone.

6.3.2.3 Toneless Noun Roots (/T₀/ roots)

Other nouns exhibit two different surface tonal patterns in the three contexts considered. Characteristically, when these nouns occur in isolation, they carry a surface high tone on every mora of their roots. In included position, this tonal pattern is kept on the roots after an H-toned prefix, but all the surface tones on the morae of the roots change to low after an L-toned prefix. The tones of the suffixes, however, remain

unaltered. The nouns with such roots, which are illustrated by the forms in (265), represent the largest group in the language.

(265)

Isolation	After L tone	After H tone	Underlying	Gloss
Noun (N)	/bÀ/ ‘their’	/ɲÁ/ ‘your’	Noun Tones	
[tíú]	[pà- dìú]	[ɲá- díú]	/tɪ -Ú/	‘tree’
[tíŋ]	[pà- díŋ]	[ɲá- díŋ]	/tɪ -`N/	‘trees’
[mílím]	[pà- mìlím]	[ɲá- mílím]	/mɪl -´m/	‘theft’
[hábjé]	[pà- hàbjé]	[ɲá- hábjé]	/hab -jÉ/	‘road’
[há bá]	[pà- hà bá]	[ɲá- háb-á]	/hab -á/	‘roads’
[tós náù]	[pò- dòn náù]	[ɲó- dón náù]	/tɔɔna -´K/	‘food’
[tós ná sɪ]	[pò- dòn ná sɪ]	[ɲó- dón ná sɪ]	/tɔɔna -´sÌ/	‘foods’

The tonal behavior of the nouns in (265) indicates that their roots are underlyingly toneless (/T₀/ roots). The surface tones on the roots appear to alternate depending on the tonal environment in which the roots occur. The fact that the surface tones on root TBUs change with different environments is strong evidence for these roots bearing no underlying melody even though their surface forms bear tone. The tones on the root TBUs are high after an H-toned prefix and change to low after an L-toned prefix, suggesting that these underlyingly toneless roots receive their surface tones through spreading from the prefix that precedes them. Hence after an H-toned prefix, the TBUs of the roots receive high tones, and after an L-toned prefix, the TBUs of the roots receive low tones. The suffixes found on these roots, on the other hand, are specified for lexical tones, the tonal melodies of which are determined in the fourth column as /H/ and /HL/. It is further argued that in the absence of a prefix, as attested

by the nouns occurring in “Isolation” in the first column, the TBUs of the /T₀/ roots receive surface tone from the suffix through suffix tone spreading, which occurs later in the derivation. The best indication that the roots of these nouns have no lexical tone comes from the “After L tone” forms (2nd column), which exhibit the change in tone only on the morae of the roots but not on those of the suffixes.

The application of the tone association conventions and rules specified earlier account for the surface realizations of the nouns in (265). The derivation of the singular noun of ‘food’ is shown.

Table 6.5 Derivation of the Singular Form for ‘food’

Underlying form	∅-HL tɔɔna-K	L-∅-HL bɔ-tɔɔna-K	H-∅-H L ɲɔ-tɔɔna-K
(Morpho)phonological change	HL tɔɔnaɔ	L - HL pɔɔɔɔnaɔ	H -HL ɲɔɔɔɔnaɔ
Initial association	HL [tɔɔna][a]	L HL [pɔ][dɔɔna][a]	H HL [ɲɔ][dɔɔna][a]
Delinking (Contour simplification)	HL ≠ tɔɔnaɔ	L HL pɔɔɔɔna a	H HL ɲɔ dɔɔnaɔ
Left-to-Right Spread (HTS & LTS)	NA	L HL pɔɔɔɔna a	H HL ɲɔɔɔɔnaɔ
Right-to-Left Spread (HTS & LTS)	HL tɔɔnaɔ	NA	NA

Table 6.5 *Continued*

Merging (OCP repair)	NA	NA	
---> Surface forms			
Transcription	[tɔ́ɔ́nǎ̀] ‘food’	[ɲɔ̀-dɔ́ɔ́nǎ̀] ‘their food’	[ɲɔ̀-dɔ́ɔ́nǎ̀] ‘your food’

For the derivation in Table 6.5, the initial association of the Ts of the melody to the TBUs of the morphemes, leaves the TBUs in the toneless root ‘food’ unassociated. Therefore, the Left-to-Right Spread, which occurs after to tone re-association through Contour simplification on the suffix, spreads the prefix tone to the remaining unassociated Ts of the root. The toneless root of the noun receives tone from the suffix through the subsequent Right-to-Left Spread, only if the noun has no prefix. If it has a prefix, then this second spreading is prevented, since Ts are already associated. The initial association, which associated the Ts in the melody to the TBUs in the segmental tier of the morpheme, thereby, leaving the TBUs of the root unassociated, is responsible for these TBUs need tone from their surrounding for their surface realization.

6.3.2.4 High-Low Melody Noun Roots (/HL/ roots)

The surface tonal pattern of the roots in the nouns of the fourth tone group begins as high followed by low. It may also begin with H followed by downstep. But the tonal pattern on the roots of the nouns remains consistent in all three contexts. Consider the nouns in (266).

(266)

Isolation	After L tone	After H tone	Underlying	Gloss
Noun (N)	/bÀ/ ‘their’	/ɲÁ/ ‘your’	Noun Tones	
[só'móɾé]	[pò- zó'móɾé]	[ɲó- zó'móɾé]	/sómòl -dÉ/	‘papaya’
[só'mólá]	[pò- zó'mólá]	[ɲó- zó'mólá]	/sómòl -á/	‘papayas’
[séjì]	[pè- zéjì]	[ɲé- zéjì]	/séj̃- ø/	‘grandchild’
[sé'jínáà]	[pè- zé'jínáà]	[ɲé- zé'jínáà]	/séj̃- náà/	‘grandchildren’
[tákàjàú]	[pà- dákàjàú]	[ɲá- dákàjàú]	/tákàj -àK/	‘book’
[tá'kájísì]	[pà- dá'kájísì]	[ɲá- dá'kájísì]	/tákàj -'sÌ/	‘books’

The same reasoning as for the previous roots discussed leads to the suggestion that the roots in (265) carry an underlying /HL/ melody (/HL/ roots). The consistency of the surface tonal pattern on the roots as high followed by low in the contexts considered allows us to hypothesize that these roots carry underlying /HL/ melody. Similar to the previous /L/ roots seen in §6.3.2.2, the surface pattern of many of the /HL/ root nouns often exhibit downstep, which strongly testifies to the underlying L that follows the H in the melody of these roots. It is argued that downstep also happens in the /HL/ roots when the environment of /HLH/ sequence is created by affixation. The suffixes associated with these roots also have underlying tones, which are shown as /H/, /HL/, and /LH/ in the fourth column. The form of ‘grandchildren’ occurring “in isolation,” which takes only the suffix yet is downstepped, is the best illustration of the case. If the roots of these nouns had only /H/ underlyingly, their surface patterns would not be expected to exhibit downstep in these contexts.

Table 6.6 Derivation of the singular Form for ‘papaya’

Underlying form	HL H somol-ɔ̄e	L HL H bo-somol-ɔ̄e	H HL H no-somol-ɔ̄e
(Morpho)phonological changes (w. <i>Consonant Cluster Simplification</i>)	HL H [somo][ɾe]	L HL H [bozomo][ɾe]	H HL H [no][zomo][ɾe]
Initial association	$\begin{array}{c} H \quad L \quad H \\ \quad \quad \\ [somo][ɾe] \end{array}$	$\begin{array}{c} L \quad H \quad L \quad H \\ \quad \quad \quad \\ [bo][zomo][ɾe] \end{array}$	$\begin{array}{c} H \quad H \quad L \quad H \\ \quad \quad \quad \\ [no][zomo][ɾe] \end{array}$
Merging (OCP repair)	NA	NA	$\begin{array}{c} H \quad L \quad H \\ \diagdown \quad \quad / \\ nozomoɾe \end{array}$
Vertical assimilation	$\begin{array}{c} H \quad L \quad H \\ \quad \neq \quad / \\ somoɾe \end{array}$	$\begin{array}{c} L \quad H \quad L \quad H \\ \quad \quad \neq \quad / \\ bozomoɾe \end{array}$	$\begin{array}{c} H \quad L \quad H \\ \diagdown \quad \neq \quad / \\ nozomoɾe \end{array}$
Tone re-linking (downstep) ---> Surface forms	$\begin{array}{c} H \quad \textcircled{L} \quad H \\ \quad \diagup \\ somoɾe \end{array}$	$\begin{array}{c} L \quad H \quad \textcircled{L} \quad H \\ \quad \quad \diagup \\ bozomoɾe \end{array}$	$\begin{array}{c} H \quad \textcircled{L} \quad H \\ \diagdown \quad \diagup \\ nozomoɾe \end{array}$
Transcription	[só'móɾé] ‘papaya’	[pò-zó'móɾé] ‘their papaya’	[nó-zó'móɾé] ‘your papaya’

Table 6.7 Derivation of the plural Form for ‘grandchildren’

Underlying form	HL - HL sej-naa	L-HL-HL bE-sej-naa	H-HL-HL nE-sej-naa
(Morpho)phonological changes (with <i>Epenthetic Vowel insertion</i>)	HL - HL [sej-ɪ][naa]	L-HL- HL [bɛ][zɛj-ɪ][naa]	H-HL- HL [nɛ][sej-ɪ][naa]
Initial association	$\begin{array}{c} HL- \quad HL \\ \quad \quad \quad \\ [sejɪ][naa] \end{array}$	$\begin{array}{c} L - HL- HL \\ \quad \quad \quad \\ [bɛ][zɛjɪ][naa] \end{array}$	$\begin{array}{c} H - HL- HL \\ \quad \quad \quad \\ [nɛ][sejɪ][naa] \end{array}$

Table 6.7 *Continued*

Merging (OCP repair)	N/A	N/A	$\begin{array}{c} \text{H} \quad \text{LHL} \\ \diagdown \quad \diagup \quad \quad \\ \text{ɲɛzɛjɪnaa} \end{array}$
Vertical assimilation	$\begin{array}{c} \text{HL} \quad \text{HL} \\ \quad \quad \quad \\ \text{sejɪnaa} \end{array}$	$\begin{array}{c} \text{LHL} \quad \text{HL} \\ \quad \quad \quad \\ \text{pɛzɛjɪnaa} \end{array}$	$\begin{array}{c} \text{H} \quad \text{LHL} \\ \diagdown \quad \diagup \quad \quad \\ \text{ɲɛzɛjɪnaa} \end{array}$
Tone re- association (downstep) ---> Surface forms	$\begin{array}{c} \text{H} \textcircled{\text{L}} \text{HL} \\ \quad \quad \quad \\ \text{sejɪnaa} \end{array}$	$\begin{array}{c} \text{L} \text{H} \textcircled{\text{L}} \text{HL} \\ \quad \quad \quad \\ \text{pɛzɛjɪnaa} \end{array}$	$\begin{array}{c} \text{H} \textcircled{\text{L}} \quad \text{HL} \\ \diagdown \quad \diagup \quad \quad \\ \text{ɲɛzɛjɪnaa} \end{array}$
Transcription	[sɛ́jɪnáà] 'grandchildren'	[pɛ̀- zɛ́jɪnáà] 'their grandchildren'	[ɲɛ́-zɛ́jɪnáà] 'your grandchildren'

The Derivations of the /HL/ root nouns in Table 6.6 and Table 6.7 are straightforward. There is a same number of Ts as TBUs in the morphemes of both nouns after the epenthetic vowel insertion in 'grandchildren', so, initial association provides all the TBUs with Ts and all the Ts are associated. Therefore, tone spreading is prevented. But, as often, OCP repair applies. It is followed by a vertical assimilation and downstep in both forms. It is noted that tone spreading is mostly seen in their derivations. Tone spreading from the prefix is prevented in roots with underlying melodies by the well-formedness condition, because initial association links the left edge of the roots.

6.3.2.5 Low-High melody Noun Roots (/LH/ roots)

The fifth tone group of nouns roots includes nouns with a surface tonal pattern that begins low, then changes to high. After an H-toned prefix, an L-toned prefix, or in isolation, the tonal pattern is very much the same. Like in the case of the other nouns

described, the only small change that can be observed in the nouns of the this tone group, is downstep, which does not happen in the forms occurring in isolation nor in the “after L-tone” forms, but they occur quite freely in the forms that occur after the H-toned prefix, as illustrated in (267).

(267)

Isolation	After L tone	After H tone	Underlying	Gloss
Noun (N)	/bÁ/ ‘their’	/ɲÁ/ ‘your’	Noun Tones	
[sɔɔjɛ̀]	[pɔ̀- zɔɔjɛ̀]	[ɲɔ̀- ʔsɔɔjɛ̀]	/sɔɔj -È/	‘mortar’
[sɔɔ]	[pɔ̀- zɔɔ]	[ɲɔ̀- ʔsɔɔ]	/sɔɔj -ø/	‘mortars’
[ègbélè]	[pɛ̀- ègbélè]	[ɲé- ʔégbélè]	/ègbélè -È/	‘maternal uncle’
[ègbénaà]	[pɛ̀- ègbénaà]	[ɲé- ʔégbénaà]	/ègbélè -náà/	‘maternal uncles’
[èsɔ]	[pɛ̀- èsɔ]	[ɲé- ʔésɔ]	/èsɔ -ø/	‘God’
[èsónáà]	[pɛ̀- èsónáà]	[ɲé- ʔésɔ-náà]	/èsɔ -náà/	‘gods’

Following the same line of reasoning as for the nouns presented earlier, it is argued that the nouns in (267) carry underlying /LH/ melody on the roots (/LH/ roots). The underlying tones of the suffixes on these nouns are determined as /L/ and /HL/ except the form of ‘mortars’, which takes no suffix. The downstep, observed in the “After H tone” forms, also evidences the L at the initial of the melody of these /LH/ roots. A sample derivation of /LH/ root nouns is shown for ‘mortar’.

Table 6.8 Derivation of the Singular Form for ‘mortar’

Underlying form	LH L sɔɔ-jɛ̀	L -LH -L bO-sɔɔ-jɛ̀	H -LH -L ɲO-sɔɔ-jɛ̀
(Morpho)phonological changes	LH L sɔɔ-jɛ̀	L -LH -L bɔ-zɔɔ-jɛ̀	H -LH -L ɲɔ-zɔɔ-jɛ̀
Initial association	$\begin{array}{c} \text{LH} \quad \text{L} \\ \quad \quad \\ [\text{s}\text{ɔ}\text{ɔ}] [\text{j}\text{ɛ̀}] \end{array}$	$\begin{array}{c} \text{L} \quad \text{LH} \quad \text{L} \\ \quad \quad \\ [\text{b}\text{ɔ}] [\text{z}\text{ɔ}\text{ɔ}] [\text{j}\text{ɛ̀}] \end{array}$	$\begin{array}{c} \text{H} \quad \text{LH} \quad \text{L} \\ \quad \quad \\ [\text{ɲ}\text{ɔ}] [\text{z}\text{ɔ}\text{ɔ}] [\text{j}\text{ɛ̀}] \end{array}$

Table 6.8 *Continued*

Merging (OCP repair)	N/A	$\begin{array}{c} L \quad H \quad L \\ \diagdown \quad \quad \\ b \quad \text{ɔ} \quad z \quad \text{ɔ} \quad \text{ɔ} \quad j \quad \epsilon \end{array}$	N/A
Vertical assimilation	N/A	N/A	$\begin{array}{c} H \quad LH \quad L \\ \quad \neq \quad \quad \\ \text{ɲ} \quad \text{ɔ} \quad z \quad \text{ɔ} \quad \text{ɔ} \quad j \quad \epsilon \end{array}$
Tone re-association (downstep)	N/A	N/A	$\begin{array}{c} H \textcircled{1} \quad H \quad L \\ \quad \diagdown \quad \quad \\ \text{ɲ} \quad \text{ɔ} \quad z \quad \text{ɔ} \quad \text{ɔ} \quad j \quad \epsilon \end{array}$
---> Surface forms	$\begin{array}{c} LH \quad L \\ \quad \quad \\ s \quad \text{ɔ} \quad \text{ɔ} \quad j \quad \epsilon \end{array}$	$\begin{array}{c} L \quad LHL \\ \quad \quad \quad \quad \\ b \quad \text{ɔ} \quad z \quad \text{ɔ} \quad \text{ɔ} \quad j \quad \epsilon \end{array}$	$\begin{array}{c} H \textcircled{1} \quad H \quad L \\ \quad \diagdown \quad \quad \\ \text{ɲ} \quad \text{ɔ} \quad z \quad \text{ɔ} \quad \text{ɔ} \quad j \quad \epsilon \end{array}$
Transcription	[sɔɔjɛ] 'mortar'	[pɔ-zɔɔjɛ] 'their mortar'	[ɲɔ-'zɔɔjɛ] 'your mortar'

Downstep caused by the vertical assimilation is the most remarkable step in the tonal derivation of 'mortar' in Table 6.8. The Ts are fairly well associated to TBUs, except for the OCP violation, which is repaired by merging sequences of identical tones. As seen, association of the suffix tones does not cause downstep, but it is the preceding H of the prefix that creates the environment for this phenomenon to happen in /LH/ roots.

Underlying /LH/ melody maps only onto polymoraic roots, some of which may also be monosyllabic as exemplified by 'mortar'. In the derivation of this noun, it is also observed that the second mora (of the long vowel occurring in root-final position) is not shortened before the suffix. It is likely that this happens because that second mora is needed to carry the second tone in the root melody. Tone association, therefore, tends to preserve the segmental form of the morpheme.

6.3.2.6 Tonal melodies of noun prefixes and suffixes

As seen throughout the illustrations of nouns, the prefixes and suffixes that attach to noun roots also carry underlying melodies.

There is a variety of suffixes found on nouns, which carry similar melodies as the roots, only two melodies are found on noun prefixes. The melodies of the prefixes are usually straightforward and determined as /L/ and /H/. The underlying tonal melodies of the suffixes are determined as /L/, /H/, /HL/, /LH/. These melodies are exactly the same as the ones occurring on the roots, except that unlike the roots, we found no /T₀/ melody on the suffixes. The melodies of the prefixes easily co-occur with all five root melodies, but that is not always the case for the melodies of the suffixes.

Table 6.9 Inventory of Noun Suffixes and their Tonal Melodies

Tonal melodies of noun roots	Tonal melodies of noun suffixes				
	∅ ⁵³	/H/	/L/	/HL/	/LH/
/T ₀ / roots		-Ú, -jÉ, -á, -K, -É, -ká		-'N, -'m, -'K, -'sì, -'Ù, -'à, -'jÈ, -'qÈ, -'È, -àà	-'lá
/H/ roots	-∅	-jÉ	-Ù, -jÈ	-'N, -náà, -Ù	
/L/ roots	-∅	-á, -Ú, -É, -m, -N, -qÉ, -ká, -K	-qjE/-qÈ, -à, -È, -ljE, -ÙU, -kÙ, -kÚ	-'jÈ, -àà, -náà, -'m, -'N, -àà, -'sì, -'qÈ	-jÉ, -'jÈ
/HL/ roots	-∅	-qÉ, -á, -ná, -jÉ, -wé, -jÉ, -K		-náà, -'sì, -ásì	-àK -jÈÉ
/LH/ roots	-∅	-á	-jÈ, -ljE, -à, -È, -kàK	-'tÙ, -náà, -'sì, -àà, -'m	

⁵³ A zero suffix with zero tone

Table 6.9 summarizes the underlying tonal melodies of nominal suffixes and also shows the corresponding root melodies with which they co-occur. It is seen that the /H/ suffix melody tends to map only onto mono-moraic syllables while the /L/ suffix melody can map onto mono-moraic as well as bi-moraic syllables. The /HL/ and /LH/ suffix melodies also map onto mono-moraic as well as bi-moraic syllables.

With respect to a correlation between suffix melodies and root melodies, it can be noticed that all the melodies of the suffixes tend to co-occur with any of the root melodies, however, with only a few exceptions. For instance, /L/ suffixes do not co-occur with /T₀/ roots and HL/ roots, /LH/ suffixes do not co-occur with /H/ roots and /LH/ roots. This is seen in the empty slots under these suffix melodies, which correspond to the root melodies in Table 6.9. While this could be coincidental (due to a lack of such instances in the data collected, for example), what is *also* seen in Table 6.9 that might not be coincidental is that all the roots can also be suffixless (i.e., both segmentally and tonally) except the /T₀/ roots, which must have a suffix. This may be critical: since prefixes are optional in the noun, the nominal root must receive tone from the surrounding context, i.e., the suffix in the absence of the prefix.

The nouns of Kabiye have thus been shown to fall under five groups, based on the underlying tonal melody of their roots. There are nouns with toneless roots (/T₀/ roots), and nouns of four tonal melody roots, /H/, /L/, /HL/ roots, and /LH/. The singular and plural forms of nouns of the five groups of roots usually take suffixes that carry identical underlying tonal melodies. However, a /T₀/ root requires a suffix, on which it

must depend for surface tones. Like suffixes, prefixes must always have underlying tone, the melodies of which are only /H/ and /L/. In the process of noun formation, an association of the Ts in the underlying melodies of the roots and affixes to the TBUs on the segmental tier of their sponsoring morphemes, following specific rules allowed by the language ensures that all the TBUs within the noun are associated to tone.

Kabiye makes use of various tone mapping rules to give surface tone to all the TBUs in the noun and ensure that Ts are properly associated to TBUs. In this process, however, the derivation rules and principles must apply in a specific order. It also appears that while noun roots seldom carry more tones on the tonal tier than the underlying TBUs on the segmental tier, many suffixes have more underlying tones in their tonal melody tier than TBUs on the segmental tier of their sponsoring roots, unlike in the prefixes, which are monosyllabic and monotonic. Therefore, initial tone association in the suffix often causes linking of multiple Ts to a TBU, in frequent violation of the no-contour constraint. Consequently, a contour simplification follows to delink the last associated of the multiply associated Ts and relinks to the available TBU of the root next to it (i.e., the TBU in root-final position or the epenthetic vowel that is often inserted between the root and the suffix to split consonant clusters). OCP repair strategies apply to merge sequences of identical underlying tones. Vertical assimilation or register lowering followed by downstep, also occurs in /HLH/ sequences, where the L is singly linked. There are often less Ts in the melodies of polysyllabic roots than TBUs on the segmental tier of the root, allowing tone spreading to occur in the

derivation of nouns. It is usually the opposite for the suffixes which often have more Ts than segmental TBUs. While tone association in the morphemes occurs only left to right, tone spreading, on the other hand, happens left to right and right to left.

Tone spreading is not automatic in Kabiye and occurs at two levels in the derivation following different directionalities. The first spreading occurs left to right (Left-to-Right Spreading) in the word, following the initial association and after Contour Tone Simplification has applied to re-association tone properly. The second spreading, which occurs as Right-to-Left Spreading, follows immediately to provide tone to any TBU that the first spreading might have left still unassociated. Both of the distinctive tones, /H/ and /L/ can spread. Kabiye therefore has H Tone Spreading (HTS) and L Tone Spreading (LTS), both of which can occur at the two levels of tone spreading. This is necessary because the first spreading, which applies left-to-right, can be prevented from actually occurring, hence leaving unassociated the TBUs of a toneless root that has no prefix. These TBUs must receive tone from the suffix, then, through another round of spreading, which can only happen from right-to-left. The Left-to-Right Spreading (1st spreading), therefore, is the main spreading; the Right-to-Left Spreading (2nd spreading) happens as a default spreading. Tone spreading is also prevented if the association has linked all the TBUs to T. Therefore, the left-to-right tone spreading from the prefix and the right-to-left tone spreading from the suffix in nouns of toneless roots are responsible for the roots of these nouns carrying different surface tonal patterns in different environments.

6.3.3 Tonal Melodies of Verb Roots

Determining the underlying tonal melodies of Kabiye verbs is a more complicated issue than nouns because verbs often occur in inflected forms (including the Infinitive), morphologically and tonally, for tense, aspect and mood. Therefore, it is difficult to determine if one of the forms represents the underlying form. In Roberts 2002, the melodies of the Imperative forms were equated to the underlying melodies of verb roots. However, under the current research, the Imperative forms appeared to be inflected. For instance, a tonal variation is observed in the roots between the Imperative forms [tìì] 'descend!' or [wòlò] 'go!', and their Infinitive forms [tíbù] and [wóbù], respectively. Based only on the morphological difference in the Imperative and the Infinitive forms of these verbs, the current study started on the assumption that the Imperative forms are inflected morphologically, and probably tonally as well, since the tones in both forms of each verb are also different. It was therefore important to find a more adequate way to determine the underlying tonal melodies of verb roots.

Substitution frames were used instead, which allow us to determine the underlying tonal melodies on verb roots. After examination of the tones of verb roots in these environments, five tone groups of verb roots were posited. The underlying tonal melodies of verb roots are determined following the same interpretation of the Autosegmental theory. However, it will not be necessary to show derivations for the verb forms presented in this section. Since the forms are nominal or take noun suffixes, the derivation of nouns shown earlier will also serve as illustration for the derivation of

the formation of deverbal substantives and deverbal adjectives presented in this section, which are derived as a result of the specific frames used. It is also noted that the suffixes occurring on the verb roots in the frames used are among the noun suffixes that have just been examined and described.

6.3.3.1 High Melody Verb Roots (/H/ Roots)

Within the frames used for the analysis of the tonal melodies of verb roots (specified in the methodology section), it is observed that some verb roots will occur with H tone on the root. The examples (268), (269), and (270) illustrate verb roots of deverbal adjectives and deverbal substantives occurring in after the H-toned adjective formation prefix illustrated by a. forms and after the L-toned deverbal substantives formation prefix, which is illustrated by b. forms. In both contexts, the tones of the suffixes on the forms are low.

(268)

- | | | | | |
|----|-------|-------|--------|--------------------------|
| a. | /kí- | kpá | -wù/ | [kíkápáwù] ‘climbed’ |
| | Adjr- | climb | -3SgT2 | |
| b. | /tì- | kpá | -jè/ | [tìgbájè] ‘the climbing’ |
| | Pref- | climb | -5SgT3 | |

(269)

- | | | | | |
|----|-------|-----|--------|--|
| a. | /kí- | sé | -jù/ | [kíséjù] ‘the run away (one)’ |
| | Adjr- | run | -1SgT1 | |
| b. | /dì- | sé | -jè/ | [tìzèjè] ‘the process of running away’ |
| | Pref- | run | -5SgT3 | |

(270)

- | | | | | |
|----|-------|------|--------|------------------|
| a. | /kí- | há | -jù/ | [kíhájù] ‘given’ |
| | Adjr- | give | -1SgT1 | |

b.	/dǐ-	há	-jÈ/	[tǐhájè] ‘the giving’
	Pref-	give	-5SgT3	

These verb roots are determined as underlying /H/ melody roots (/H/ Roots). The tone on the suffixes is the same. Since the tone on the verb roots is high after both the H-toned prefix and the L-toned prefix, it is interpreted that they also carry a /H/ in their lexical melody.

6.3.3.2 Low Melody Verb Roots (/L/ Roots)

The verb roots occurring in the forms appearing in (271) through (274) exhibit the following surface tonal patterns. After the H-toned prefix in the (a) forms, the roots might surface with H tone (as in (272)a, (273)a, and (274)a, or with a downstep (as in (271)a and (272)c). After the L-toned prefix, in (271)b, (272)b, (273)b, and (274)b, the tone on the verb root is always low.

(271)

a.	/kǐ-	lèm	-á/	[kǐ'lémá] ‘dried’
	Adjr-	dry	-6PIT3	
b.	/dǐ-	lèm	-dÉ/	[tǐlèné] ‘place for drying’
	Pref-	dry	-5SgT3	

(272)

a.	/kǐ-	lèb	-àK/	[kǐlèbàú] ‘lost (one)’
	Adjr-	lose	-7SgT4	
b.	/dǐ-	lèb	-jÉ/	[tǐlèbìjé] ‘the process of losing’
	Pref-	lose	-5SgT3	
c.	/kǐ-	lèb	-ásÌ/	[kǐ'lébásì] ‘lost (ones)’
	Adjr-	lose	-8PIT4	

(273)

- a. /kÍ- tìz -ɪ -wÚ/ [kítìzìwú] ‘cooked’
 Adjr- cook -EpV -3SgT2
- b. /dǐ- tìz -ɪ -jÉ/ [tìdìzìjé] ‘cooking place’
 Pref- cook -EpV -5SgT3

(274)

- a. /kÍ- sùlum -ɪ -wÚ/ [kúsùlùmìwú] ‘borrowed’
 Adjr- ask for -EpV -3SgT2
- b. /dǐ- sùlum -ɪ -jÈ/ [tìzùlùmìjé] ‘the asking for’
 Pref- ask for -EpV -5SgT3

It is suggested for the group of verb roots illustrated by (271) through (274) that they carry an underlying /L/ tone (/L/ roots). After the L-toned prefix illustrated by the b. forms, the root /L/ always surfaces also as low. However, more critical is the fact that after the H-toned prefix, the roots can carry L tone, too. Furthermore, they sometimes show downstep, too. It is further argued that this phenomenon happens when the suffix attached to these /L/ roots carries a /H/ tone like the prefix, thus creating the HLH sequence where the /L/ is associated to the single TBU of the root, which causes tonal downstep, as seen earlier with the noun roots. The downstep that occur in these specific forms further confirms the existence of a /L/ on the roots.

6.3.3.3 High-Low Melody Verb Roots (/HL/ Roots)

The verb roots of this tone group always carry surface high-low tones after the H-toned adjectival prefix and after the L-toned nominal prefix as shown in (275) to (278).

(275)

- a. /kÍ- súz -ì -wÙ/ [kúsúziwù] ‘publicized’
 Adjr- publicize -EpV -1SgT1

b. /dǐ̀- súz -ì -jÈ/ [tʰisúzìjè] ‘publicizing’
 Pref- publicize -EpV -5SgT3

(276)

a. /kí- séz -ì -jÙ/ [kísézìjù] ‘reaching one’
 Adj- reach -EpV -1SgT1

b. /dǐ̀- séz -ì -jÈ/ [tʰézèjè] ‘the reaching’
 Pref- reach -EpV -5SgT3

(277)

a. /kí- kól -ì -jàa/ [kókólìjàà] ‘exorcized ones’
 Adj- exorcize -EpV -2PIT1

b. /dǐ̀- kól -ì -jÈ/ [tʰgólìjè] ‘delivering from a spirit’
 Pref- exorcize -EpV -5SgT3

(278)

a. /kí- múz -ì -jàa/ [kúmúzìjàà] ‘groaning’
 Adj- groan -EpV -2PIT1

b. /dǐ̀- múz -ì -jÈ/ [tʰímúzìjè] ‘the groaning’
 Pref- groan -EpV -5SgT3

For the group of verb roots illustrated by (275) through (278), it is suggested that they carry underlying /HL/ melody (/HL/ roots). After the high-toned prefix in the (a) forms and after the L-toned prefix in the b. forms, the melody of the roots always surface as high-low, which is an indication that they also carry /HL/ tones, underlying. The data collected in this study did not contain any /HL/ roots with a /H/ tone suffix, but it can be hypothesized that the substantives derived from these verb roots would also often exhibit downstep if H-toned suffixes were attached to them.

6.3.3.4 Low-High Melody Verb Roots (/LH/ roots)

Examples of the fourth tone group of verb roots are found in the adjectives and substantives illustrated in (279) and (280). These roots exhibit two surface tonal patterns. The roots show low-high pattern after the L-toned prefix. After the H-toned prefix, the root tones always surface with downstep phenomenon.

(279)

- | | | | | | |
|----|-------|-----------|------|--------|------------------------------|
| a. | /kí- | tʃèl | -í | -jù/ | [kí'tʃéíjù] 'handed over' |
| | Adjr- | hand^over | -EpV | -1SgT1 | |
| b. | /qì- | tʃèl | -í | -jÉ/ | [tʃèlìjè] 'the handing over' |
| | Pref- | hand^over | -EpV | -5SgT3 | |

(280)

- | | | | | | |
|----|-------|-----|------|--------|------------------------|
| a. | /kí- | sìd | -í | -'tù/ | [kí'sídítù] 'mixed' |
| | Adjr- | mix | -EpV | -9T5 | |
| b. | /qì- | sìd | -í | -jÈ/ | [tʃìdìjè] 'the mixing' |
| | Pref- | mix | -EpV | -5SgT3 | |

The underlying tonal melody of the roots shown in (279) and (280) is determined as /LH/ (/LH/ roots). In the b. examples after the L-toned prefix, this melody also surfaces unaltered. But after the H-toned prefix, the /HLH/ sequence that are suitable for downstep are created. This phenomenon does happen systematically in the forms of the roots that occur after the H-toned prefix, confirming the lexical melody of these roots as a sequence of /LH/.

6.3.3.5 Low-High-Low Melody Verb Roots (/LHL/ Roots)

The verb roots in this tonal group always surface with a low-high-low pattern after the L-toned prefix, and always with downstep after the H-toned prefix. But unlike the /LH/ verb roots and some of the /L/ verb roots seen earlier, the roots of this tonal group also carry an L tone on their final mora, after the downstepped tones. The data in (281), (282), and (283) illustrate these roots.

(281)

- | | | | | | | |
|----|-------|-------|------|--------|---------------|-----------|
| a. | /kí- | hòlós | -ì | -wù/ | [kí'hólósìwù] | 'sipping' |
| | Adjr- | sip | -EpV | -3SgT2 | | |
| b. | /dì- | hòlós | -ì | -jÈ/ | [tìhòlósìjè] | 'sipping' |
| | Pref- | sip | -EpV | -5SgT3 | | |

(282)

- | | | | | | | |
|----|-------|---------|------|--------|--------------|--------------|
| a. | /kí- | tʃòlís | -ì | -àK/ | [kí'ʒólísàà] | 'sharpened' |
| | Adjr- | sharpen | -EpV | -7SgT4 | | |
| b. | /dì- | tʃòlís | -ì | -jÈ/ | [tìʒòlísìjè] | 'sharpening' |
| | Pref- | sharpen | -EpV | -5SgT3 | | |

(283)

- | | | | | | | |
|----|-------|---|------|--------|--------------|----------------------------|
| a. | /kí- | hòól | -ì | -jÈ/ | [kú'hóólìjè] | 'carried on shoulder' |
| | Adjr- | carry [^] on [^] shoulder | -EpV | -5SgT3 | | |
| b. | /dì- | hòól | -ì | -jÈ/ | [tìhòólìjè] | 'the carrying on shoulder' |
| | Pref- | carry [^] on [^] shoulder | -EpV | -5SgT3 | | |

The roots in the tonal group illustrated by these verb roots appear to carry an underlying /LHL/ melody (/LHL/ roots). Similar to other roots that have been discussed, the roots in this group will also surface with their underlying melody pattern when the roots appear after the L-toned prefix ((281)b, (282)b, and (283)b). The surface

downstepped forms ((281)a, (282)a, and (283)a) are also explained as triggered by the underlying /HLH/ sequence created by the H-tone prefix.

A general thing to point out about verb roots is most verb roots receive the epenthetic vowel before the suffix. It is further noticed that this vowel insertion happens very frequently with polytonic melody roots, but rarely with the monotonic melody roots. Unlike the case of nouns, this vowel is usually associated to the root melody tone. This implies that verb roots often have more Ts in their melodies than the morae they these Ts associated to in the segmental tier of the morphemes. Therefore, epenthetic vowel, which serves to split consonants clusters caused by the suffixation is also needed for the purpose of carrying the final tone of the verb root melody.

As shown in this section, verb roots are underlyingly specified for tonal melodies according to which these roots can be grouped into five as /H/ roots, /L/ roots, /HL/ roots, /LH/ roots, and /LHL/ roots. Often, the melodies will surface with the same tonal patterns after the L-toned prefix *dʒi-* in the formation of location deverbal substantives (or relational locatives) and after the H-toned adjectival prefix *kɪ-* in the formation of deverbal adjectives. However, when these affixes create sequences of /HLH/, the underlying melodies of verb roots surface with a slightly altered tonal pattern to show downstep phenomenon, which is the only tonal alteration observed in these roots.

6.4 Conclusion

This chapter has provided a phonetic and phonological description of Kabiye tone manifested in the word. The phonetic aspect of the study, which has shown some aspects of the acoustic nature of tone, examined pitch tracks and F_0 measurements and indicated that acoustically, the high tone and the low tone manifest themselves differently. The pitch tracks of a high tone, whether on a short vowel ([H]) or a long vowel ([HH]) shows an upward movement whereas the pitch tracks of a low tone on a short vowel ([L]) or a long vowel ([LL]) shows a downward movement. But the slope of the tracks of the low tone is bigger than the one of the high tone, a difference that is translated into the F_0 values of both tones. Hence, a high tone originates at a certain frequency and ends at a higher frequency whereas a low tone originates at a certain frequency and ends at a lower frequency. But in general, the beginning F_0 of a high tone is higher than the beginning F_0 of a low tone, though some overlap of the frequency range of the high tones and the frequency range of the low tones occurs at times. In the case of Kabiye, the F_0 variation of the high and low tones was also influenced by the unusual projected voice of the subjects, which caused the F_0 values to be higher than normal.

The phonological aspect of the study has investigated the surface tones of words, endeavoring to determine the underlying tones, both the distinctive tones of the language and the tonal melodies specified underlyingly on the basic component morphemes of the word, which are roots and affixes. Therefore, tones of noun roots and

nominal suffixes have been analyzed in nouns uttered in isolation, after an H-toned representative prefix, and after an L-toned representative prefix. Verb roots have also been examined within similar contexts, specifically after an H-toned prefix in deverbal adjectives and after an L-toned prefix in the location deverbal substantives also known as relational locatives. The analysis determined four underlying tonal melodies on five groups of noun roots, with one group of nouns including toneless roots (/T₀/ roots). The other four groups of roots with tonal melodies are /H/ roots, /L/ roots, /HL/ roots, and /LH/ roots. The tonal melodies of the suffixes found on these roots in the nouns were also determined as /H/, /L/, /HL/, and /LH/. No toneless noun suffixes are found. The tonal melodies of the prefixes are only /H/ and /L/. The underlying melodies of noun roots have been found to often map onto morphemes with equal or lesser number of TBUs as the Ts in the melody. The melodies of noun suffixes map onto morphemes of with equal but often greater number of TBUs as the Ts in the melody; rarely does a suffix melody map onto a segmental morpheme with more TBUs than the Ts in its tonal melody. In the association of Ts to TBUs following a specific set of Autosegmental theory rules, during word formation, the imbalance in the ratio of melody Ts to morpheme TBUs is solved through spreading of (both the /H/ and the /L/) tones, or through contour simplification and re-association strategies to ensure that each TBU is assigned one and only one surface tone. As a result, the TBUs of toneless noun roots receive surface tone through tone spreading from the affixes in the noun. This causes them to alternate between H-toned after an H-toned prefix or L-toned after an L-toned

prefix, through a left-to-right spreading, but always H-toned as the H of their /H/ or /HL/ suffix melodies, through a default right-to-left spreading, in the absence of the prefix when the nouns occur in isolation (as in a wordlist). For the four groups of roots that have underlying tone, the underlying tonal melodies can only be slightly altered, but in a different way during noun formation to exhibit downstep anytime the affixation creates a /HLH/ sequence, in which the L is singly linked.

Five underlying melodies have been determined on verb roots: /H/, /L/, /HL/, /LH/, and /LHL/. Verb roots hence include an extra melody than noun roots, but unlike noun roots, no toneless verb roots have been encountered. The derivation of deverbal adjectives and deverbal substantives in which the verb roots have been examined follows exactly the same rules as the derivation of nouns. Downstep phenomenon also occurs in verbal form as in nouns. However, tone spreading will usually be prevented in these deverbal forms because verb roots usually have an equal or greater number of Ts in their melodies as the TBUs on their segmental tier. In the tone association, the epenthetic vowel, which is usually inserted between roots and suffixes to split consonant clusters, also serves to carry the extra T in verb root melodies. It has appeared, therefore, that this language tends to preserve underlying tones.

CHAPTER 7

CONCLUSION

7.1 Overview of the Significant Findings

This final chapter overviews the significant findings of the study and gives some perspectives for further research, which relate to the segments and tones of Kabiye.

Based on an assessment of the handful of segmental and tonal descriptions found amid a recently growing literature on Kabiye, research questions were stated, the answers to which would help revise the phonology and resolve competing results in the previous analyses. For the purpose, a more systematic and in-depth reanalysis of the segments and tone have been combined with more current phonological theories and tools to find answers to these research questions. The study's results have confirmed parts of the results in previous studies, but at many points, it has also resulted in findings that are not in agreement with any of the previous studies. Accordingly, significant revisions have been proposed to the segmental and tonal phonology, the presentation of which endeavored to build upon the existing descriptions.

7.1.1 Consonant System

As an answer to the first research question that asked what the phonetic and phonological segments of Kabiye were, Chapter 4, which revises the consonantal phonology, presented the current study's new phonetic inventory of consonantal

segments, which is almost identical to the previous phonetic inventory of consonants (in Lébikaza 1999: 87-88, 91), except in one important segment and a lesser important detail in another segment. Neither a velar glide nor a segment “[ɣ]” as defined in Lébikaza’s work (and in virtually all the preceding studies on Kabiye) is found in contemporary Kabiye. In addition, Lébikaza’s alveolar flap [ɾ] is replaced by the more appropriate IPA retroflex flap [ɽ].

The phonological analysis of the consonants has brought an important revision to the inventory of obstruents, namely an underlying contrast in voicing. Examination of the voiced and voiceless obstruents alternations in the current study determined that two main factors affect voiced and voiceless obstruents in this language, unlike what was previously determined in Lébikaza 1999. The first factor is a phonological rule that devoices obstruents in utterance-initial positions (defined as positions that coincide with the beginning of a sentence, the beginning of a word occurring after a pause in a sentence, or the beginning of a word occurring in isolation, as in a wordlist). Adding to an already existing restriction on the distribution of consonants in word-final position, such a rule leaves voiced versus voiceless obstruents contrasts only in medial positions (both in the bare root and after a morpheme boundary). However, in the bare root, only the alveolar pairs /t/ vs. /d/ and /s/ vs. /z/ contrast through minimal pairs, though other voiced and voiceless obstruents are seen. After a morpheme boundary, voiced and voiceless obstruents are also seen in similar positions, but a second conditioning factor, which is of morphological nature, also affects obstruents; some specific constructions in

the language carry a floating voicing feature, so that all root-initials obstruents are always voiced in the environment of these constructions. But other constructions or environments are voicing-neutral such that a contrastive use of voiced and voiceless obstruents are seen in these environments. Consequently, in the voicing-neutral environments, the underlying inventory of obstruents is determined, which includes all the phonetic obstruents except the voiceless bilabial [p] and retroflex [t]. Attesting both voiced and voiceless contrastive obstruents in the crucial voicing-neutral positions had a direct replication on the outcome of the new analysis; the inventory of contrastive consonants grew significantly. In addition to obstruents, another revision was made to the class of nasals, which now explicitly includes a nasal archiphoneme previously alluded to by Delord 1976; on the other hand, it has reaffirmed, following Lébikaza (1985, 1999), that the controversial velar nasal [ŋ], is not a contrastive segment. The unattested velar “/ɣ/” from earlier studies, is also not part of the revised consonant system. Other confirmed contrastive consonants include the liquid /l/ and the approximants /j w h/.

In comparing the new phonological consonant system (Table 4.3) to the ones from previous studies, it is apparent that the new inventory resembles them in some ways, but it also departs from them in others. The new consonant table bears the most resemblance to the phonological inventory of the CLNK & SIL-Togo 1998 (Table 2.7 on page 62), and to the one of Paaluki 1995 (Table 2.9), to a lesser extent. This is mainly seen in the first half of the new consonant table constituted by obstruents.

7.1.2 Vowel System

The new analysis presented in Chapter 5, which answers the second main research question, has also revised the analysis of vowels. In addition to the nine short vowels phonemes /i ɪ e ε a o u ɔ ʊ/ common to all earlier vocalic systems, the revised phonological vocalic system also includes the nine long vowels /ii ɪɪ ee εε aa oo uu ɔɔ ʊʊ/ and a vocalic archiphoneme represented as /K/.

This vocalic system is realized by a total of 55 vocoids. 18 of these vocoids, which already appeared in Lébikaza 1999, are monophthongs that form a symmetrical phonetic system (Table 2.1). The other vocoids included long vowels, extra long vowels, and three types of diphthongs. The vocalic archiphoneme, which is an underspecified segment, is not entirely realized in any single one of the 55 vocoids, but only partly comprised in some of them. It is a segment specified for only three features as [-consonantal, +back, -round] and takes the rest of its features in context from the vowel that precedes it. Therefore, it is realized as the back unrounded vocoids [ɯ ʊ ɤ ʌ ɑ] when it is preceded by the unrounded front vowels /i ɪ e ε a/, respectively, as the rounded high back vocoid [u] after the rounded back vowels /o u/, and as the rounded back high vocoid [ʊ] when it occurs after the rounded back vowels /ɔ ʊ/. Following the rounded back phonemes, therefore, the realizations [u] and [ʊ] of the archiphoneme merge phonetically with those of the back phonemes /u/ and /ʊ/. Hence, in the perfectly symmetrical phonetic system of 18 monophthongs, the unrounded back vocoids [ɯ ʊ ɤ ʌ ɑ] derive from both the archiphoneme and each of the unrounded front phonemes /i ɪ

e ε a/, respectively. On the other hand, the rounded front vocoids [y ɤ ø œ] derive from the rounded back vowels /o ɔ u ʊ/, respectively. The vocalic archiphoneme, which occurs mainly as a suffix, has exactly the same surface realizations after the long counterpart front and back phonemes. These long phonemes, however, will not surface as long in these contexts, but they will most likely undergo a vowel shortening. Indeed, the revised vocalic analysis has provided good grounds on which the phonological status of the long vocalic phonemes that were listed in some of the earlier studies should be confirmed. In contrast, extra long vowels and the three types of diphthongs have been shown to be non-contrastive.

In comparing the new analysis' results to the ones in previous studies, it can be said that the revised vocalic system has not confirmed the results of any single one of the earlier studies, but it has confirmed only parts of their results while introducing new ones. The initial inventory of vocoids identified by the current study is almost identical to the one presented in Lébikaza 1999, except for the third type of diphthongs (diphthongs gliding from a rounded back vowel or an unrounded front vowel to an unrounded high front vowel – see Figure 5.5), which were overlooked in Lébikaza 1999. The revised vocalic analysis has confirmed the nine short phonemes on which all studies are in agreement, but which are the only contrastive vowels according to Delord 1976, Paaluki 1995, Kassan 1996, and Lébikaza 1985/1999. But the current analysis has also confirmed the long contrastive vowels proposed by Roberts (2002, 2003) and

CLNK & SIL-Togo (1998). However, the revised phonological vocalic system departs from the latter works in a single important extra element, the vocalic archiphoneme /K/.

The vocalic archiphoneme can be reconciled with these former studies to some extent. The choice of /K/ (“Big K”) to represent the vocalic archiphoneme identified in Kabiye is based on what is believed to be its segmental origin, as known from Delord’s study of early Kabiye forms in Koelle’s work. But the archiphoneme /K/ is similar to Lébikaza’s velar glide (which is also Delord’s velar fricative) /ɣ/, which might have been a transitory segment in the historical evolution of the archiphoneme. Hence, this /ɣ/ could have transitioned from the consonant system into the vocalic system as the vocalic archiphoneme. An archiphoneme in the vocalic system is also consistent with the common understanding that has emerged from the remaining earlier studies about their extra vocalic phonemes. The archiphoneme reflects the oneness of the underlying segment in their extra vocalic phonemes, which these earlier studies represented with the same symbol – whether graphically or as a symbol – as reflected in their “long pharyngealized” vowels /iʏ iʔ eʏ eʔ aʏ/ (Roberts 2002: 10, CLNK & SIL-Togo 1998, pp.1-2 of *Esquisse de Grammaire Kabiye*, Paaluki 1995: 16) or velarized allophones [iʏ iʔ eʏ eʔ aʏ] (in Padayodi 2008; also seen in the reported early forms listed in Koelle 1854⁵⁴). Furthermore, these earlier works also clearly understood the connection of the vocalic archiphoneme to the front phonemes, since they always paired the /ɣ/ with one

⁵⁴ Velarized notations were already witnessed along with [ɣ] and [ɣ̠] or [ɣ̡] notations in some of the early forms of Kabiye from the work of Koelle as reported by Delord (viz. *déyá* [dɛ̠yá] ‘house’, *nóy* [nɔ̠y] ‘mouth’, *mancaýá* [manca̠yá] ‘I am sited’ in Delord 1976: 450-451).

of the front vowels (as seen in their notations). Under the current analysis, those combinations correspond to the (first type of) phonetic diphthongs [iɥ iɯ eɣ ελ aɔ], respectively (see Figure 5.3). In other respects, like the /ɣ/ of Lébikaza (1999), the vocalic archiphoneme also provides grounds for a better explanation of all the deriving vocalic elements that represent the morpheme of the Inaccomplished, and thus grounds for dismissing the long pharyngealized vowels of Roberts (2002, 2003) and the CLNK & SIL-Togo (1998) as phonemes. Yet, better than the /ɣ/, which is no longer attested as such in the contemporary form of the language, the understanding of the vocalic nature of the archiphoneme /K/ in the current analysis more appropriately relates this underspecified segment to the phonetic elements that represent it in the vocalic system.

Another important revision was made to the traditional description of the difference between the two series of Kabiye vowels as relating to the tongue root advancement (ATR) in the articulation of one series versus its lack in the other series. This revision was necessary to reflect the reported findings of the recent laryngoscopic case studies of Edmondson & Esling 2006 and Edmondson *et al.* 2007, which showed that the laryngeal mechanism in the articulation of Kabiye vowels involved not only a retracted tongue, but also a constriction of the aryepiglottic fold. The description of the two series of vowels was accordingly revised in terms of [RTR] (for Retracted Tongue Root) and [CONSTR] (for constricted aryepiglottic fold): the traditional [-ATR] series of vowels produced with a Retracted Tongue Root and a constricted aryepiglottic fold has been associated with the new label [+CONSTR]/[+RTR] and the traditional

[+ATR] series of vowels that are produced with a lack of both constriction and tongue root retraction has been associated with the new label [-CONSTR]/[-RTR].

Hence, the revisit of Kabiye segmental phonology has led to a general revision of the understanding of the analysis vowels and consonants at the phonetic and phonological levels. In addition to the analysis itself, the contribution of the new study to the phonology also applies to the resulting inventories. From their underlying forms to their surface manifestations, many of the consonants and vowels of Kabiye undergo important alterations, which make them become alike on the surface in same environments. Therefore, minimal pairs are not sufficient to uncover all the sounds that are contrastive among those inventoried at the phonetic level. The alterations hold the key information that can lead to a determination of the contrastive segments.

7.1.3 Contrastive Tones and Lexical Tonal Melodies

Tone analysis in Chapter 6, which answers the third main research question, has revised the lexical tonal melodies of noun roots and verb roots as well as those of the nominal suffixes and also shown some acoustic characteristics of tone through investigation of pitch tracks and F_0 measurements.

The acoustic analysis has investigated the pitch tracks of high and low tones and those of high-low and low-high tone sequences and found that the high tone and the low tone manifest quite opposite pitch trajectories. The high tone is characterized by a gradual rise (i.e., an upward movement) and the low tone by a gradual fall (i.e., a downward movement) in the pitch trajectory, but with a bigger slope for the low tone

than the high tone. On the other hand, the pitch trajectories of the high-low and the low-high tone sequences do not correspond to their phonological autosegmental understanding. The trajectory of the high-low sequence is gradually and steadily falling (i.e., a downward movement), in a way quite similar to the trajectory of the low tone, but with a steeper and bigger slope. The low-high sequence manifests a gradual rising trajectory that is also quite similar to the trajectory of the high tone, but with a steeper and bigger slope.

The phonological analysis has confirmed the /H/ and the /L/ as the only distinctive tones of Kabiye, but it has revised the tonal melodies specified on the basic component morphemes of the word, which are roots and affixes. The current study has identified five groups of noun roots, one of which includes toneless roots (/T₀/ roots) and the other four groups of noun roots specified for lexical tonal melodies as /H/, /L/, /HL/, and /LH/. The study has also indicated five groups of verb roots, but with slightly different lexical tonal melodies, which are H/, /L/, /HL/, /LH/, and /LHL/. Noun suffixes, which attach to noun roots and verb roots (to derive relational locatives in Kabiye from verb roots), have been determined to carry the same tonal melodies as noun roots, which are /H/, /L/, /HL/, and /LH/. Prefix pronouns, on the other hand, have been determined to carry only two melodies, which are /H/ and /L/.

In the phonological word constituted of the noun root or the verb root and affixes (optional prefix and noun class suffix), the surface tonal pattern of the noun is quite consistent with the lexical tonal melodies of the component morphemes, which

undergo little or no change. The main phonological alteration that the lexical melodies may undergo is the downstep phenomenon, which occurs in any /HLH/ sequence, when the /L/ is singly associated. Noun of toneless roots, on the other hand, exhibit significant tonal alternations due to their toneless root TBUs receiving surface tones from the affixes through spreading of the H tone (HTS) or the L tone (LTS). Therefore, the roots of these nouns carry the same tone as the prefix in the noun, or as the H tone from their /H/ or /HL/ suffix melodies.

7.2 Directions for future research

While the current study has led to a fuller understanding of Kabiye phonology, there are a number of phenomena that merit additional study, both phonologically and phonetically. For example, under the current study, the understanding of existing devoicing-environments, voicing-environments, and voicing-neutral environments in Kabiye, accounts for most of the data (virtually all noun roots and roughly 90% of verb roots) but still leaves a few exceptions. These exceptions relate to a very small percentage of data – verb roots, specifically, illustrated by the verbs ‘to massage’ and ‘to die’ (in Table 4.8 on page 176), for which it remains unclear what determines the surfacing of the voicing specification of the initial obstruent. Though these verbs tend to follow the same pattern as most other verbs, they occasionally exhibit unexpected voicing specifications of the initial obstruent in the voicing-neutral environments. The roots constituting this small percentage would benefit from further investigation; of

particular interest would be knowing the extent to which this apparently marked pattern is found in other root paradigms.

The analysis developed under the current study has shown that morphology plays a role in the surfacing of the underlying voicing specifications of obstruents based on which most of the contrastive voiced and voiceless consonants can be identified in Kabiye. The new account presented in the current study does explain virtually all the data, though with some inconsistency in a small percentage of the data. A future avenue would be to pursue the revised analysis from a language typology perspective to find out if some related African languages present similar morpho-phonological patterns.

In other respect, the study of the sounds of Kabiye can be furthered in many other ways, such as from a diachronic and a variation perspective. A study of consonants or vowels from a historical linguistics point of view could seek possible diachronic change in other consonants or vowels than the vocalic archiphoneme. The consonants or vowels could also be studied from a dialectal variation perspective, to determine the rules that apply to segments (and probably to tone as well) in the non-standard varieties of Kabiye. For instance, through some contact during the current investigation, it was apparent that in the Kabiye variety of Koumea the voicing-neutral environments distinction was not made like in the Kèwe varieties studied in this research. This raises the serious question of how (or if at all) this variety contrasts voiced and voiceless consonants underlyingly.

Tone investigation, which is limited to the phonological word, needs to be furthered in order to uncover and describe tonal alterations that lie beyond the word, such

as sentence-level and potential discourse-level tonal alterations. An acoustic study of tonal phenomena, such as declination, downstep, and downdrift, can also be conducted to show their phonetic nature and show how differently they might be manifested, and how they might also compare to the phenomena described in similar terms in other related or non-related tone languages.

Based on the results of the current tone investigation, some suggestions can be made regarding the issue of marking tone in the writing system of Kabiye. This study has shown that Kabiye contrasts only two level tones, /H/ and /L/. Further, it has determined that there is only the tonal phenomenon of downstep that occurs at the word level. By this phenomenon, the contrastive tones in a sequence of /HLH/, where the /L/ is associated to a single TBU, become realized as [HMM], which brings the number of pitch levels of tone to three, as [H], [M], and [L]. As a starting point of showing tone in the orthography, these three word-level pitch distinctions in tone can be shown as [´], [¯], and [], respectively, as is already being done in some languages that contrast three tones. Alternatively, downstep could also be indicated by a superscripted exclamation point (!) before the syllable with the affected H-toned TBU, as it is done in phonological transcriptions. In either case, however, there will be a need for an additional way of indicating further sentence-level tonal alterations, such as downdrift, which tend to allow for more pitch levels than the ones seen at the word-level. Study of sentence-level tone manifestations could better contribute to the understanding of how to represent those tonal alterations.

APPENDIX A

TONAL FRAMES

Examples of the substitution frames:

Frame 1

[tò zì _____ d̥d̥d̥] ‘say _____ again’

Frame 2

[á ní _____ é ná] ‘who has ever heard _____?’

Frame 3

[pà- _____] ‘their-_____’

Frame 4

[ná- _____] ‘your-_____’

Frame 5

[kí- _____] ‘(Adjr)’

Frame 6

[d̥ _____] ‘(Pref.)’

APPENDIX B

WORD GAMES

Game

Example 1:

Noun: [èjú] ‘person’

Verb: [ʔádlòù] ‘to be tall’

Adjective = [èjú kí-ʔādl-ù] ‘tall person’

Example 2:

Noun: [ʔùm] ‘snake’

Verb: [síbù] ‘to die’

Adjective = [ʔùm kí-sīb-ù] ‘dead snake’

APPENDIX C

SAMPLE NOUN ROOTS AND VERB ROOTS

/àbal-/	‘male, man’	/ɖʒàkɔ̀pada-/	‘species of snake’
/àɖɛj-/	‘countries’	/ɖàl-/	‘brother’
/àgòòz-/	‘weeding’	/ɖʒàɲkèl-/	‘a sieve’
/àgúlùmgu-/	‘vulture’	/ɖʒèt-/	‘to lie’
/akaj-/	‘(a species of snake)’	/ɖàz-/	‘rotten’
/àkoj-/	‘non-ripe fruit’	/ɖɔ̀ɔ̀-/	‘to grow many’
/àlèèw-/	‘devil’	/dòk-/	‘eat’
/àtɛj-/	‘hooves’	/ɖɔ̀m-/	‘salt’
/àtej-/	‘mahogany fruit pod’	/ɖòNd-/	‘age group’
/átɛj-/	‘adultery’	/ɖé-/	‘good’
/àvɛj-/	‘jubilation’	/ɖèɛ-/	‘leave’
/bàz-/	‘start’	/ɖèeb-/	‘sauce pan’
/bé-/	‘kernels’	/ɖèj-/	‘to flatter’
/bé-/	‘stones’	/dàna-/	‘joke’
/bèd-/	‘to sell’	/dèl-/	‘baobab tree’
/bèènd-/	‘to lament’	/dèm-/	‘finish’
/bèl-/	‘girl’	/dèt-/	‘earth, ground’,
/bèm-/	‘to deprive’	/dètíj-/	‘struggle’
/bɪɖɔ̀-/	‘scorpion’	/díɪm-/	‘gun powder’
/bíj-/	‘stone’	/doj-/	‘your warthog’
/bìjal-/	‘son’	/ɖòó-/	‘night’
/bìm-/	‘burry’	/ɖòo-/	‘to sleep’
/bìn-/	‘to grow old’	/dòoven-/	‘truth’
/bìz-/	‘to succeed’	/ɖùɪm-/	‘snake’
/bó-/	‘palm tree’	/ès-/	‘eye’
/bódq-/	‘mosquito’	/èsó-/	‘God’
/bòz-/	‘to ask’	/ègbé́l-/	‘maternal uncle’
/ból-/	‘daughter-in-law’	/èveb-/	‘young man’
/bùdòd-/	‘pity’	/fèb-/	‘massage’
/ɖʒàa-/	‘rest’	/fèé-/	‘shame’
/ɖʒaafel-/	‘a turtle’	/fèm-/	‘awake’
/ɖàál-/	‘to get long’	/gbàamz-/	‘pepper’
/ɖʒàK-/	‘sit’	/gbàK-/	‘take’

/gbàtʃa-/	‘a machete’	/kàd-/	‘resist’
/gbèlɛk-/	‘learn’	/kapa-/	‘meanness’
/gbín-/	‘animal’	/kèd-/	‘be good’
/gèles-/	‘rinse’	/kel-/	‘tooth’
/gét-/	‘peanut’	/kì-/	‘fat’
/gìs-/	‘look back’	/kíl-/	‘forehead’
/gít-/	‘return’	/kìmelem-/	‘idiot’
/gòdʒó-/	‘fly’	/kìz-/	‘to refuse’
/goo-/	‘water pot’	/kój-/	‘medicine’
/gùdʒuk-/	‘Sunday’	/kò-kò-/	‘gourd’
/gùjɔ-/	‘suffering’	/kól-/	‘to exorcize’
/há-/	‘give’	/kòɔ-/	‘come’
/hab-/	‘road’	/kòj-/	‘to pick up’
/háj-/	‘farm’	/kòob-/	‘kinship’
/háK-/	‘dog’	/kpá-/	‘catch’
/hàk-/	‘a plow’	/kpá-/	‘to climb’
/hàl-/	‘female, woman’	/kpàam-/	‘insanity’
/hàz-/	‘sweep’	/kpám-/	‘to hunt’
/hé-/	‘goat’	/kpèl-/	‘chair’
/hèj-/	‘to pay’	/kpèm-/	‘go home’
/híz-/	‘cut’	/kpéz-/	‘to cough’
/hòól-/	‘to carry on shoulder’	/kpèz-/	‘to uproot’
/hòlós-/	‘to sip’	/kú-/	‘to kill’
/húj-/	‘have diarrhea’	/kùbu-/	‘a loud cry’
/hùu-/	‘to soften’	/kùdɔm-/	‘sickness’
/jàb-/	‘buy’	/kùj-/	‘to stand up’
/jàb-/	‘buy’	/là-/	‘wilderness’
/jòòd-/	‘talk, speak’	/lá-/	‘forest’
/jòk-/	‘to break’	/làa-/	‘to immolate’
/jósɔ-/	‘mother-in-law’	/láb-/	‘do’
/jòo-/	‘fight’	/làk-/	‘action’
/kàaw-/	‘rock’	/làNhulum-/	‘joy’
/kàbrje-/	‘Kabiye’	/lèb-/	‘to get lost’

/lɛɛ-/	‘to wear (shoe, etc.)’	/ná-/	‘to see’
/lɛj-/	‘to play’	/nám-/	‘antelope’
/lɛj-/	‘to be first’	/náNd-/	‘meat’
/lɛK-/	‘to snatch’	/nɔ-/	‘cow’
/lɛm-/	‘dry (in the sun)’	/nɔɔ-/	‘mouth’
/li-/	‘neck’	/nɛze-/	‘grandmother’
/lib/	‘to swallow’	/Ñgb-/	‘alliance’
/lii-/	‘to dip’	/niɪ-/	‘to understand’
/liɪ-/	‘to get out’	/nim-/	‘to become convex’
/lím-/	‘water’	/nim-/	‘rope’
/lòm-/	‘cut at’	/Ñzulom-/	‘tongue’
/lòo-/	‘to serve (food)’	/sám-/	‘to praise’
/lɔ-/	‘to throw’	/sɔ-/	‘venom’
/lɔb-/	‘to thatch’	/sɔɔ-/	‘to forget’
/lɔɔɔ-/	‘car’	/sɔj-/	‘to aspirate’
/lú-/	‘to whip’	/sɔɔ-/	‘mortar’
/lùb-/	‘to wrestle’	/sé-/	‘to run’
/lùb-/	‘to forge’	/sɛ-/	‘to benefit’
/lùl/	‘to deliver’	/sɛj-/	‘grandchild’
/lùu-/	‘to weave’	/sɛK-/	‘to lift up’
/má-/	‘rice’	/sɛz-/	‘reach’
/màb-/	‘to beat’	/sìb-/	‘to die’
/mìKn-/	‘nasal mucus’	/sìd-/	‘to mix’
/mìl-/	‘to steal’	/sìɪ-/	‘lay down’
/mɔɔ-/	‘noses’	/sìm-/	‘to know’
/mɔɔj-/	‘bone’	/sómòl-/	‘papaya’
/múz-/	‘to groan’	/sú-/	‘hernia’
/ɲá-/	‘bitterness’	/sú-/	‘Nereid fruit’
/ɲàm-/	‘heart’	/sùlum-/	‘to ask for’
/ɲàs-/	‘to bite’	/sùu-/	‘to enter’
/ɲím-/	‘wealth’	/sú-/	‘tail’
/ɲɔɔ-/	‘to drink’	/sùm-/	‘be quite’
/na-/	‘bovide’	/súz-/	‘to publicize’

/tʃà-/	‘want’	/tó-/	‘a bow’
/tʃàá-/	‘father’	/tó-/	‘to shoot’
/tʃàK-/	‘sit’	/tóm-/	‘language’
/tʃàlím-/	‘blood’	/tɔɔna-/	‘food’
/tʃàt-/	‘sift’	/tú-/	‘bee’
/tʃa-tʃa-/	‘grasshopper’	/tú-/	‘elephant’
/tʃèl-/	‘to hand over’	/tulut-/	‘stupidity’
/tʃèt-/	‘lie’	/tùm-/	‘to clear (land)’
/tʃij-/	‘to tear’	/tòm-/	‘work’
/tʃóɔɔ-/	‘priest’	/vèé-/	‘shame’
/tʃòz-/	‘to take some’	/vèt-/	‘to fan’
/tʃùlís-/	‘to sharpen’	/vet-/	‘toads’
/tʃùul-/	‘navel’	/wàb-/	‘to win’
/tákàj-/	‘book’	/wàɔɔ-/	‘to demolish’
/tál-/	‘arrive’	/wíj-/	‘king’
/tál-/	‘arrive’	/wís-/	‘sun’
/tám-/	‘to bind’	/wòb-/	‘to go’
/tè-/	‘to sustain’	/zàɔɔ-/	‘frog’
/tèe-/	‘to sing’	/zèm-/	‘rat’
/tèjí/	‘(twin male name)’	/zèt-/	‘to cut’
/téKlím-/	‘clear top of a drink’	/zìK-/	‘to plant’
/tèm-/	‘to finish’	/zím-/	‘death’
/tí-/	‘tree’	/zó-/	‘odor’
/tìz-/	‘to cook’	/zòkɔɔl-/	‘(fufu) meal’
/tìm-/	‘to cut down’	/zòɔɔt-/	‘mess’

REFERENCES

- Adji, Aklesso. 1996. *L'insaisissable destinée humaine: la mort et les apories de la vie chez Schopenhauer et chez les Kabiye*. Université de Poitiers, France (doctoral dissertation).
- Adjola, R.P. 1978. *Kabiye Mau*. Centre régional de l'institut national de la recherche scientifique, Kara.
- Akanlig-Pare, George. 1997. Tonal structure of Buli phonological nouns. *Gur Papers / Cahiers Voltaïques* 2, 63–67.
- Ali-Napo, Pierre. 1997. *Histoire des travailleurs-manœuvres et soldats du nord-Togo au Temps Colonial: 1884-1960*. Lomé: Presses de l'Université du Bénin.
- Alou, Patrice Jojo. 1984. *La conception de dieu appelle eso chez les kabiye du togo, en Afrique occidentale et l'originalité du Christianisme*. Vatican City: Pontificia Universitas Lateranensis (doctoral dissertation).
- Badameli-Kassan, Balaïbaou. 2000. De l'influence du ton consécutif dans les formes de l'aoriste en kabiyè. *Cahiers voltaïques / Gur Papers* 5, 13–22.
- Badameli-Kassan, B. 2001. Morphologie des noms propres de personne en kabiyè. *Journal de la Recherche Scientifique de l'Université de Lomé (Togo)* 5, vol 2, 67–78.
- Beckman, N. Jill. 1997. Positional Faithfulness, Positional Neutralisation and Shona Vowel Harmony. *Phonology*, 141–146.

- Black, Andrew H. 1996. Sketch of Autosegmental tonology. *Notes on Linguistics* 72, 5–14.
- Brenzinger, Matthias (ed.). 2007. *Language diversity endangered*. Berlin: Mouton de Gruyter.
- Brungard, R.P. 1937. *Dictionnaire kabiyè-français*. Lomé: Imprimerie ND de la providence.
- Burquest, Donald A. 2006. *Phonological Analysis: A Functional Approach*. Third edition (1st ed. in 1993). SIL International.
- Cahill, Mike. 2007. More Universals of Tone. *SIL Electronic Working Papers 2007-007 10 p.* <http://www.sil.org/silewp/abstract.asp?ref=2007-007>
- Chrystal, David. 1997. *A dictionary of linguistics and phonetics*. 4th edition, Blackwell, Oxford.
- CLNK and SIL-Togo 1998. *Tòm kpou Kabiyè-Fransu: Dictionnaire Kabiyè-Français avec Lexique Français-Kabiyè et Esquisse de Grammaire Kabiyè*. CLNK and SIL, 1st ed.
- CLUB DE LANGUE KABUYÈ. 1990. *Journal du Club Kabiyè: TEBIYÈ N°8*, Université du Bénin, Lomé.
- CLUB DE LANGUE KABUYÈ. 1994. *Journal du Club Kabiyè: TEBIYÈ N°10*, Université du Bénin, Lomé.
- Collins, Chris and Komlan E. Essizewa. 2007. The Syntax of Verb Focus in Kabiye. *Selected Proceedings of the 37th Annual Conference on African Linguistics*, ed. Doris L. Payne and Jaime Peña, 191–203. Somerville, MA: Cascadilla Proceedings Project. www.lingref.com, document #1606.

- COMITE REGIONAL DE LANGUE KABIYE. 1983. Kara : *Kúḍvín láktí wé*.
- COMITE DE LANGUE NATIONALE KABIYE –Togo. 1994. *EBE LABA* N°15,
Revue Semestrielle, Lomé, Kara.
- COMITE DE LANGUE NATIONALE KABIYE –Togo. 1995: *EBE LABA* N°18,
Revue Semestrielle, Lomé, Kara.
- Connell, Bruce and D. Robert Ladd. 1990. Aspects of pitch realisation in Yoruba.
Phonology 7, 1–29.
- Connell, Bruce. 2001. Downtdrift, Downstep, and Declination. *Proceedings of Typology
of African Prosodic Systems Workshop (TASP)*. Germany: Bielefeld University.
- Creissels, Denis. 1994. *Aperçu sur les structures phonologiques des langues négro-
africaines*. Ellug, Grenoble.
- Cridel, B. 1968. *Légendes, proverbes et devinettes kabré*. Doc. du CerK.
- Cridel, B. 1968. *10 contes kabré*. Doc. du CerK.
- Crystal, David. 1997. *A Dictionary of Linguistics and Phonetics*. Blackwell Publishers
Ltd. 4th Ed.
- Delord, Jacques. 1968. Sur le kabré du Togo – Jeux de tons. *Bulletin de l'IFAN* XXX,
1, 256–268.
- Delord, Jacques. 1968. Le kaure de la polyglotta africana et le kabré d'aujourd'hui.
African Language Review 7, 114–139.
- Delord, Jacques. 1974. *Morphologie abrégée du kabré*. Documents linguistiques 4,
Université de Dakar.

- Delord, Jacques. 1976. *Le Kabiyè*. Institut national de la recherche scientifique, Lomé.
 DI.FO.P. *Kunuŋ Paytu Takayay*. S. ed., Lomé.
- Durand, Jacques. 1990. *Generative and Non-Linear Phonology*. Longman Group UK Limited.
- Edmondson, Jerold A. and John H. Esling. 2006a. The valves of the throat and their functioning in tone, vocal register and stress: laryngoscopic case studies. *Phonology* 23, 2, 157–191.
- Edmondson, Jerold A. and John H. Esling. 2006b. The laryngeal basis for the feature [ATR]. Paper delivered at the Annual Conference on African Linguistics, university of Oregon, Eugene. April 9, 2006.
- Edmondson, Jerold A., Cécile M. Padayodi, Zeki M. Hassan and John H. Esling. 2007. The laryngeal articulator: source and resonator. *International Congress of Phonetic Sciences XVI*, ID 1674, 2065–2068.
- Edmondson, Jerold A., Cécile M. Padayodi, David J. Silva, and John H. Esling. 2008. The laryngeal basis of the feature [ATR]. Unpublished manuscript.
- Esling, John H. 1996. Pharyngeal consonants and the aryepiglottic sphincter. *Journal of the International Phonetic Association* 26, 65–88.
- Esling, John H. 2005. There are no back vowels: The laryngeal articulator model. *Canadian Journal of Linguistics* 50, 13–44.
- Essizewa, Komlan E. 2003. Aspects of Kabiye tonal phonology and implications for the correspondence theory of faithfulness. *Proceedings of the Eleventh*

- Student MIT Working Papers in Linguistics* 45, 35-47.
- Essizewa, Komlan E. 2006. Sociolinguistic survey of language contact in Togo: A case study of Kabiye and Ewe. *Journal of West African Linguistics (JWAL)* 33, 1, 35–51.
- Essizewa, Komlan E. 2007. Language Contact Phenomena in Togo: A Case Study of Kabiye-Ewe Code-switching. In *Selected Proceedings of the 37th Annual Conference on African Linguistics*, ed. Doris L. Payne and Jaime Peña, 30–42. Somerville, MA: Cascadilla Proceedings Project.
- Essizewa, Komlan Essowe. 2007. Sociolinguistic aspects of Kabiye-Ewe bilingualism in Togo. New York: New York University (PhD dissertation).
- Farnham, Dana Arthur. 1994. *Animal traction at Agbassa: The change from hoes to plows on a government-sponsored land settlement project in northern Togo*. San Diego: University of California (PhD dissertation).
- Garr, Randall W. 1986. On Voicing and Devoicing in Ugaritic. *Journal of Near Eastern Studies*, 45, 1, 45-52. The University of Chicago Press.
- Goldsmith, John. 1976. An Overview of Autosegmental Phonology. *Linguistic Analysis* 2, 1, 23–68 *American Elsevier Publishing Company, Inc.*
- Goldsmith, John. 1990. *Autosegmental and metrical phonology*. Blackwell, Oxford. (MIT PhD dissertation, 1976).
- Greenberg, H. Joseph. 1963. The Languages of Africa. Indiana University, *Bloomington*.
- Hargus, Sharon and Kaisse, Ellen M. ed. 1993. Studies in Lexical Phonology. Series Phonetics and Phonology, v. 4. San Diego: *Academic Press*.

- Harrison, David K. 2007. *When languages die: the extinction of the world's languages and the erosion of human knowledge*. Oxford: Oxford University Press.
- Hartmut, Traunmüller and Anders Eriksson. 1995. (manuscript) The frequency range of the voice fundamental in the speech of male and female adults, Institutionen för lingvistik, Stockholms universitet, S-106 91 Stockholm, Sweden.
- Heine, Bernd and Kézié Lébiakaza. 1997. On Attributive Possession in Kabiye. In *Essays on Language Function and Language Type: Dedicated to T. Givón*, 217–230. Joan Bybee, John Haiman, and Sandra A. Thompson (eds.). Amsterdam: John Benjamins.
- Heine, Bernd et Nurse, Derek ed. 2000. *African Languages, an introduction*. Cambridge University Press, Cambridge, England.
- Hyman, Larry M. 1993. Structure Preservation and Postlexical Tonology in Dagbani. *Phonetics and Phonology. Studies in Lexical Phonology*, 4, 235–254. Hargus, Sharon, and Kaisse, Ellen M. (eds.). San Diego, CA: Academic Press, Inc.
- Hyman, Larry M. and Armindo Ngunga. 1994. On the non-universality of tonal association 'conventions': evidence from Ciyao. *Phonology* 11, 25–68.
- Hyman, Larry. 2007. Universals of Tone Rules: 30 Years Later. In C. Gussenhoven & T. Riad (Eds.), *Tones and Tunes: Studies in Word and Sentence Prosody* (pp.1–34). Berlin: Mouton de Gruyter.
- Inkelas, Sharon and Draga Zec ed. 1990. The Phonology-Syntax Connection. Chicago and London: *The University of Chicago Press*.
- IPA (International Phonetic Association). 1999. *Handbook of the International Phonetic*

- Association: A guide to the use of the International Phonetic Alphabet.*
Cambridge: Cambridge University Press.
- KAO, Blanzoua W. 1990. *ɛbekalamwaaa cɔlvu pɔɔ*, Lomé, 79p, rénéotypé.
- KAO, W. Blanzoua, 1991. *Naale yaa Nastle*. Recueil de texte, s. éd., Lomé.
- KAO, W. Blanzoua, 1991. *PAÑAIŋ, Kɔɔnɔɔ ñɩŋga*, Recueil de texte, s. éd., Lomé.
- KAO, Blanzoua W. 1993. *Kabiyedu ne ɛ-sɔŋzi, kɔɔnɔɔ hɔɔlvu*. Recueil de textes, s.éd.
- KAO, Blanzoua W. 1993. *Kabiyedu ne ɛ-sɔŋzi, hɔɔlvu kɩlɩlvu, (Habiyɛ)*. Recueil de
texte, s. éd.
- KAO, Blanzoua W. 1993. *Kabiyɛ caanaɔ taa tɔm*. Presse de l'UB.
- KAO, Blanzoua W. 1999 : *Histoire Générale des Kabiyɛ* (origine et peuplement),
Editions Afri-Imprim.
- Karan, Mark E. 1983. Comparaison entre les discours narratifs kabiyè et lukpa. In
Jacques Nicole (ed.), *Études linguistiques préliminaires dans quelques langues
du Togo*, 158-64. Lomé: Société Internationale de Linguistique.
- Kassan, Balaïbaou. 1996. *Système Verbal et Enonciation en Kabiyè*. Paris III:
Université de la Sorbonne Nouvelle (doctoral dissertation).
- Kassan, Balaïbaou. 2001. Des constructions prédicatives injonctives et interrogatives
pour former des noms propres en Kabiyè. *Annales de l'Université de Lomé,
Séries Lettres XXI*, 2, 229-312.
- Kenstowicz, Michael. 1994. *Phonology in Generative Grammar*. USA, UK: Blackwell
Publishers Ltd.

- Kiparsky, Paul. 1982. From cyclic to lexical phonology. *The structure of phonological representations*, ed. Van den Hulst and N Smith. Foris, Dordrecht.
- Koelle, S. W. 1854. *Polyglotta Africana*. 1963 re-edition, Fourah Bay College. Sierra Leone. (Cited in Delord 1976.)
- Kozelka, Paul Robert. 1984. *The Development of National Languages: A Case Study of Language Planning in Togo (Africa; Ewe, Kabiye)*. Stanford University (PhD dissertation).
- Laniran, Yetunde Olabisi. 1992. *Intonation in tone languages: The phonetic implementation of tone in Yoruba*. Cornell University (PhD dissertation).
- Larson, T. J. 1985. Ecological and cultural setting of the Kabiye of northern Togo. *South African journal of Ethnology* 8, 3, 77–80.
- Larson, T. J. and Janet M. Reiss. 1985. *South African journal of Ethnology* 8, 3, 81–86. Pretoria: Anthropological Index, Royal Anthropological Institute, Harvard University.
- Larson, T. J. 1991. Six-day markets of the Kabiye of north Togo. *South African journal of Ethnology* 14, 4, 115–21.
- Larson, Thomas J. 1984. Kabiye fetish religion: a comparative study. *Anthropos*, 79, fasc. 1-3, 39–46.
- Lébiakaza, Kézié K. 1979. *Kabiye-Deutsch-Wörterbuch*, (kabiye-German Dictionary), Saarbrücken: Universität des Saarlandes (M.A. thesis).
- Lébiakaza, Kézié K. 1985. *Phonologie, Tonologie und Morphosyntax des Kabiye*.

- Inaugural Dissertation zur Erlangung des Doktorgrades der Philosophischen Fakultät der Universität des Saarlandes. Saarbrücken: Universität des Saarlandes (doctoral dissertation).
- Lébikaza, Kézié K. 1989. L'Alternance consonantique et le problème de l'interaction entre traits segmentaux et suprasegmentaux en kabyle [Consonant Alternation and the Problem of the Interaction between Segmental and Suprasegmental Features in Kabyle]. *Afrikanistische Arbeitspapiere* 19, 147–163.
- Lébikaza, Kézié K. 1991. Les Constructions possessives prédicatives et nominales en kabyle. [Predicative and Nominal Possessive Constructions in Kabyle] *The Journal of West African Languages* 21, 1, 91–103.
- Lébikaza, Kézié K. 1992. L'Interférence des termes de parente français dans le kabyle des locuteurs natifs en contact avec la langue française [The Interference of French Kinship Terms in the *Kabyle* of Native Speakers Who Have Contact with the French Language]. Cologne/Köln: *Afrikanistische Arbeitspapiere* 32, 65-84.
- Lébikaza, Kézié K. 1994. Les tons des verbes kabiyè dans les formes de l'inaccompli. In T. Geider and R. Kastenholz (eds.), *Sprachen und Sprachzeugnisse in Afrika. Eine Sammlung philologischer Beiträge*, 263–279, Wilhelm J.G. Möhlig zum 60. Geburtstag zugeeignet. Köln: Rüdiger Köppe Verlag.
- Lébikaza, Kézié K. 1996. L'Aspect, la référence temporelle et le processus de grammaticalisation dans les langues du gurunsi oriental (*kabiye*, tem, lambda,

- dilo). [Aspect, Temporal Reference, and the Grammaticalization Process in Eastern Grusi Languages (*Kabiye*, Tem, Lamba, Dilo)]. *Afrika und Uebersee* 79, 1, 37–56.
- Lébikaza, Kézié K. 1996/1997. Les Locatifs relationnels en *kabiye*: leurs propriétés sémantiques et Morphosyntaxiques. [Relational Locatives in Kabiye: their Semantic and Morphosyntactic Properties] *The Journal of West African Languages* 26, 1, 103–119.
- Lébikaza, Kézié K. 1998. Les verbes à argument prééminents et argument symétriques, et la forme stimuli-passive en *kabiye*. *Gur Papers / Cahiers Voltaïques* 3, 63–76.
- Lébikaza, Kézié Koyenzi. 1998. The item NA, a multifunctional syntactic relator. *Annales de l'Université du Bénin - Séries Lettres XVIII*, 51–71.
- Lébikaza, Kézié K. 1999. *Grammaire kabiye: une analyse systématique - phonologie, tonologie et morphosyntaxe*. Köln: Rüdige Köppe Verlag (Universität des Saarlandes doctoral dissertation, 1985).
- Lébikaza, Kézié K. 2000. Les contraintes exercées par les propriétés sémantiques des verbes dans la dérivation et au niveau des catégories TAM. *Gur Papers / Cahiers Voltaïques* 5, 103–114.
- Lébikaza, Kézié K. 2003. La Politique Des Langues Au Togo Au Temps de Westermann et Aujourd'Hui. In A. P. Oloukpona-Yinnon, and J. Riesz Ed., *Plumes Allemandes Biographies Et Autobiographies Africaines (Afrikaner erzählen ihr Leben)*, 71–86. Lomé: Presses De L'UL.
- Lébikaza, Kézié K. ed. 2003. Réanalyse: le trait locatif latent dans les substantifs et ses

- implications sématico-syntaxiques. *Actes du 3e Congrès Mondial de Linguistique Africaine, Lomé 2000*, 177–188, K. Kézié Lébikaza Ed. Cologne / Köln: Rüdige Köppe Verlag.
- Lébikaza, Kézié K. 2005. Deictic categories in particles and demonstratives in three Gur languages. In Voeltz Erhard F.K. (ed.) *Typological Studies in Language Studies in African Linguistic Typology* 64, 229–249. Amsterdam, Philadelphia: Benjamins.
- Lewis, M Paul (ed.). 2009. *Ethnologue: Languages of the World, Sixteenth edition*. Dallas, Tex.: SIL International.
- Manessy, Gabriel. 1979. *Contribution à la classification généalogique des langues voltaïques*. Paris : SELAF.
- Manessy, Gabriel. 1981. Les langues voltaïques. In Perrot Jean (ed.), *Les langues dans le monde ancien et moderne*, CNRS, Paris.
- Marmor, Thomas W. 1980. A comparison of Kabiye adult and child narrative discourse. M.A. thesis, The University of Texas at Arlington.
- Ménard, René. 1974. [Review] *Musique Kabiyé (Togo)* of R. Verdier and A-M de Lavilleon. *Yearbook of the International Folk Music Council* 6, p. 162.
- Merchant Goss, Nisha and Amanda R. Doran. 2003. Voicing stops in Kabiye. *MITWPL* 45, 131–145.
- Naden, Tony. 1989. Gur. In John Bendor-Samuel and Rhonda L. Hartell (eds.), *The Niger-Congo languages*, 140–168. Lanham: University Press of America.
- Odden, David. 1986. On the Role of the Obligatory Contour Principle in Phonological

- Theory. *Language* 62, 2, 353–383.
- Odden, David. 1995. Tone: African languages. In Goldsmith John A. ed., *The Handbook of Phonological Theory*, 444–475. Oxford: Basil Blackwell Ltd.
- Paaluki (Balouki), Teteehaki. 1995. *Lexique bilingue de l'enseignement des 1er et 2e degrés du Togo. Fascicule I*. Lomé : HAHO/ACCT.
- Padayodi, Cécile M. 2008. Kabiye. *Journal of the International Phonetic Association* 38, 2, 215–221.
- Padayodi, Mamalinani. 1997. *A Contrastive Analysis of Derivation in Kabiye and English Lexical Formation Processes*. M.A. thesis, Université de Lomé.
- Pierrehumbert, Janet B. and Beckman Mary E. 1988. Japanese Tones Structure. *Linguistics Inquiry Monograph Fifteen*, MIT Press.
- Pike, Kenneth L. 1948. *Tone languages a technique for determining the number and type of pitch contrasts in a language, with studies in tonemic substitution and fusion*. *Linguistics*, 4. Ann Arbor: University of Michigan.
- Piot, Charles D. 1993. Secrecy, Ambiguity, and the Everyday in Kabre Culture. *American Anthropologist*, New Series, 95, 2, 353-370.
- Piot, Charles. 1996. Of Slaves and the Gift: Kabre Sale of Kin during the Era of the Slave Trade. *The Journal of African History* 37, 1, 31–49.
- Pulleyblank, Douglas. 1986. *Tone in lexical phonology*. Dordrecht: Reidel (MIT PhD dissertation, 1983).
- Roberts, David. 2002. The tone classes of Kabiye verbs. Institut de Linguistique et de

- Phonétique Générale et Appliquées. Unpublished M.A. thesis [English translation from French], Université de la Sorbonne Nouvelle - Paris III.
- Roberts, David. 2003. Tone spreading in the kabiye associative noun phrase. *Gur Papers / Cahiers voltaïques* 6, 95–100.
- Roberts, David. 2003. [Untitled Review] (Kabiye Grammar: A Systematic Analysis-Phonology, Tonology, and Morphosyntax of Lébikaza, Kézie Koyenzi). *Journal of African Languages and Linguistics* 24, 2, 202–204.
- Roberts, David. 2003. La tonologie des préfixes de modalité en kabiyè. Post Master's Thesis ("DEA"), ILPGA, Université de la Sorbonne nouvelle - Paris III.
- Roberts, David. 2006. Double sens doubles consonnes. In *Ebe Laba? la revue semestrielle du Comité de Langue Nationale Kabiyè* 25, 17–19.
- Roberts, David. 2006. Une idée capitale pour traiter les tons! In *Ebe Laba? la revue semestrielle du Comité de Langue Nationale Kabiyè* 26, 18–21.
- Roberts, David. 2008. The two Kabiye orthographies: A sociolinguistic and linguistic comparison. *Written Language and Literacy* 11, 1, 49–72.
- Roberts, David. 2008. *L'orthographe du ton en Kabiye au banc d'essai*. doctoral dissertation, Institut National des Langues et Civilisations Orientales. Ecole doctorale Langues, littérature et sociétés orientales.
- Sedlak, Philip A. S. 1980. *Kabiye Grammar Handbook*. Peace Corps Language Handbook Series. The Experiment in International Living, Brattleboro, Vermont.
- Sedlak, Philip A. S. and Essogoye Jassor. 1980. *Kabiye*. The Experiment in International

- Living, Brattleboro, Vermont.
- Snider, Keith L. 1990. Tone in Proto-Guang Nouns. *African Languages and Cultures* 3, 1, 87–105.
- Snider, Keith L. 1998. Phonetic Realisation of Downstep in Bimoba. *Phonology* 15, 1, 77–101. Cambridge University Press.
- Snider, Keith. 1999. *The geometry and features of tone*. Dallas: SIL and the University of Texas at Arlington.
- Snider, Keith. 2007. Automatic and non-automatic downstep in Chumburung: an instrumental comparison. *The Journal of West African Languages* 34, 1, 105–114.
- Tchagbalè, Zakari. 1976. *Phonologie et tonologie du Tem*. Thèse de doctorat, Université de la Sorbonne Nouvelle, Paris III.
- Tchangai, Farara Simtona. 1983. *Kabiye Mau Paytu*. Lomé: D.I.F.O.P.
- Verdier, Raymond and Anne-Marie de Lavilleon. 1960. *Musique Kabiyé : Togo*. Ocora, LP - Ocora 76 . / 65 / 66 / 72, Togo.
- Verdier, R. 1967. *Contes kabiye* (en collaboration avec M. BASSARI), Doc. du Cerk.
- Verdier, R. 1975. Note sur le canicide chez les Kabiye du nord-Togo. *Systèmes de pensée en Afrique noire* 1, 129–36. Anthropological Index, Royal Anthropological Institute.
- Verdier, R. 1981. Malheurs de l'homme et mise a mort rituelle de l'animal domestique dans la société kabiye. *Systèmes de pensée en Afrique noire* 5, 155–73. Anthropological Index, Royal Anthropological Institute.
- Welmers, Wm. E. 1973. *African Language Structures*. Berkeley: University of

California Press.

Yip, Moira. 2002. *Tone*. Cambridge Textbooks in Linguistics, Cambridge University Press.

Zerbian, Sabine. 2006. High Tone Spread in the Sotho Verb. In *Selected Proceedings of the 35th Annual Conference on African Linguistics*, ed. John Mugane *et al.*, 147–157. Somerville, MA: Cascadilla Proceedings Project.

BIOGRAPHICAL INFORMATION

Cécile Mamalinani Padayodi received her PhD in Linguistics at The University of Texas at Arlington in 2010. She received her Master's degree (French "DEA") in Linguistics from the Université de Lomé (former Université du Bénin), Togo in 2002, her M.A. in English Linguistics in 1998 and BA in English major from the same university in 1993. Since 2002, Cécile has been living in the United States where she has been pursuing research interests in Phonology, Phonetics, Translation, and Interpretation. After her M.A., she worked as French-English translator for the international non-governmental organization PLAN INTERNATIONAL. She also taught Phonetics and Phonology at The University of Texas at Arlington. Her dissertation project on Kabiye started in 2004 under the auspices of the American Association of University Women (AAUW), allowing her to conduct a fieldwork in Togo in 2006. Cécile plans to continue her teaching of Linguistics and her bilingual Translation and Interpretation.