

A MATHEMATICAL MODEL FOR
SWINE FLU 2009 WITH
VACCINATION

by

IRFAN TURK

Presented to the Faculty of the Graduate School of
The University of Texas at Arlington in Partial Fulfillment
of the Requirements
for the Degree of

MASTER OF SCIENCE IN MATHEMATICS

THE UNIVERSITY OF TEXAS AT ARLINGTON

August 2011

Copyright © by Irfan Turk 2011

All Rights Reserved

ACKNOWLEDGEMENTS

I would like to first thank my supervising Professor Dr. Hristo Kojouharov for always having time for me, and for his guidance, help and encouragement. I would also like to thank Dr. Anuj Mubayi and Professor Benito Chen for their contributions to my thesis. I would also like to thank Professor Dr. Jianzhong Su for accepting to be one of my committee members.

I would also like to thank all my course teachers for their priceless dedication to my learning and for their open door policies.

July 18, 2011

ABSTRACT

A MATHEMATICAL MODEL FOR
SWINE FLU 2009 WITH
VACCINATION

Irfan Turk, M.S.

The University of Texas at Arlington, 2011

Supervising Professor: Hristo Kojouharov

H1N1 influenza is one of the deadliest diseases in human's history. Swine Flu 2009 is the same virus and it was named in 2009. Vaccination is one of the most common ways to control a disease. We offer a new vaccination model with recommendations from the US Centers for Disease Control and Prevention (CDC). The entire population is divided into 4 different age groups: one group with no vaccination, one group with 2 doses of vaccination, and two groups with 1 dose of vaccination. We establish that higher levels of vaccination lead to greater savings of life. We also consider the effects of vaccination on the economy by comparing the number of infected people to different vaccination rates. We also consider a special case for office workers and nursing home persons to look at the aspects of the above mentioned effects. A set of numerical simulations is also presented to show these outcomes.

TABLE OF CONTENTS

ACKNOWLEDGEMENTS	iii
ABSTRACT	iv
LIST OF ILLUSTRATIONS.....	vii
LIST OF TABLES	viii
Chapter	Page
1. INTRODUCTION.....	1
1.1 H1N1 as Influenza A	1
1.2 Vaccination.....	2
1.3 Cost Analysis.....	2
2. REVIEW OF PREVIOUS RESEARCH	3
3. MATHEMATICAL MODEL	6
3.1 Infants.....	6
3.2 Second Age Group.....	7
3.3 Third and Fourth Age Groups	9
4. STABILITY ANALYSIS.....	11
4.1 Stability Analysis	11
4.1.1 Stability Analysis of All Groups	11
4.1.2 Stability Analysis of 3 rd Age Groups.....	14
5. NUMERICAL SIMULATIONS.....	16
5.1 The Whole System.....	16
5.1.1 $R_0 \leq 1$ and $R_0 > 1$	16
5.1.2 Different Vaccination Rates	24
5.2 Group 3 as Office Workers and Nursing Home Persons	27

5.2.1 Different Basic Reproduction Numbers	28
5.2.2 Different Vaccination Rates	30
6. COST ANALYSIS.....	35
6.1 Trapezoid Rule	35
6.2 Cost.....	35
6.3 Cost Analysis.....	36
7. DISCUSSION AND CONCLUSIONS.....	38
REFERENCES.....	40
BIOGRAPHICAL INFORMATION	42

LIST OF ILLUSTRATIONS

Figure	Page
1.1 Transmission diagram without age structure	3
2.1 The flow chart of SIRV model [12]	5
3.1 Diagram for infants	7
3.2 Flow chart of second age group	8
3.3 Diagram for the persons from 10 years to 64 years.....	9
5.1 First Age Group	17
5.2 Second Age Group.....	18
5.3 Third Age Group.....	19
5.4 Fourth Age Group.....	20
5.5 First Age Group with $R_0 > 1$	21
5.6 Second Age Group with $R_0 > 1$	22
5.7 Third Age Group with $R_0 > 1$	23
5.8 Fourth Age Group with $R_0 > 1$	24
5.9 Second Age Group.....	25
5.10 Third Age Group.....	26
5.11 Fourth Age Group.....	27
5.12 S V I R with $R_0=1$, and $v=0.1$	28
5.13 S V I R with $R_0>1$, and $v =0.1$	29
5.14 The same graph as figure 5.9 with general outlook	30
5.15 S V I R with $R_0<1$, and $v=0.8$	31
5.16 S V I R with $R_0>1$, and $v=0.8$	32
5.17 S V I R with $R_0>1$, and $v=0.8$	33

5.18 Graph of $I_1+I_2+I_3+I_4$ When $R_0=1.34$ - continued	34
5.19 Graph of confirmed and probable infected people from CDC	34
6.1 Cost Analysis with different vaccination rate.....	37

LIST OF TABLES

Table	Page
5.1 Model parameters with descriptions and values	16
6.1 Cost of Vaccination	35
6.2 Indirect Cost	35
6.3 When $R_0 < 1$	36
6.4 When $R_0 > 1$	36

CHAPTER 1

INTRODUCTION

1.1 H1N1 as Influenza A

H1N1 influenza type has had tremendous negative impacts on the human population. It was H1N1 influenza virus, also called Spanish Flu, which caused a disaster from June 1918 to December 1920. Between 50 and 100 million people died, which makes it one of the deadliest natural disasters on human's life [1]. The same virus H1N1 appeared more recently in Mexico City on 18 March 2009. Later, the Centers for Disease Control and Prevention (CDC) confirmed the first two cases of human infection with a pandemic influenza A (H1N1) virus in the United States on April 15, 2009 and April 17, 2009 [2].

According to the World Health Organization (WHO), the H1N1 influenza virus has now moved into the post-pandemic period. Nevertheless, the epidemic will continue locally in the world. Since the beginning of appearance of H1N1, it has spread to almost all the world. Even though our immune systems have produced memory cells to that or new virus of the influenza, there were still some countries such as India and New Zealand in late 2010 that were having severe levels of influenza H1N1 [3].

The cases that appeared in the United States from March 1, 2009 to May 5, 2009 are considered and studied in this work with a new vaccination model.

It is expected that H1N1 will keep up for many years; and the seasons of influenza can highly vary from time to time. The risk of getting the virus for younger generation is higher. And because of that, we need to maintain the precautions for the severity of the situations besides finding ways to control the outbreak.

Vaccination is the most effective way to control the disease. To get the disease under control, we need to apply a vaccination model to recover people from the disease, to apply

different doses of the vaccine to different age groups, as it is recommended by CDC, and to get an economical benefit.

1.2 Vaccination

Influenza immunization is the most effective preventive measure for reducing influenza related sicknesses [4]. In the United States, current recommendations for the use of influenza vaccines encourage all the people to receive vaccination [5].

In our model, we consider four age groups: [0, 6 months], (6 months, 9years], [10years, 64 years], and [65 years+). Infants younger than 6 months of age are too young to get any influenza vaccine [6]. Unlike most of the models [4,11,17,18], we ignore the vaccination for this group based on this data. For the children who are 6 months through 9 years of age, two doses of the vaccine are recommended as the usage is approved by The U.S. Food and Drug Administration (FDA) according to CDC. Because of this fact, for the second age group, 2 doses of vaccines are considered. Finally, for persons 10 years of age and older, 1 dose is considered in our model.

It is recommended to vaccinate all age groups, except infants, for the target region, or country just one time in general. The second age group is vaccinated with 2 doses by taking 4 weeks break between doses. It is also recommended to vaccinate the target age groups by subgroups such as families, schools, etc [7].

1.3 Cost Analysis

Influenza is the third cause of death in the advanced economy countries, preceded by only HIV, and tuberculosis. To see the big picture, we will take a look at the impact of the outbreak in terms of the economical aspect. We will examine the influence of direct and indirect cost of vaccination to the economy. The net economical benefit is calculated as well [9].

CHAPTER 2

REVIEW OF PREVIOUS RESEARCH

Many models for the spread of infectious diseases, such as, MSEIR, MSEIRS, SEIR, SEIRS, SIR, SIRS, SEI, SEIS, SI, and SIS, have been analyzed mathematically and applied to specific diseases [8]. With vaccination, several types of models have been studied as well such as XSLIJV, SVITR, SVIRS, SIRV, SEIRWRW, SAIV1V2, and SIV [10,13,14,15,16]. There are other vaccination models for influenza A, but since they are analyzed without mathematical equations and variables, we are not considering them here.

In SAIV1V2 model, the population is divided into susceptible (S), asymptotically infected (A), symptomatically infected (I), vaccinated with a single dose (V1), and vaccinated with two doses (V2). No pre-existing immunity is assumed. Whoever gets vaccination (1 or 2 doses) remains susceptible to the disease since vaccination is not 100% effective. Waning of vaccine is ignored. In this type, vaccination begins early, when vaccine supply is limited. After that, the two-dose strategy could mostly lead to a larger reduction in the final size of the epidemic compared to single-dose vaccination [10].

In SEIRWRW model, 5 age groups are considered which are 0-9, 10-19, 20-39, 40-64, 65+ years of age people. The model is based on a classical SEIR model.

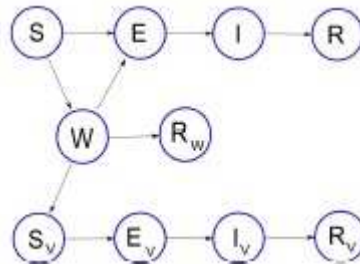

Figure 1.1: Transmission diagram without age structure [11]

In this type, vaccination is administered only to individuals in S until 60% target is reached. It is assumed that there is no pre-existing immunity in the first four age groups; and there is 20% reduction in susceptibility in the last age group. Whoever is vaccinated is moved to W class. It takes up to 14 days to produce antibodies for immune system after getting vaccine. During this time, infection is still possible. After 14 days, with rate probability, the immune people move into R_v class. If the vaccine is not effective, the people move into S_v , and follow the steps E_v , I_v , and R_v . There is no difference between the SEIR classes and $S_v E_v I_v R_v$ except the subscript v classes are vaccinated, but the vaccine did not work for them. And such individuals do not get vaccine again. Five different vaccination strategies are applied to compare such as uniform strategy, elderly first strategy, children first strategy, etc. If 60% coverage is targeted for each age group, the best scheduling scheme is the strategy that is prioritizing age groups depending on the number of social contacts. Beside this, the scheme can reduce the overall attack rate by 5-10% [11].

In the SIRV model, which is modified in this work, each individual is in one of the four stations. Total population is constant. The birth rate equals the death rate. Newborns are vaccinated at birth, at rate α , which is in $[0,1]$. $\beta SI/N$ is the rate that susceptible group become infective. This coefficient is multiplied by σ for the contacts between infective and vaccinated individuals. Susceptible individuals are vaccinated with rate constant ϕ , and vaccination wanes with a rate constant $\epsilon > 0$ in time. Recovery rate for infective individuals is constant, $\gamma > 0$. At the stage R, they have temporary immunity. Because of vaccine waning, members leave the R stage with a rate ν .

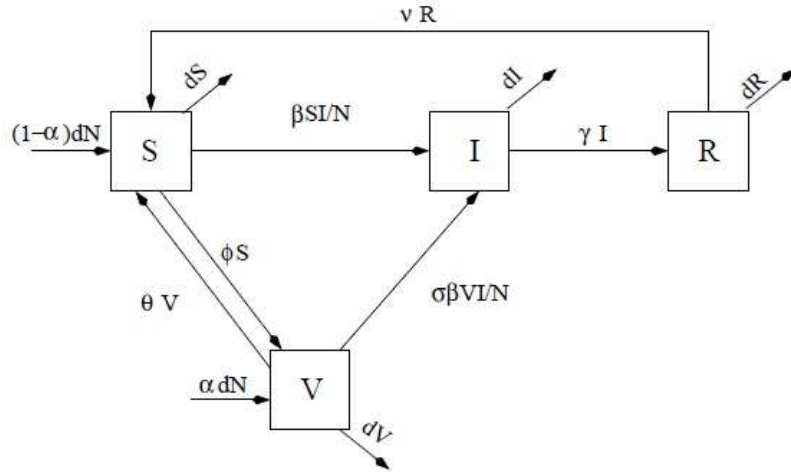

Figure 2.1: The flow chart of SIRV model [12]

In the model, R_{vac} is an important component which is the basic reproduction number as modified by vaccination. To get rid of the disease, it may not be sufficient to reduce R_{vac} below one.

In the model, global results are proved that alternative restrictions arise from alternative choices. The rate of vaccination of susceptible and the vaccine waning rate play an important role in the restrictions, whereas the vaccine efficacy, $1-\sigma$, and proportion of newborns vaccinated do not [12].

CHAPTER 3

MATHEMATICAL MODEL

We consider a model which has 4 age groups to see a more realistic situation with H1N1 and vaccination. For the model, we assume that persons get H1N1 influenza A vaccination, except the first group. After having vaccination, it takes up to 2 weeks for the immune system to develop antibodies and memory cells against the virus [10]. During that period, people can get infection also. But once the vaccination works for an individual, that individual has immunity from H1N1 for a lifetime. For the people who need and get the second dose, again we assume the same scenario as for the people who get vaccination at the beginning. The people can get the second dose after 4 weeks and during the first 14 days after that the body might get the infection as well. However, after 14 days from the second dose, the individual gets the necessary antibodies and memory cells which mean that the person is has immunity from H1N1 for a lifetime as well.

If the vaccination does not work, the individual does not take the vaccine again, and is a candidate for the virus. We assume further that there is no difference between an individual who did not get any shot and an individual who got the shot but the shot did not work for him/her.

We further assumed that the age groups are fixed due to the fact that the modeling time interval consists of 66 days. Total population of the system is preserved due to the simplifying assumption that birth rate equals to death rate and that the death rate is the same for all age groups.

3.1 Infants

For the group of infants, which are from 0 to 6 months, the model looks like a classical SIR model due to the lack of vaccination. It is recommended that no vaccination should be given to the infants for any type of influenza [6].

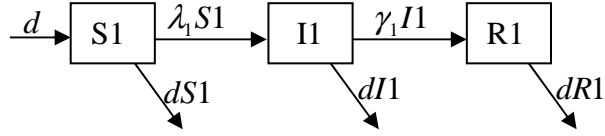

Figure 3.1: Diagram for infants

In figure 3.1, S1, I1, and R1 represent the groups of people for susceptible, infected, and removed respectively. λ_1 is the number which is a combination of contacts with different infected age groups. The number of newborn persons equals to the number of dead persons. d represents the newborns who come to this age group. β is the average number of contacts to be infected. Here, subscripts 1, 2, 3, and 4 correspond to the age groups 1, 2, 3, and 4 respectively.

$$\lambda_j = \sum_{k=1}^4 \left(\frac{\beta_k^j}{N_k} * I_k \right), \quad (1)$$

where N_k is the population of k^{th} group.

The rate γ is recovery constant rate. The system of differential equations with respect to time t is as below for the age group.

$$\begin{aligned} \frac{dS1}{dt} &= d - \lambda_1 S1 - dS1, \\ \frac{dI1}{dt} &= \lambda_1 S1 - \gamma_1 I1 - dI1, \\ \frac{dR1}{dt} &= \gamma_1 I1 - dR1. \end{aligned} \quad (2)$$

3.2 Second Age Group

In this age group, there are persons from 6 months to 9 years old. Two doses of vaccination are recommended by CDC for this group.

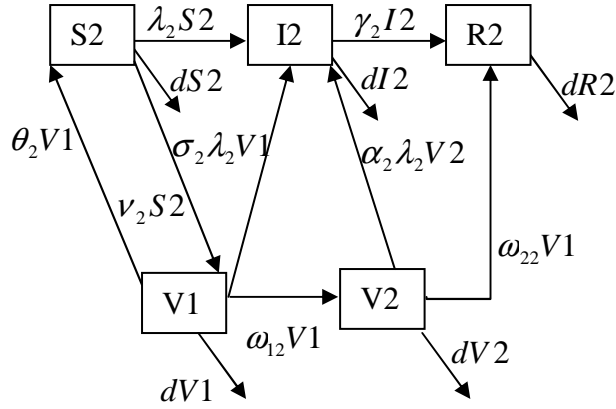

Figure 3.2: Flow chart of second age group.

In this group, an individual is vaccinated with a rate of ν . And that individual comes to the stage V1 from S2 group. After 14 days, it is possible to be infected with a rate of σ , as a result of contacting with infected individuals. If the vaccination does not work for an individual, that individual goes to S2 class again with a rate of θ , and does not get the vaccination again. After 28 days from the stage of V1, if the person is not infected, the person gets the second dose of vaccination. And that vaccination should be after 4 weeks of the first vaccination. From the first vaccination, the people go to the second vaccination stage with a rate of ω_{12} . Once the person is in the V2 stage, after getting second vaccination, again the same scenario happens. In the first 14 days, the individual can get infection, and go to I2 class with a rate of α as a result of the connection with I2 class. But if the person does not get infection after 14 days from the second vaccination, the person goes to recovery class, R2 with a rate of ω_{22} as a secured person from the outbreak lifetime. The equations from this age group are as follows.

$$\begin{aligned}
\frac{dS2}{dt} &= \theta_2 V1 - \lambda_2 S2 - \nu_2 S2 - dS2, \\
\frac{dV1}{dt} &= \nu_2 S2 - \sigma_2 \lambda_2 V1 - \theta_2 V1 - \omega_{12} V1 - dV1, \\
\frac{dI2}{dt} &= \lambda_2 S2 + \sigma_2 \lambda_2 V1 + \alpha_2 \lambda_2 V2 - \gamma_2 I2 - dI2, \\
\frac{dR2}{dt} &= \gamma_2 I2 + \omega_{22} V2 - dR2, \\
\frac{dV2}{dt} &= \omega_{12} V1 - \alpha_2 \lambda_2 V2 - \omega_{22} V2 - dV2.
\end{aligned} \tag{3}$$

3.3 Third and Fourth Age Groups

Third age group consists of the persons from 10 years of age to 64 years of age. One dose is given to these individuals.

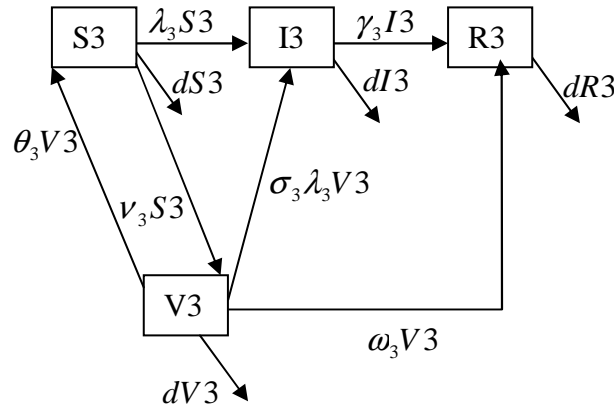

Figure 3.3: Diagram for the persons from 10 years to 64 years.

For the third age group, the persons get 1 dose of vaccination. The rest of the parameters are similar to the previous age group. After 14 days from the vaccination, if the person does not get infected, the person goes to the R3 stage with a rate of ω_3 for a lifetime from the virus. The equations for third age group are as follows.

$$\begin{aligned}
\frac{dS3}{dt} &= \theta_3 V3 - \lambda_3 S3 - \nu_3 S3 - dS3, \\
\frac{dV3}{dt} &= \nu_3 S3 - \sigma_3 \lambda_3 V3 - \theta_3 V3 - \omega_3 V3 - dV3, \\
\frac{dI3}{dt} &= \lambda_3 S3 + \sigma_3 \lambda_3 V3 - \gamma_3 I3 - dI3, \\
\frac{dR3}{dt} &= \gamma_3 I3 + \omega_3 V3 - dR3.
\end{aligned} \tag{4}$$

For the 4th group, which consists of the persons 65 years of age and older, the model is the same as the third group except the contact rate to be infected. β is smaller in the fourth group than the third group. It is found that older people has little bit better immune system against the virus [12]. The equations for the 4th age group are as below.

$$\begin{aligned}
\frac{dS4}{dt} &= \theta_4 V4 - \lambda_4 S4 - \nu_4 S4 - dS4, \\
\frac{dV4}{dt} &= \nu_4 S4 - \sigma_4 \lambda_4 V4 - \theta_4 V4 - \omega_4 V4 - dV4, \\
\frac{dI4}{dt} &= \lambda_4 S4 + \sigma_4 \lambda_4 V4 - \gamma_4 I4 - dI4, \\
\frac{dR4}{dt} &= \gamma_4 I4 + \omega_4 V4 - dR4.
\end{aligned} \tag{5}$$

CHAPTER 4
STABILITY ANALYSIS

4.1 Stability Analysis

In this chapter, we examine the stability of all age groups together for the disease free equilibrium (DFE), and the endemic equilibrium (EEP) points. We also separately examine the 3rd age group for both DFE and EEP points as well, which group can be regarded as office workers or nursing home persons that have no connection with the other age groups.

4.1.1. Stability Analysis of All Groups

If we combine all equations from (2), (3), (4), and (5), we get the whole system as in (6):

$$\begin{aligned}
\frac{dS1}{dt} &= d - \lambda_1 S1 - dS1, \\
\frac{dI1}{dt} &= \lambda_1 S1 - \gamma_1 I1 - dI1, \\
\frac{dR1}{dt} &= \gamma_1 I1 - dR1, \\
\frac{dS2}{dt} &= \theta_2 V1 - \lambda_2 S2 - v_2 S2 - dS2, \\
\frac{dV1}{dt} &= v_2 S2 - \sigma_2 \lambda_2 V1 - \theta_2 V1 - \omega_{12} V1 - dV1, \\
\frac{dI2}{dt} &= \lambda_2 S2 + \sigma_2 \lambda_2 V1 + \alpha_2 \lambda_2 V2 - \gamma_2 I2 - dI2, \\
\frac{dR2}{dt} &= \gamma_2 I2 + \omega_{22} V2 - dR2, \\
\frac{dV2}{dt} &= \omega_{12} V1 - \alpha_2 \lambda_2 V2 - \omega_{22} V2 - dV2, \\
\frac{dS3}{dt} &= \theta_3 V3 - \lambda_3 S3 - v_3 S3 - dS3, \\
\frac{dV3}{dt} &= v_3 S3 - \sigma_3 \lambda_3 V3 - \theta_3 V3 - \omega_3 V3 - dV3, \\
\frac{dI3}{dt} &= \lambda_3 S3 + \sigma_3 \lambda_3 V3 - \gamma_3 I3 - dI3, \\
\frac{dR3}{dt} &= \gamma_3 I3 + \omega_3 V3 - dR3, \\
\frac{dS4}{dt} &= \theta_4 V4 - \lambda_4 S4 - v_4 S4 - dS4, \\
\frac{dV4}{dt} &= v_4 S4 - \sigma_4 \lambda_4 V4 - \theta_4 V4 - \omega_4 V4 - dV4, \\
\frac{dI4}{dt} &= \lambda_4 S4 + \sigma_4 \lambda_4 V4 - \gamma_4 I4 - dI4, \\
\frac{dR4}{dt} &= \gamma_4 I4 + \omega_4 V4 - dR4.
\end{aligned} \tag{6}$$

The Jacobean matrix for the system is $J(\bar{x}) = \left[\frac{\partial RHS_i}{\partial x_j} \right]_{i,j}$, where

$\bar{x} = (S1, I1, R1, S2, V1, I2, R2, V2, S3, V3, I3, R3, S4, V4, I4, R4)$, and RHS is the vector of right hand side functions in system (6).

For DFE, we have $(1,0,0,0,\dots,0)$ which satisfies the system (6). Here, all eigenvalues of the matrix are negatives except $\beta_1^1 - d - \gamma_1$.

Here, we encounter a number which is known as basic reproduction number, R_0 . R_0 is the average number of infections caused by one infective without vaccination [12]:

$$R_0 = \frac{\beta_1^1}{\gamma_1 + d}. \quad (7)$$

Therefore, in (7), if $\beta_1^1 - d - \gamma_1 < 0$, which means that if $R_0 < 1$, then all eigenvalues are negative, and then DFE point is locally asymptotically stable. If $R_0 > 1$, then it is unstable.

For EEP, in (6) age groups of 2, 3, and 4 go to zero when time goes to infinity. Because there is no any inflow parameter in the 2nd, 3rd, and 4th age groups, in the long run their populations die. Only the population of first age group does not die. Still the sum of the all groups is preserved as well, and for EEP, we have only first age group, S1, I1, and R1 at the following values:

$$\begin{aligned} S1 &= \frac{1}{R_0}, \\ I1 &= \frac{d(R_0 - 1)}{\beta_1}, \\ R1 &= \frac{\gamma_1}{\beta_1}(R_0 - 1). \end{aligned} \quad (8)$$

Therefore, $EEP = (\frac{1}{R_0}, \frac{d}{\beta_1}(R_0 - 1), \frac{\gamma_1}{\beta_1}(R_0 - 1), 0, 0, 0, \dots, 0)$. In (8), $R_0 > 1$ for EEP, a positive I1 value.

We need to look at the system (2). And Because $S_1+I_1+R_1=1$, R_1 can be written as a combination of S_1 , and I_1 . The Jacobi matrix of the system is below.

$$J = \begin{bmatrix} -\beta_1 I_1 - d & -\beta_1 S_1 \\ \beta_1 I_1 & \beta_1 S_1 - (\gamma_1 + d) \end{bmatrix}, \text{ and } J(S_1, I_1) = \begin{bmatrix} -dR_0 & \frac{-\beta_1}{R_0} \\ d(R_0 - 1) & \frac{\beta_1}{R_0} - (\gamma_1 + d) \end{bmatrix}.$$

Since characteristic polynomial of J matrix is $\lambda^2 - Tr(J)\lambda + \det(J)$, and $\lambda_{1,2} = \frac{1}{2}(Tr(J) \mp \sqrt{Tr^2(J) - 4\det(J)})$, eigenvalues are negative. Therefore EEP is locally asymptotically stable in the case of $R_0 > 1$.

4.1.2. Stability Analysis of 3rd Age Group

In this age group, we assumed that there is no contact with other age groups. Therefore, our equations are just as in (4) with all parameters constant and independent of the other age groups:

$$\begin{aligned} \frac{dS_3}{dt} &= \theta_3 V_3 - \beta_3 I_3 S_3 - \nu_3 S_3 - dS_3, \\ \frac{dV_3}{dt} &= \nu_3 S_3 - \sigma_3 \beta_3 I_3 V_3 - \theta_3 V_3 - \omega_3 V_3 - dV_3, \\ \frac{dI_3}{dt} &= \beta_3 I_3 S_3 + \sigma_3 \beta_3 I_3 V_3 - \gamma_3 I_3 - dI_3, \\ \frac{dR_3}{dt} &= \gamma_3 I_3 + \omega_3 V_3 - dR_3. \end{aligned} \tag{9}$$

The DFE=(0,0,0,0) is locally asymptotically stable due to the fact that all eigenvalues are negative.

For EEP, where $I_3 > 0$, we have a condition from the 3rd equation in (9) that is

$$I_3(\beta_3 S_3 + \sigma_3 \beta_3 V_3 - \gamma_3 - d) = 0.$$

Here, $S_3 + \sigma_3 V_3$ is less than 1. Therefore, $\beta_3 > \gamma_3 + d$ should be. If $R_0 \leq 1$, then there is no EEP. If $R_0 > 1$, then there might be EEP with I_3 is different from zero.

From (9),

$$\begin{aligned} S_3 &= \frac{\theta_3}{\theta_3 + \sigma_3(v_3 + \beta_3 I_3 + d)} x \frac{(\gamma_3 + d)}{(\beta_3)}, \\ V_3 &= \frac{(v_3 + \beta_3 I_3 + d)}{\theta_3 + \sigma_3(v_3 + \beta_3 I_3 + d)} x \frac{(\gamma_3 + d)}{(\beta_3)}, \\ R_3 &= (\omega_3 \left(\frac{(v_3 + \beta_3 I_3 + d)}{\theta_3 + \sigma_3(v_3 + \beta_3 I_3 + d)} x \frac{(\gamma_3 + d)}{(\beta_3)} \right) + \gamma_3 I_3) / d, \\ I_3 &= I_3 > 0. \end{aligned} \tag{10}$$

By substituting (10) into (9), we get a quadratic equation to find possible I_3 values. Let

$Q(I_3) = A I_3^2 + B I_3 + C = 0$ where,

$$\begin{aligned} A &= \sigma_3 \beta_3^2, \\ B &= \beta_3 \omega_3 + \beta_3 d + \beta_3 \theta_3 + \beta_3 \sigma_3 v_3 + \beta_3 \sigma_3 d, \\ C &= \theta_3 d + \omega_3 v_3 + \omega_3 d + v_3 d + d^2. \end{aligned}$$

It is obvious that all A, B, and C values are positive due to the fact that all parameter values are positive. Therefore, both I_3 values are negatives.

$$I_{3_1} = \frac{-B - \sqrt{B^2 - 4AC}}{2A}, \quad I_{3_2} = \frac{-B + \sqrt{B^2 - 4AC}}{2A}.$$

Thus, there is no positive EEP as well, when $R_0 > 1$.

CHAPTER 5
NUMERICAL SIMULATIONS

5.1 The Whole System

As a first case, we consider the all groups together to see how different categories of the system behave.

All parameters, along with their values or parameter ranges, that are used in the numerical simulation are given below in table 5.1.

Table 5.1: Model parameters with descriptions and values.

Parameter	Description	Value or Range
β	Coefficient of transmitting disease	0.4/day
d	Average life span	1/75 years
γ	Recovery Removed rate	1/21 days
ν	Vaccination rate	0 to 1
σ	Rate of contacts between vaccinateds and infecteds	0.04
θ	Rate of unsuccessful vaccination	1/5*365
α	Rate of contacts between 2 nd vaccinateds and infecteds	0.02
ω_{12}	Rate of removed from 1 st vaccination to 2 nd shot	1/14
ω_{22}	Rate of removed from 2 nd vaccination to removal	1/20
ω_3	Rate of removed from 1 st vaccination to removal	1/21

All parameters are taken from the journals at the references. And they are equal to each other in different age groups unless it is noted. Vaccination rate is 0.1 for the 5.1.1 section.

5.1.1. $R_0 \leq 1$ and $R_0 > 1$

When $R_0 \leq 1$, we have graphs of 4 different age groups as below.

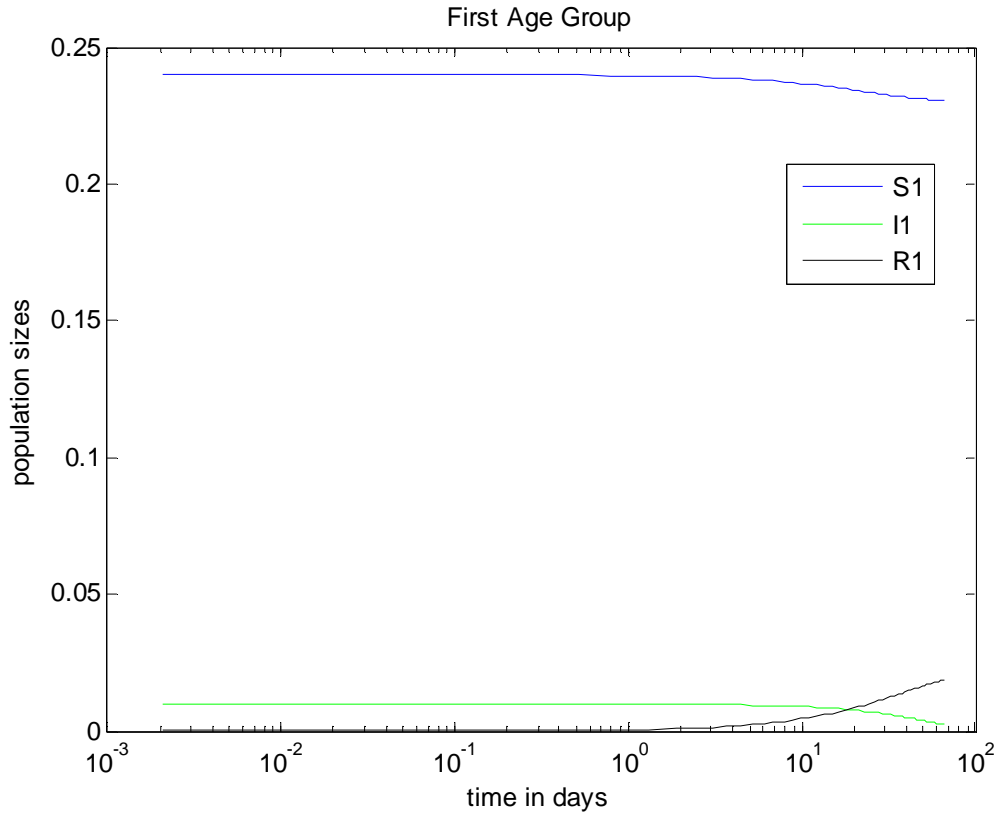

Figure 5.1: First Age Group

As initial values, we have $S1=0.24$, $I1=0.01$, and $R1=0$.

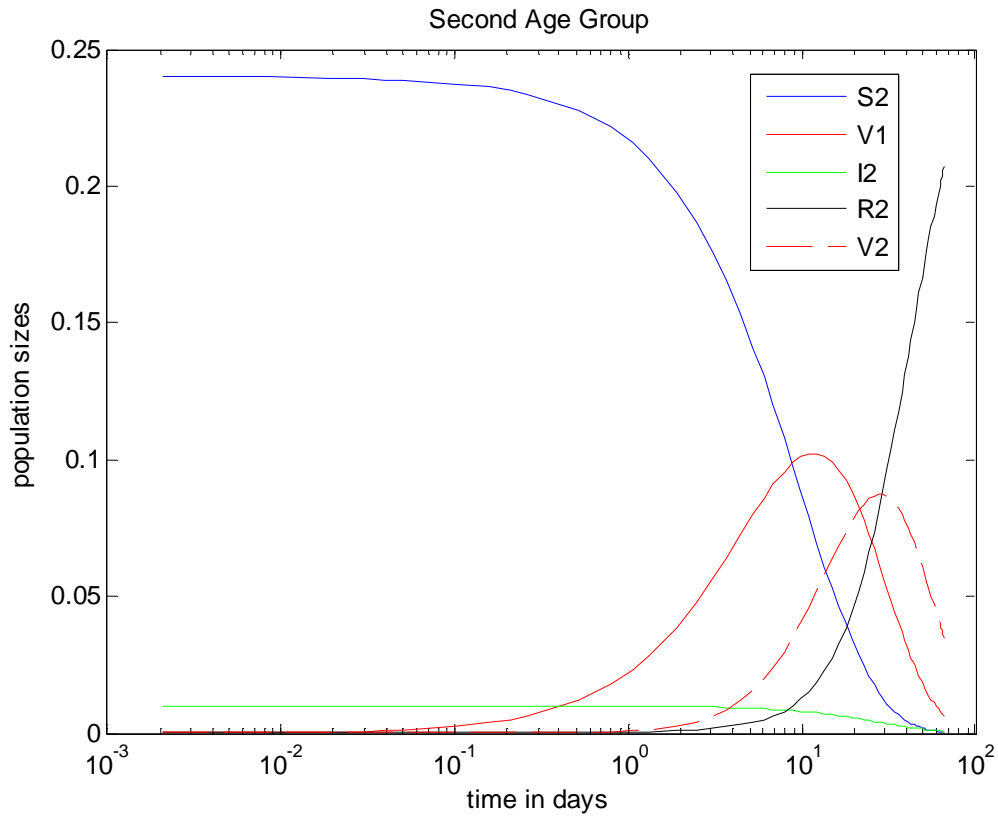

Figure 5.2: Second Age Group

As initial values, we have $S_2=0.24$, $V_1=0$, $I_2=0.01$, $R_2=0$, and $V_2=0$.

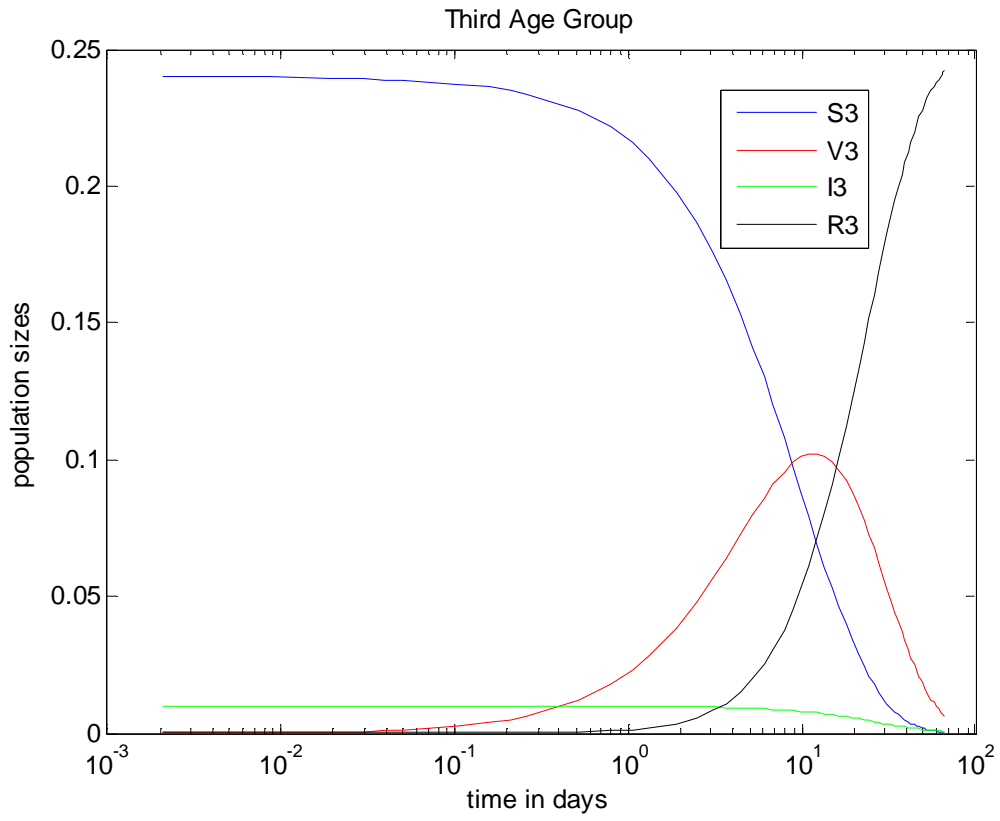

Figure 5.3: Third Age Group

As initial values, we have $S_3=0.24$, $V_3=0$, $I_3=0.01$, and $R_3=0$.

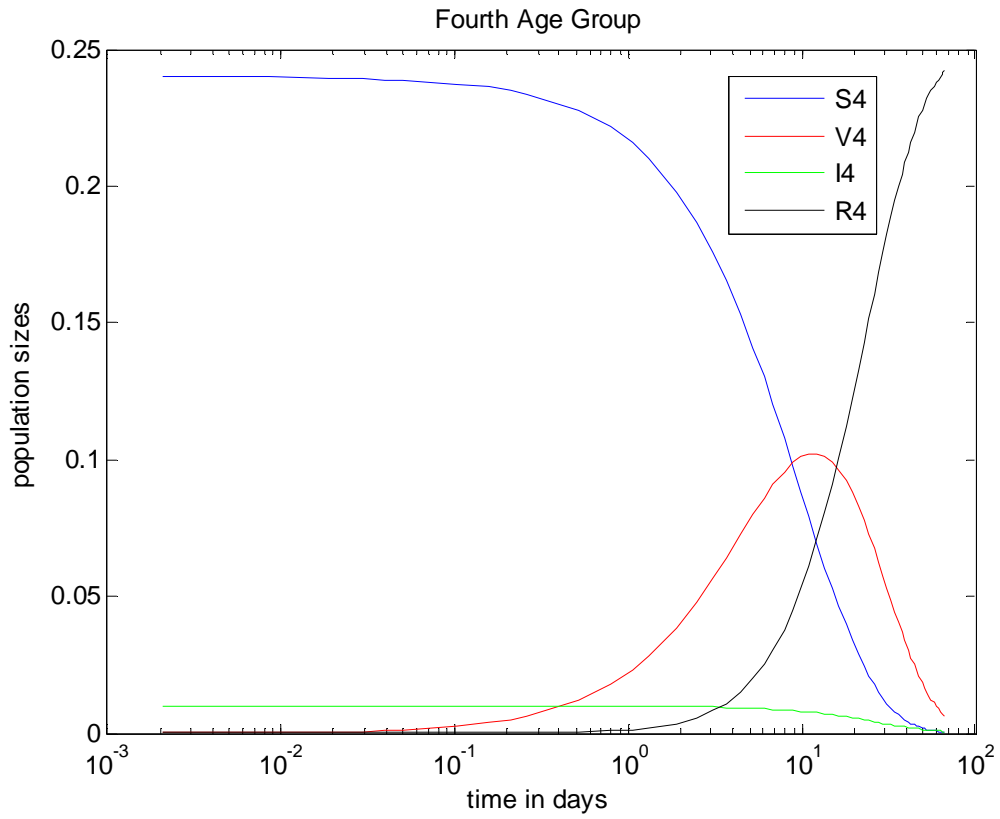

Figure 5.4: Fourth Age Group

As initial values, we have $S_4=0.24$, $V_4=0$, $I_4=0.01$, and $R_4=0$.

When $R_0 > 1$, with same initial values, we have the following graphs.

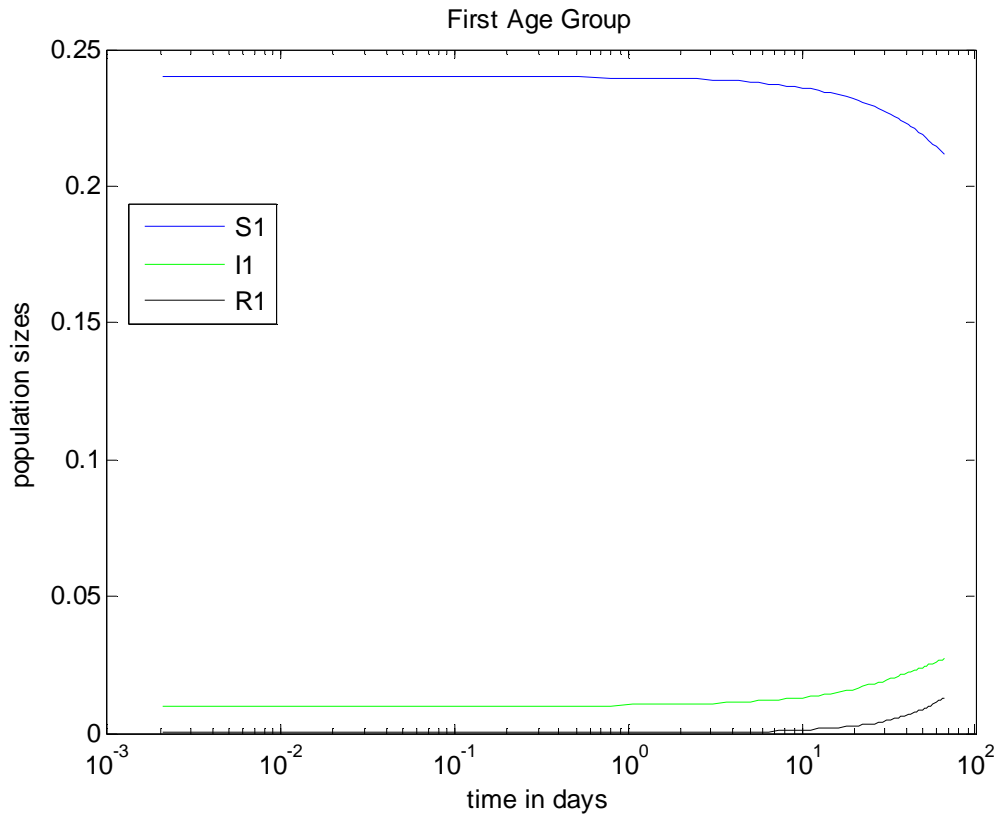

Figure 5.5: First Age Group with $R_0 > 1$

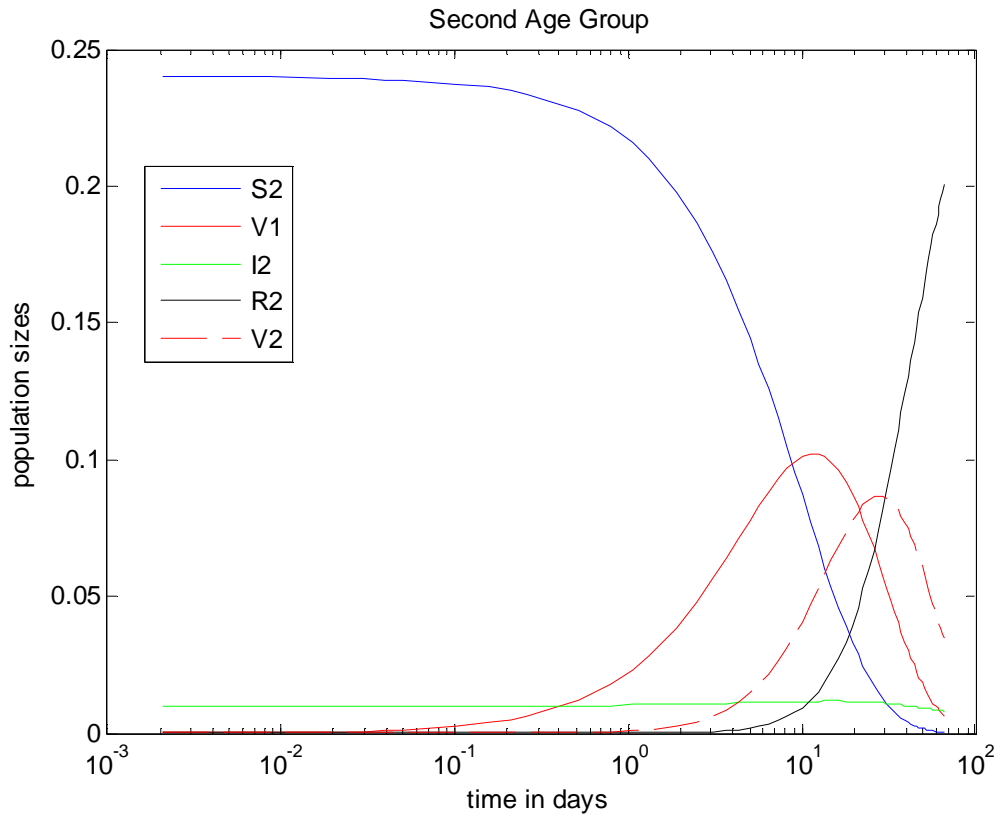

Figure 5.6: Second Age Group with $R_0 > 1$

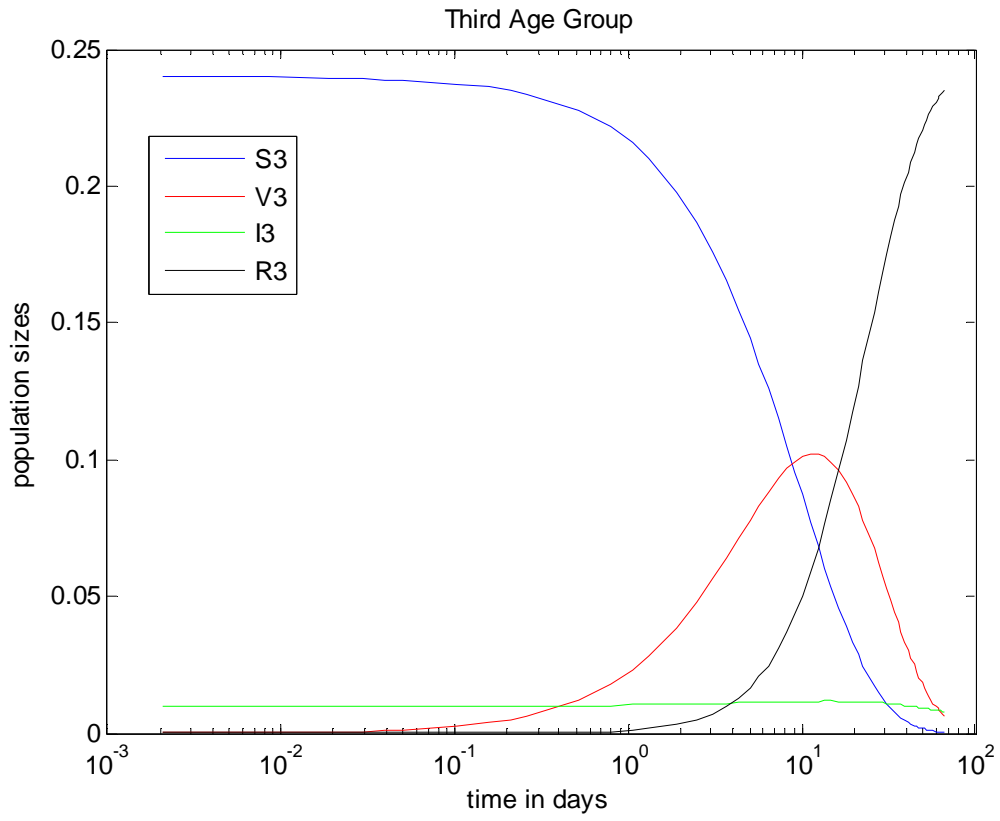

Figure 5.7: Third Age Group with $R_0 > 1$

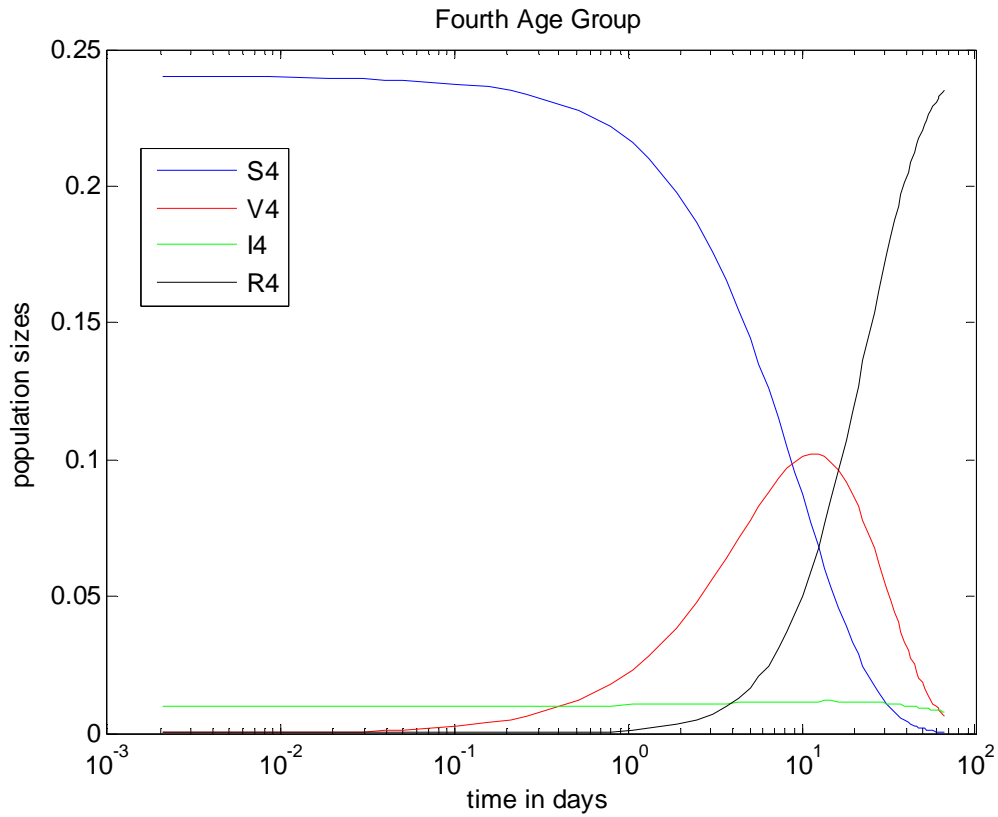

Figure 5.8: Fourth Age Group with $R_0 > 1$

5.1.2. Different Vaccination Rates

If the vaccination rate is increased to 0.7, we have changes in the graphs of 2nd, 3rd, and 4th groups. 1st group is not changed due to the fact that no vaccination is given to the group. In the graphs below, we have $R_0 < 1$.

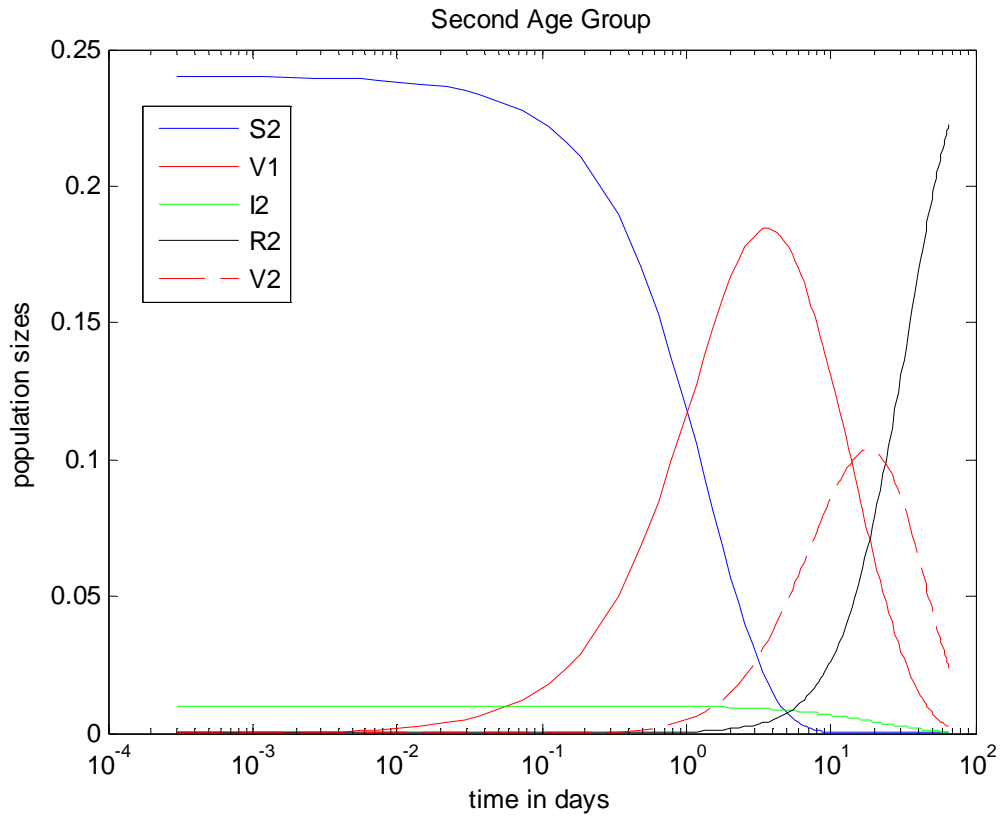

Figure 5.9: Second Age Group

As initial values, we have $S_2=0.24$, $V_1=0$, $I_2=0.01$, $R_2=0$, and $V_2=0$.

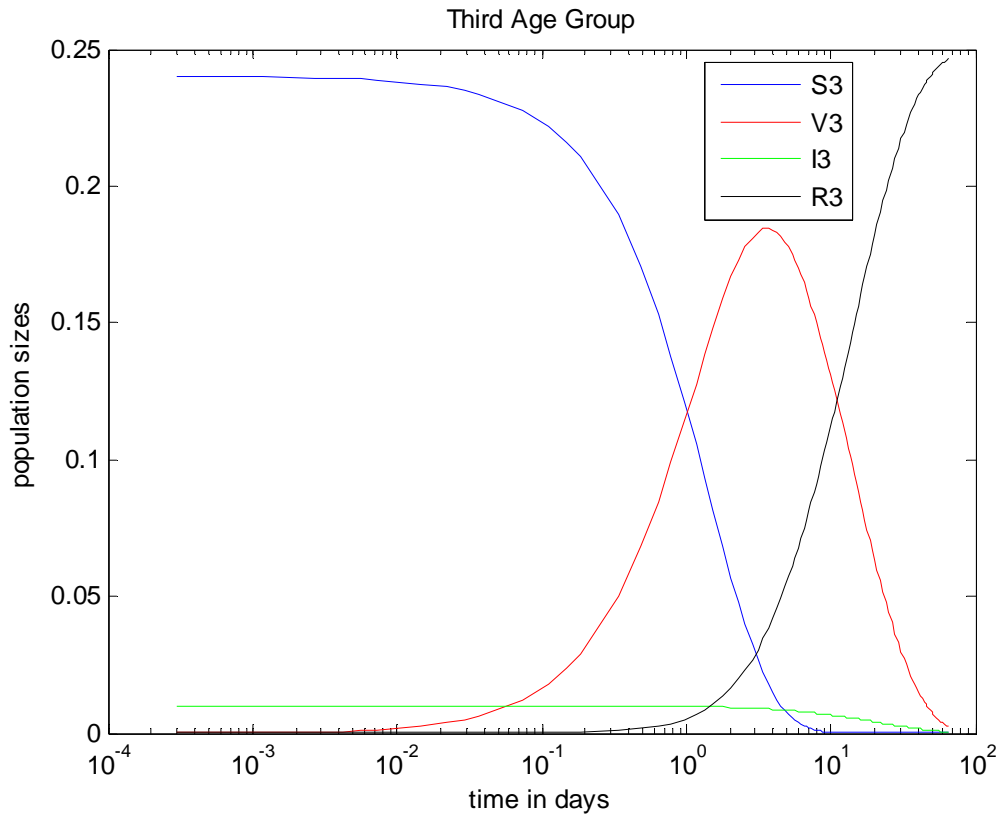

Figure 5.10: Third Age Group

As initial values, we have $S_3=0.24$, $V_3=0$, $I_3=0.01$, and $R_3=0$.

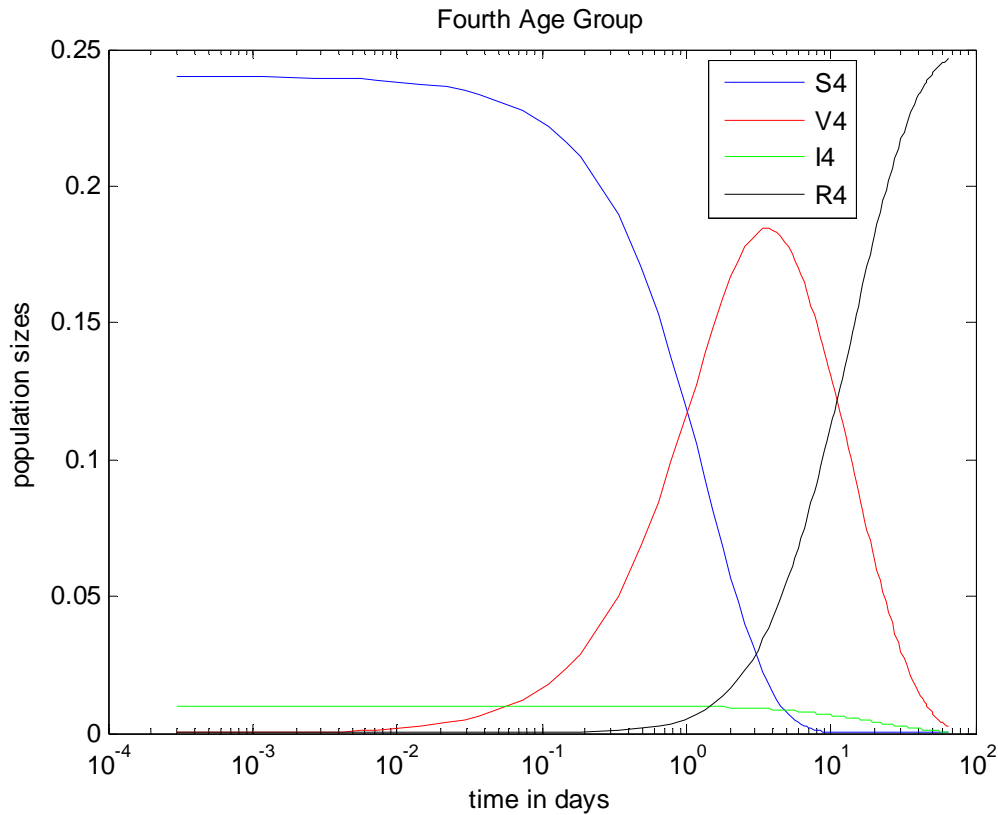

Figure 5.11: Fourth Age Group

As initial values, we have $S_4=0.24$, $V_4=0$, $I_4=0.01$, and $R_4=0$.

It is obvious that when $R_0 < 1$, recovered and removed people are increasing once we increase the vaccination rate. While $R_0 > 1$, again recovered and removed people are slightly increasing once we increase the vaccination rate. For example, when $v=0.1$, R_2 , R_3 , and R_4 reach the maximum values of 0.087, 0.235, and 0.235 respectively at the end of 66 days. While $v=0.7$, R_2 , R_3 , and R_4 reach the maximum values of 0.1035, 0.2414, and 0.2414 respectively at the end of 66 days.

5.2 Group 3 as Office Workers and Nursing Home Persons

For a specific age group which consists of only office workers, or only nursing home persons, we consider the system (9). In the groups, we assume that there is no connection between groups.

5.2.1. Different Basic Reproduction Numbers

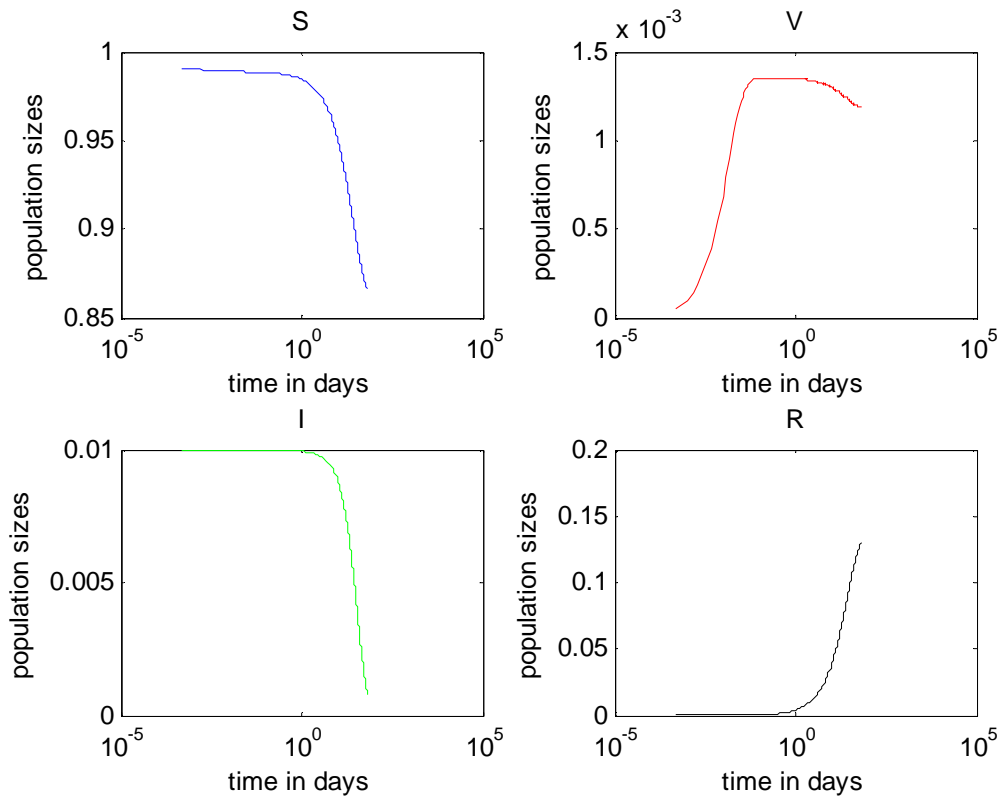

Figure 5.12: S V I R with $R_0=1$, and $\nu=0.1$.

Here, initial conditions are $S=0.99$, $I=0.01$, $V=0$, and $R=0$ as it is same in figure 5.13, 5.14, 5.15, and 5.16. When $R_0 < 1$, we have almost the same graph as in figure 5.12.

For figure 5.13 and 5.14, we have $R_0 > 1$.

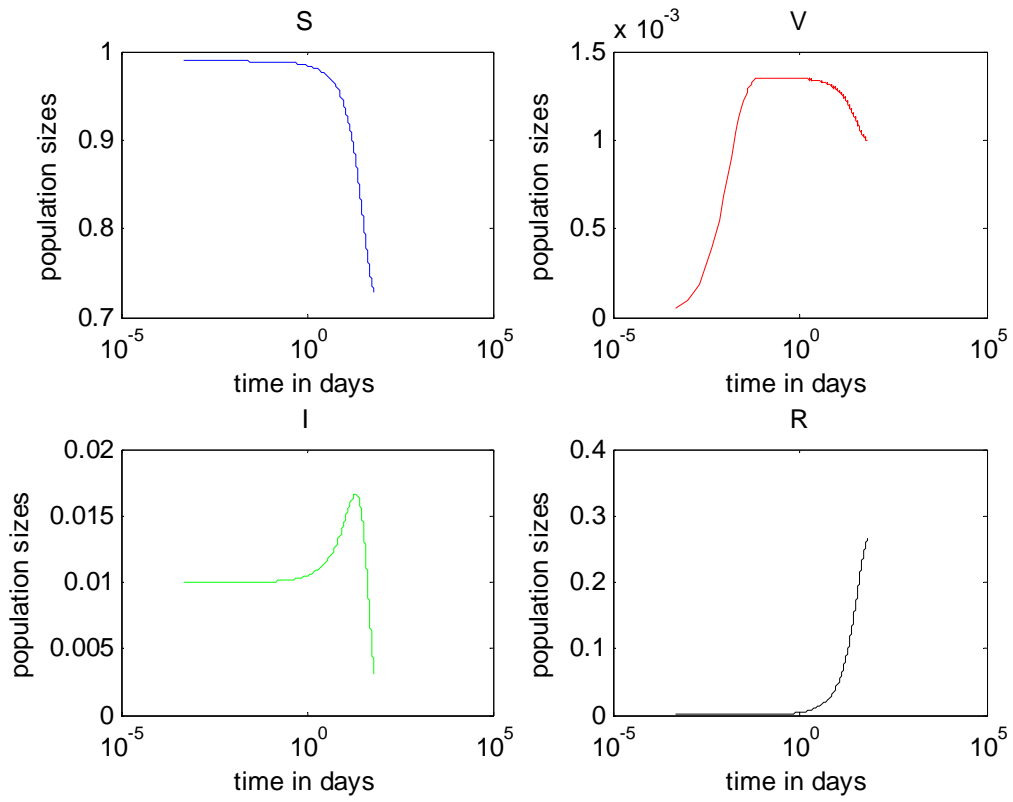

Figure 5.13: S V I R with $R_0 > 1$, and $\nu = 0.1$.

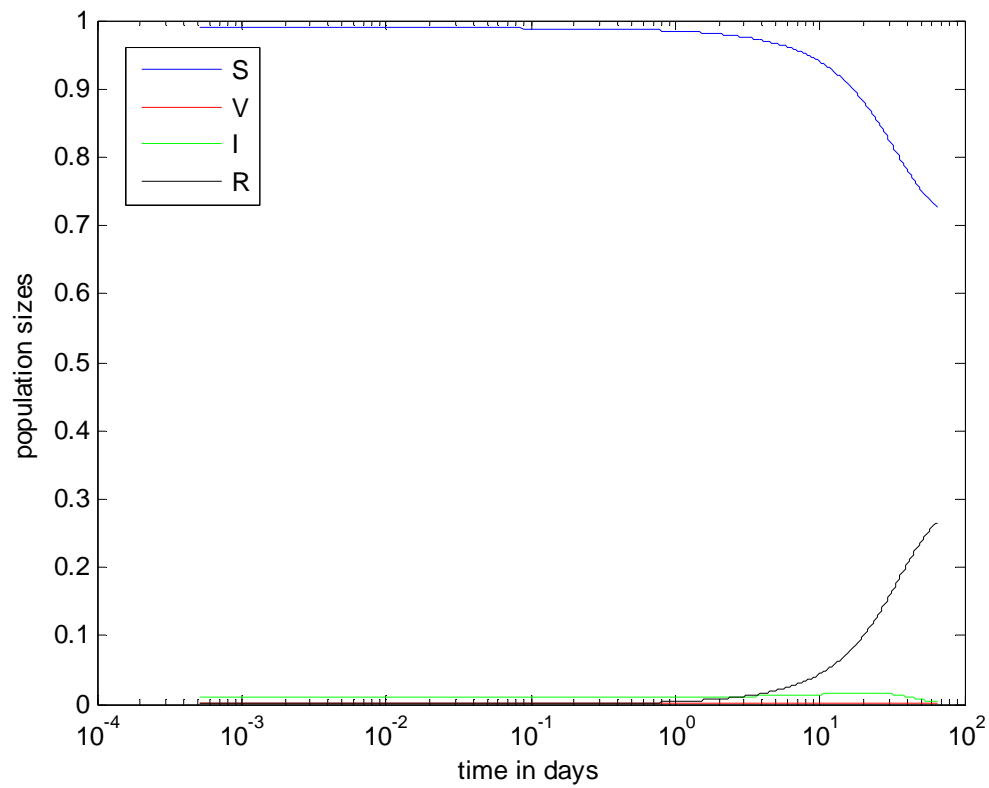

Figure 5.14: The same graph as figure 5.9 with general outlook.

5.2.2. Different Vaccination Rates

If we increase the vaccination rate as 0.8, we have the results as in figure 5.15 and

5.16.

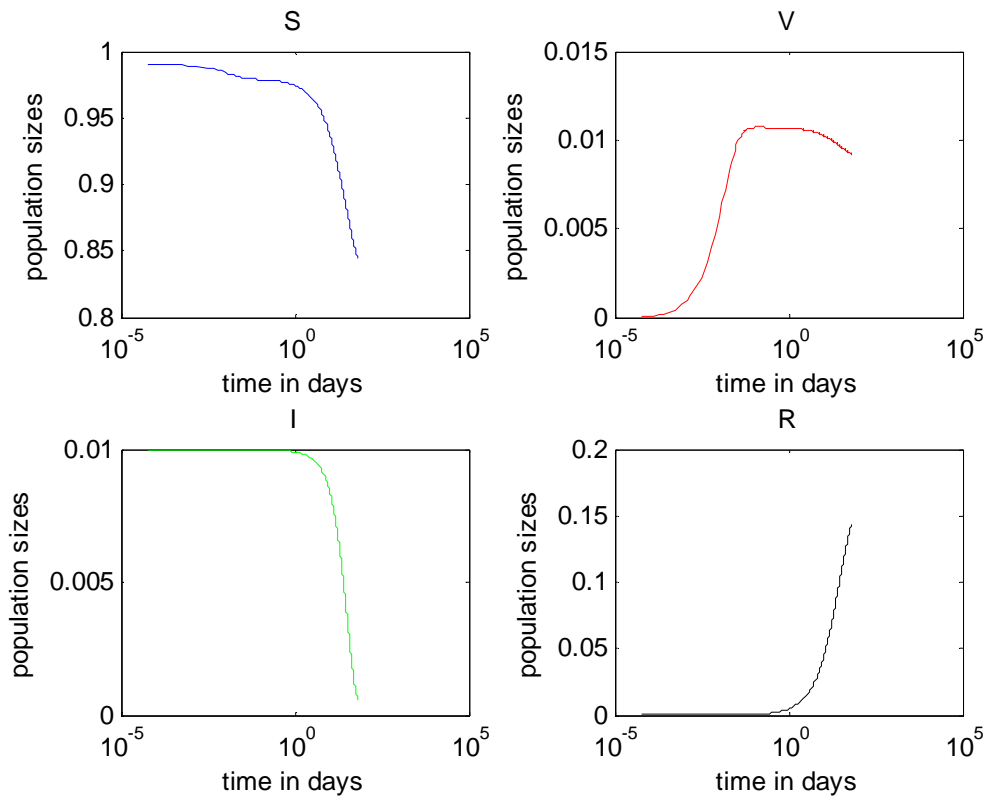

Figure 5.15: S V I R with $R_0 < 1$, and $\nu = 0.8$.

In the figure 5.15, infected people are not increased as it is in figure 5.13. And higher population in susceptible class exists in figure 5.15 comparing in figure 5.13.

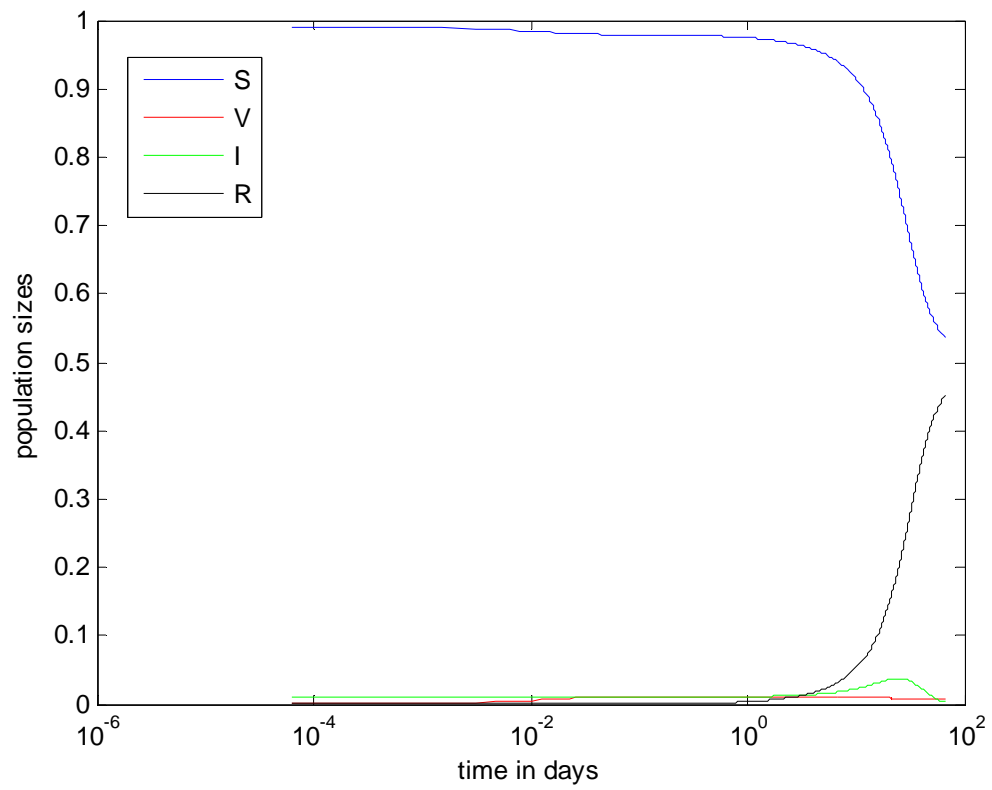

Figure 5.16: S V I R with $R_0 > 1$, and $\nu = 0.8$.

If the initial conditions are $S=1$, $V=0$, $I=0$, and $R=0$, we have the results as in figure

5.13.

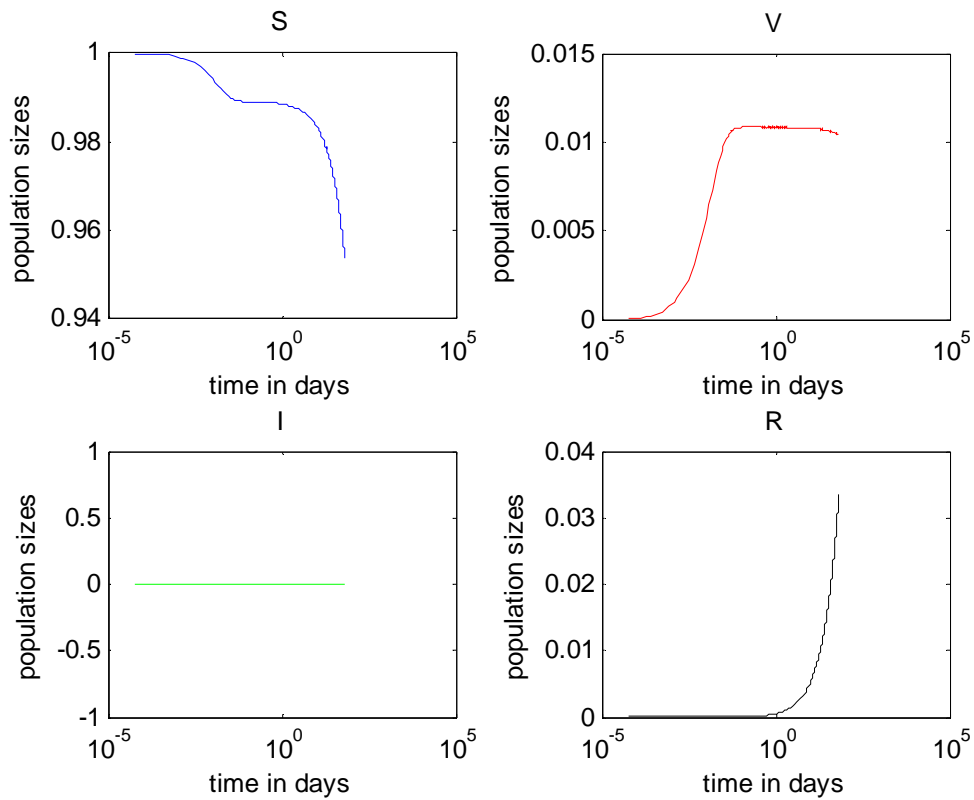

Figure 5.17: S V I R with $R_0 > 1$, and $\nu = 0.8$.

As it is seen from figure 5.17, the number of infected people is 0, and stable. If $R_0 < 1$, we see the same situation as well.

In the whole system, which is studied from March 1, 2009 to May 5, 2009 in the U.S.A., the graph of infected people is below in figure 5.18. If we compare it with the graph of CDC in figure 5.19, we can say that our simulation looks similar to the original data.

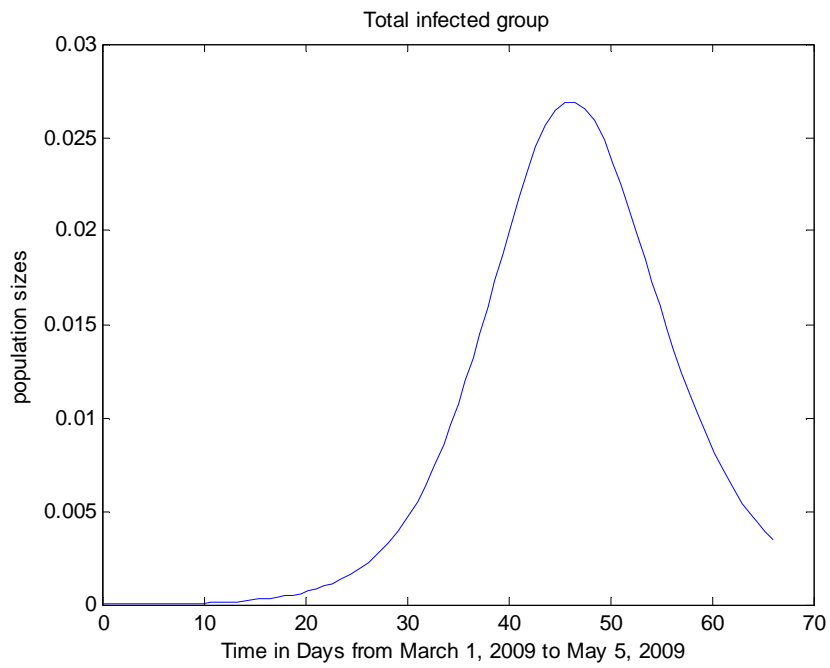

Figure 5.18: Graph of $I_1+I_2+I_3+I_4$ When $R_0=1.34$

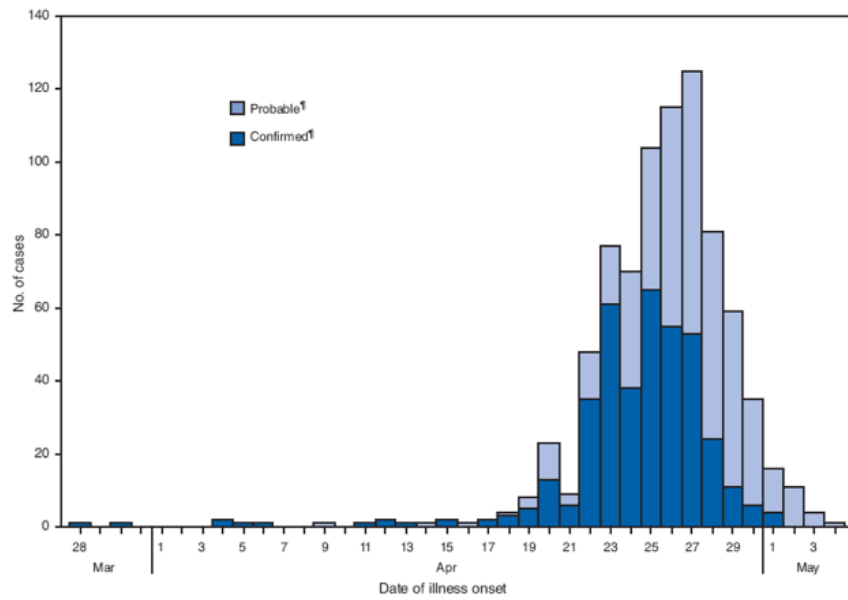

Figure 5.19: Graph of confirmed and probable infected people from CDC [14]

CHAPTER 6
 COST ANALYSIS
 6.1 Trapezoid Rule

In the 3rd age group, we find the area of the graph of I3 with respect to time t. In this way, the total numbers of sick-people days are calculated. We assume that 1 sick day means 1 person is absent for a work day. To find the area of the graph, the basic trapezoid rule is used [13], which for a function f(x) in the subinterval [x_i, x_{i+1}] can be written as:

$$\int_{x_i}^{x_{i+1}} f(x)dx \approx \frac{1}{2}(x_{i+1} - x_i)[f(x_i) + f(x_{i+1})].$$

Because we simulate the period March 1st - May 5th, 2009, the values of x_i are in [0, 66].

6.2 Cost

The cost calculations are done for 1000 persons. It is assumed that there exist 10 infected persons initially. There are direct and indirect costs for vaccinating people as it is shown in the table below. The cost amounts per person is taken from [9].

Table 6.1: Cost of Vaccination

Direct Cost	Per Person	Total
Vaccine	€ 4.77	€ 4,774.00
Nurse	€ 1.70	€ 1,700.00
Physician	€ 4.74	€ 4,735.00

Table 6.2: Indirect Cost

Lost working time(per hour)	€ 6.13	€ 6,131.00
	Total Direct and Indirect Cost	€ 17,340.00

The average hospitalizing time is taken as 6 days when a person gets the disease [2]. Therefore for a person, it costs €294.24 for 6 days for taking treatment. And it makes €294,240.00 for 1000 people if they become all sick and do not go to work.

6.3 Cost Analysis

We assumed that in an office environment, every person has a job. Two different costs are calculated depends on R_0 .

Table 6.3: When $R_0 < 1$

Vaccination rate	0	0.1	0.3	0.7	1
Total #of infected persons	418.1236	128.2123	93.6778	79.9011	76.3645
Total lost labor	€ 123,029	€ 37,725	€ 27,564	€ 23,510	€ 22,469
Total vaccination cost	€ 0	€ 1,734	€ 5,202	€ 12,138	€ 17,340
Total potential savings	€ 123,029	€ 35,991	€ 22,362	€ 11,372	€ 5,129

Table 6.4: When $R_0 > 1$

Vaccination rate	0	0.1	0.3	0.7	1
Total #of infected persons	1856.1	223.5292	145.9708	120.9322	114.998
Total lost labor	€ 546,139	€ 65,771	€ 42,950	€ 35,583	€ 33,837
Total vaccination cost	€ 0	€ 1,734	€ 5,202	€ 12,138	€ 17,340
Total potential savings	€ 546,139	€ 64,037	€ 37,748	€ 23,445	€ 16,497

As it is seen, there is a huge difference between vaccinating people in an office environment, and not vaccinating the workers. If the vaccination rate is 0, there is more economical damage. If everybody gets vaccination, there is less damage to the economy. What is very important, as we can see it in figure 6.1, is that even very little vaccination makes huge difference to decrease economical lost. There exists another factor that is related to saving life which is getting vaccination to get rid of the sickness and mortality. Therefore, we cannot emphasize enough how important the vaccination is. The benefit of living instead of dying is not studied in this work.

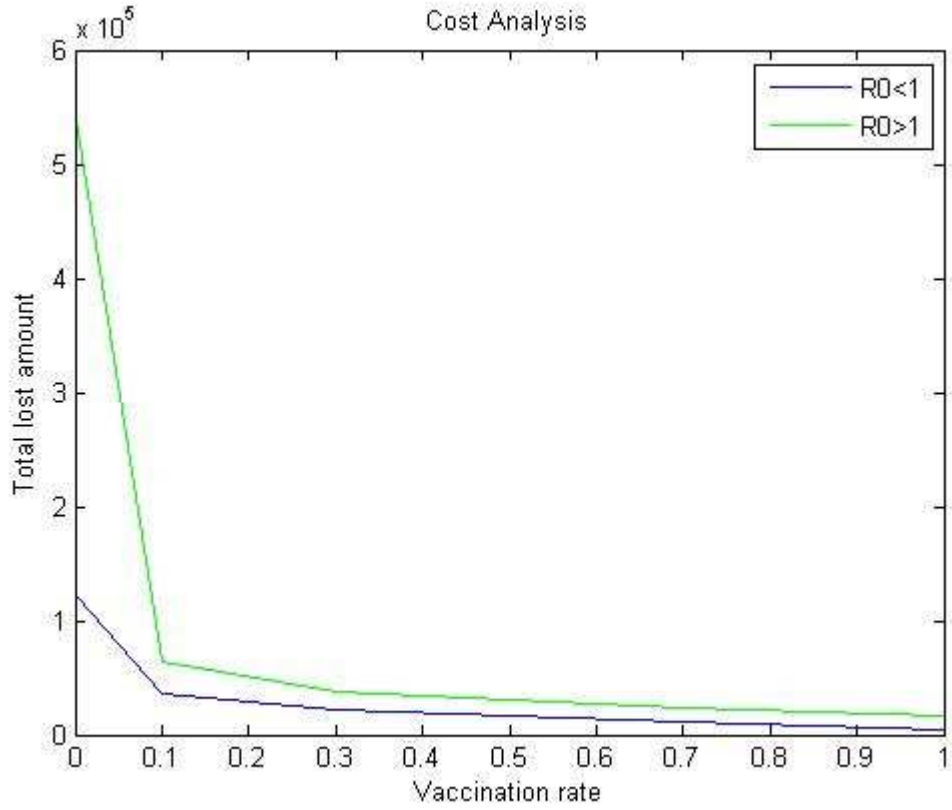

Figure 6.1 Cost Analysis with different vaccination rate

CHAPTER 7

DISCUSSION AND CONCLUSIONS

When $R_0 < 1$, DFE exists and stable. When $R_0 > 1$, DFE exists and it is unstable while EEP exists and stable.

In the simulation, If we increase the vaccination rate, the number of infected people is decreased in both cases when $R_0 > 1$, and $R_0 < 1$. If we change the initial conditions, the infected people stabilize to zero in positive initial condition, negative initial condition, or in zero condition.

In the model of all 4 age groups, when vaccination rate is 0.1, R class has most of the population except the first age group which does not have a vaccination. If we increase the vaccination to 0.8, population of vaccinated groups are increased at the beginning. But after a while, roughly more than 10 days in all age groups, except the first age group, again R class is increased, and has most of the population.

If we consider the class of nursing home persons, or office workers only, more or less, the scenario does not change as well. When vaccination rate is 0.1, S class has almost 87 % of all population, R class has almost 13%, and I, and V classes have almost 0% population after 66 days. Once we increase the time period to 365 days, S class has almost 83% while R class has almost 17%. Therefore, we can say that the population of R class is increased in time. When we increase the vaccination rate to 0.8, population of S class is around 85%, while R has almost 15 percentages in 66 days. If we increase the time period to 365 days, the population of S class is about 71.5 %, R class is about 26.6%, V is about 0.9 %, and I class is about 0 %. We can say that, time by time, population of R class is increased more once we increase the vaccination rate.

We can conclude that if we increase the vaccination rate, the numbers of recovered and removed persons are increased.

Also if we consider the cost of vaccination, more vaccination decreases the loss of labor costs caused due to the pandemic. To increase the economy in a disease case, we need to vaccinate people, even at small rates, in order to reduce the damage to the economy.

REFERENCES

- [1] http://en.wikipedia.org/wiki/1918_flu_pandemic
- [2] Seema Jain, Laurie Kamimoto, Anna M. Bramley, Ann M. Schmitz, Stephen R. Benoit, Janice Louie, David E. Sugerman, Jean K. Druckenmiller, Kathleen A. Ritger, Rashmi Chugh, Supriya Jasuja, Meredith Deutscher, Sanny Chen, John D. Walker, Jeffrey S. Duchin, Susan Lett, Susan Soliva, Eden V. Wells, David Swerdlow, Timothy M. Uyeki, Anthony E. Fiore, Sonja J. Olsen, Alicia M. Fry, Carolyn B. Bridges, Lyn Finelli, Hospitalized Patients with 2009 H1N1 Influenza in the United States, April-June 2009, The New England Journal of Medicine, 2009
- [3] http://www.who.int/csr/disease/swineflu/frequently_asked_questions/post_pandemic/en/index.html
- [4] Ashleigh R. Tuite, David N. Fishman, Jeffrey C. Kwong, Amy L. Greer, Optimal Pandemic Influenza Vaccine Allocation Strategies for the Canadian Population, Plos ONE, 2010
- [5] Kristin L. Nichol, Kate Tummers, Alanna Hoyer-Leitzel, Jennifer Marsh, Matt Moynihan, Steven McKelvey, Modeling Seasonal Influenza Outbreak in a Closed College Campus: Impact of Pre-Season Vaccination, In-Season Vaccination and Holiday/Breaks, Plos ONE, 2010
- [6] <http://www.cdc.gov/flu/protect/infantcare.htm>
- [7] D.J. Daley, J. Gani; Epidemic Modeling An Introduction, Cambridge University Press, 1999
- [8] Herbert W. Hethcote, The Mathematics of Infectious Diseases, Siam 2000

- [9] Giorgie L Colombo, Antonio Ferro, Marta Vinci, Maria Zordan, Giulio Serra, Cost benefit analysis of influenza vaccination in a public healthcare unit, 2006 Dove Medical Press Limited
- [10] Christopher S. Bowman, Julien Arino, Seyed M. Moghadas, Evaluation of Vaccination Strategies During Pandemic Outbreaks, Mathematical Biosciences and Engineering,2011
- [11] Diana H. Knipl, Gergely Rost, Modeling The Strategies for Age Specific Vaccination Scheduling During Influenza Pandemic Outbreaks, Mathematical Biosciences and Engineering,2011
- [12] Julien Arino, C. Connel McCluskey, And P. Van Den Driessche, Global Results for An Epidemic Model With Vaccination That Exhibits Backward Bifurcation, Siam 2003
- [13] Ward Cheney, David Kinziad, Numerical Mathematics and Computing, Sixth Edition, page:190, Thomson-Brooks/Cole, 2008.
- [14] <http://www.cdc.gov/mmwr/preview/mmwrhtml/mm5817a1.htm>

BIOGRAPHICAL INFORMATION

Irfan Turk finished his Bachelor of Science at Fatih University in Mathematics in 2002.

He worked as a mathematics teacher and administrator in private institutions in Turkey, and in public charter schools in Texas for 8 years.

His research interests are mathematical biology, scientific computing, and numerical analysis.