

INVESTIGATION OF POWER SYSTEM BLACKOUTS AND RELIABILITY
IMPROVEMENT FOR POWER DISTRIBUTION SYSTEMS

by

HUI ZHENG

Presented to the Faculty of the Graduate School of
The University of Texas at Arlington in Partial Fulfillment
of the Requirements
for the Degree of

DOCTOR OF PHILOSOPHY

THE UNIVERSITY OF TEXAS AT ARLINGTON

December 2007

ACKNOWLEDGEMENTS

Special thanks are reserved to my graduate advisor, Dr. Gou, for his advice, encouragement, and support throughout the development of this dissertation and my academic program.

Appreciation is also extended to Dr. W.J. Lee who shares his knowledge and suggestion with me.

I would like to send my special thanks to Prof. Weibiao Wu from Statistics Department at the University of Chicago, for his great assistance in the proofs of the theory proposed in my dissertation. In addition, I thank Mr. Yunzhi Cheng for his help about distributed computation in my research.

Finally, I would like to express my deep appreciation to my wife, Shu Xu, and the rest of my family for their affections, trust, and support. They have meant very much to me. I could not have successfully finished my Ph.D. program and this dissertation without them.

November 6, 2007

ABSTRACT

INVESTIGATION OF POWER SYSTEM BLACKOUTS AND RELIABILITY IMPROVEMENT FOR POWER DISTRIBUTION SYSTEMS

Publication No. _____

Hui Zheng, PhD.

The University of Texas at Arlington, 2007

Supervising Professor: Bei Gou

Modern power systems often consist of thousands of equipments, each of which may have an affect on the security of the system. The trend toward deregulation has forced utilities to operate their systems closer to security boundaries [1]. This has fueled the need of faster and more accurate methods of reliability and security assessment.

Power system reliability is defined as the probability that the power system will perform the function of delivering electric power to customers adequately on a continuous basis and with an acceptable quality [2]. Power system security assessment deals with the system's ability to continue to provide service in the event of an unforeseen contingency. Security evaluation has to encompass pre-disturbance conditions and transient performance of the system [3]. The definitions leave many

detail undefined and exemplifies the ambiguity in reliability analysis. They may include the unexpected loss of an important transmission circuit or a sudden change in a large load. Either of which could lead to service disruption on part or entire system. The goal of reliability and security assessment is to determine when service disruption is likely to occur and to take steps to reduce the risk.

The fact that power system operation is subject to an enormous number of random events that makes reliability and security analysis a rather complex issue. A complete analytical approach to a not so precisely defined problem is practically impossible. Monte Carlo simulation is often used as an alternative to analytical methods. The main advantages of Monte Carlo simulation include: (1) the ability to model very complex systems (like power systems) more accurately than analytical methods; (2) the model is easy to build and understand; and (3) the method can calculate both the expected value of reliability indices and their distributions [4]. The main disadvantage of Monte Carlo simulation is that it usually requires long simulation times in order to obtain accurate results. Due to the advance in computer technology, parallel computation is widely used for complicated calculation. Monte Carlo simulation is a typical application that is suitable for parallel computation. With this method, calculation time could be greatly reduced.

This dissertation analyzes the reliability of transmission and distribution system.

First, this dissertation investigates the general features of power system blackouts from the study of its mechanism through the employment of statistical and probability theory. The mechanism model of blackouts is presented, and the

deterministic and probabilistic factors involved in blackouts are introduced. The probability distribution of blackouts is derived based on the mechanism model. The implementation of sequential Monte Carlo Simulation is used to justify the validity of proposed theory of power system blackouts. Models of transient stability analysis and automatic generator control (AGC) are included; the model of hidden failures and normal reliability model are also described. The theoretical proofs are provided to justify the validity of the proposed distribution which is shown to be independent of the definition of blackouts and the modeling of power systems. Numerical results verify the validity of the derived probability distribution of the time to blackouts.

Second, Monte Carlo simulation is used to evaluate the quantitative impact of automatic switches on the reliability of power distribution systems. Based on the characteristics of the studied system's topology, the reliability model is developed for the implementation of Monte Carlo simulation. Reliability indices on each load are computed to obtain an overall reliability assessment of the system, and the sensitivity of the reliability indices to the location of automatic switches is also studied. Simulation results are used to illustrate the validity of the approach and are compared with the historical reliability records.

TABLE OF CONTENTS

| | |
|---|------|
| ACKNOWLEDGEMENTS..... | ii |
| ABSTRACT | iii |
| LIST OF ILLUSTRATIONS..... | ix |
| LIST OF TABLES..... | xi |
| Chapter | Page |
| 1. INTRODUCTION | 1 |
| 1.1 Background..... | 1 |
| 1.2 Motivations and Objectives | 3 |
| 1.3 Contributions | 5 |
| 1.4 Synopses of Chapters..... | 7 |
| 2. PROBABILITY DISTRIBUTION OF POWER SYSTEM BLACKOUTS.. | 9 |
| 2.1 Background..... | 9 |
| 2.2 Review of Happened Blackouts..... | 11 |
| 2.3 Mechanism of Cascading Failures or Blackouts | 13 |
| 2.3.1 Deterministic Factors..... | 13 |
| 2.3.2 Probabilistic Factors | 14 |
| 2.4 Statistical Distribution of Blackouts | 16 |
| 2.4.1 Preliminary Theory..... | 16 |
| 2.4.2 Distribution of PrimaryCause | 20 |

| | |
|--|----|
| 2.4.3 Distribution of Blackouts..... | 28 |
| 2.4.4 Discussion of the Proposed Distribution of Blackouts | 29 |
| 2.5 Summary | 31 |
| 3. POWER SYSTEMMODELING IN MONTE CARLO SIMULATION | 33 |
| 3.1 Power System Modeling..... | 33 |
| 3.1.1 Time Domain Simulation | 33 |
| 3.1.2 Automatic Generator Control (AGC) | 36 |
| 3.1.3 Hidden Failure | 40 |
| 3.2 Design of Sequential Monte Carlo Simulation..... | 41 |
| 3.2.1 Monte Carlo Simulation Model | 41 |
| 3.2.2 Flowchart of Sequential Monte Carlo Simulation | 43 |
| 4. SIMULATION RESULTS AND DATA ANALYSIS | 48 |
| 4.1 Justification of Theory of Power System Blackouts..... | 50 |
| 4.2 System Result and Data Analysis | 57 |
| 5. DISTRIBUTION SYSTEM RELIABILITY ANALYSIS..... | 63 |
| 5.1 Component Modeling | 65 |
| 5.2 System Modeling | 67 |
| 5.2.1 Component Reliability Parameters | 68 |
| 5.2.2 Failure Rates and Bathtub Curves | 69 |
| 5.2.3 Probability Distribution Functions | 71 |
| 5.2.4 Reliability Data..... | 72 |
| 5.3 Monte Carlo Simulation | 72 |

| | |
|--|----|
| 5.3.1 Radial Structure | 73 |
| 5.3.2 The Effect of Automated Switches..... | 76 |
| 5.4 Result and Analysis | 78 |
| 5.4.1 The SAIFI and SAIDI without Automated Switches | 78 |
| 5.4.2 The SAIFI and SAIDI with Automated Switches | 80 |
| 5.4.3 The Location of Automated Switches | 81 |
| 6. DISTRIBUTED COMPUTATION | 84 |
| 6.1 The Concept of Distributed Computation..... | 84 |
| 6.2 Applying Distributed Computation with Matlab..... | 84 |
| 7. SUMMARY AND CONCLUSIONS..... | 87 |
| 7.1 Summary and Conclusions | 87 |
| 7.2 Recommendation for Further Research..... | 89 |
| REFERENCES | 91 |
| BIOGRAPHICAL INFORMATION..... | 97 |

LIST OF ILLUSTRATIONS

| Figure | Page |
|---|------|
| 2.1 Mechanism of Cascading Failures or Blackouts | 15 |
| 3.1 Flowchart of governor and AGC procedures | 39 |
| 3.2 Probability of hidden failure | 43 |
| 3.3 Flowchart of sequential MCS for power system..... | 47 |
| 4.1 IEEE 24-bus system | 48 |
| 4.2 IEEE 118-bus system | 49 |
| 4.3 Justification of Theorem 1..... | 50 |
| 4.4 Justification of Theorem 2..... | 51 |
| 4.5 Justification of Theorem 3..... | 52 |
| 4.6 Justification of Theorem 4..... | 53 |
| 4.7 Comparison between the simulated results and theoretical results (primary Cause ²) | 54 |
| 4.8 Comparison between the simulated results and theoretical results (primary Cause ⁵) | 55 |
| 4.9 Comparison between the simulated blackout distribution and the theoretical distribution of blackouts (24-bus system)..... | 57 |
| 4.10 Comparison between the simulated blackout distribution and the theoretical distribution of blackouts (118-bus system)..... | 58 |
| 4.11 The P_i comparison of 24-bus system with 118-bus system..... | 60 |
| 4.12 Comparison between the simulated blackout distribution and the theoretical distribution of blackouts (118-bus system,1000samples)..... | 61 |

| | | |
|------|--|----|
| 4.13 | Comparison between the simulated blackout distribution (10,000samples) and the theoretical distribution of blackouts (parameters deduced from1000samples)..... | 62 |
| 5.1 | The Bathtub Curve | 70 |
| 5.2 | Component Failure Rate Curve versus Time | 71 |
| 5.3 | Example of a distribution feeder | 74 |
| 5.4 | Flowchart of upstream tracing process | 75 |
| 5.5 | Example of a distribution system | 77 |
| 5.6 | SAIFI of Different Customers on Haskell #1 | 79 |
| 5.7 | SAIDI of Different Customers on Haskell #1 | 80 |
| 5.8 | The SAIFI distribution of different customers | 82 |
| 5.9 | The SAIDI distribution of different customers | 82 |
| 6.1 | The basic distributed computing configuration..... | 85 |

LIST OF TABLES

| Table | Page |
|---|------|
| 2.1 Causes of Blackouts | 13 |
| 4.1 Parameters of different levels..... | 56 |
| 4.2 Comparison of 24-bus system with 118-bus system (10,000samples) | 59 |
| 5.1 Reliability Data of Distribution System | 72 |
| 5.2 Comparison of Historical Record with MCS Results | 79 |
| 5.3 Comparison of Effect of Automated Switches..... | 80 |
| 5.4 Comparison of different location of automated switch..... | 83 |
| 6.1 CPU time saved for power system blackout by distributed computation | 85 |
| 6.2 CPU time saved for distribution system reliability by distributed computation..... | 86 |

CHAPTER 1

INTRODUCTION

1.1 Background

With the trend of power markets throughout the world, modern power systems are suffering from insecure designs and operations. A number of blackouts have occurred in power grids worldwide in recent years.

In July and August 1996, two blackouts happened successively in the power grid of western America, which caused more than 4 million people in 11 states to loss power [6]. In 2003, a historically rare blackout was triggered in the United States and Canada, which cut power to over 50 million people; it was the largest blackout in the history of the US [7]. Within two months, in September, major blackouts occurred in the U.K., Denmark, Sweden and Italy. 57 million Italians were left in the dark because of complications in transmitting power from France into Switzerland and then into Italy [8]. In addition to inconvenience, blackouts are causing major economic losses. The problem will get worse until the entire transmission system that moves power from generating plants to neighborhood substations is overhauled. More high-voltage lines must be built to catch up with the rising demand imposed by ever more air conditioners, computers, and rechargeable gadgets. The continued occurrences of large scale blackouts in recent years draw the attention on the vulnerability of power systems.

Maintaining reliability is a complex enterprise that requires trained and skilled operators, sophisticated computers and communication networks, and careful planning and design. The North American Electric Reliability Council (NERC) and its ten Regional Reliability Councils have developed system operating and planning standards for ensuring the reliability of a transmission grid that are based on seven key concepts [9]:

- 1) Balance power generation and demand continuously
- 2) Balance reactive power supply and demand to maintain scheduled voltages
- 3) Monitor flows over transmission lines and other facilities to ensure that thermal limits are not exceeded.
- 4) Keep the system in a stable condition.
- 5) Operate the system so that it remains in a reliable condition even if a contingency occurs, such as the loss of a key generator or transmission facility (the “N-1 criterion”)
- 6) Plan, design, and maintain the system to operate reliably.
- 7) Prepare for emergencies.

Although these standards are executed, Blackouts are still unavoidable. There are several reasons for such a situation to exist.

Firstly, demand for electricity has increased steadily for decades, yet transmission lines that transport power from generation plants to customers have not been added or upgraded at the same pace. As witnessed in developed countries, including the USA, there has been a very slow expansion of the high voltage transmission grid during

recent decades due to stringent regulations put forward in response to environmental concerns. As a result, the grid has become more stressed, making it more prone to blackouts, which have risen in number and severity of power system blackouts [10].

Secondly, the lack of incentive in investing in new transmission facilities and the absence of effective cost recovery mechanisms for transmission investments has caused the serious problem of transmission inadequacy, especially in this market environment where generators respond to market opportunities by transferring larger quantity of power over longer distances more frequently [11].

Thirdly, in order to reduce power losses and deliver power efficiently from generation plants to customers located far away, progressively longer, higher-voltage lines were built. These high-voltage lines usually also allow neighboring utilities to link their grids. Such interconnectedness entails certain dangers however, including possibility that a shutdown in one section could rapidly propagate to others [8].

Since it is impossible to eliminate completely random faults and failures, it is necessary to measure security and perform analysis, then take measure to reduce the likelihood that disturbances degenerate into major blackouts.

1.2 Motivations and Objectives

A lot of factors are involved in power system blackouts. Ref. [12] summarized from the historic records and categorized them into deterministic and probabilistic factors. The deterministic factors are the causes defined by the physical operation limits/constraints; the probabilistic factors are the causes defined by the statistical characteristics of the system components. The tool to simulate deterministic factors

includes power flow analysis (PF), short current analysis (SC), automatic generator control (AGC), transient stability analysis (TS), etc. For the probabilistic factors, we need to consider the statistical characteristics.

There are many probabilistic factors such as line failures and human errors that may cause power system blackout. It has been observed that the protective system failure is the main probabilistic factors of large scale power system blackouts [13, 14]. It is known that undetected (or hidden) failures in protection systems commonly lead to multiple contingencies, which in turn can lead to power system blackouts.

Many studies have been conducted on power system reliability [15-21]. Because of the complexity of power system, most of them have proposed methods for system vulnerability analysis using Monte Carlo simulation (MCS). Ref. [22] used the “DC” load flow approximation and linear programming technique to simulate cascading failures and calculate reliability and vulnerability indices. Ref. [23] considers the transient impact on cascading outage. However, most of the previous researches use non-sequential MCS to analyze the system. This is appropriate only when component failures and repairs are independent. It has two limitations: 1) the elements of the system should be independent and 2) it could not give the distribution of the system life time. Since our task is to derive the probability distribution of blackouts, sequential MCS is selected.

Mathematically, the blackout of a power system is a function $T(t;x,y)$ of deterministic vector and random vector. Here x denotes the deterministic vector; and y denotes random vectors. We assume the distribution of Y is known, i.e. $Y \sim f(y;a)$.

Where a is the parameter vector of the distribution. For power system, the analytical method to solve this function is too complex and MCS seems the prefer method to solve the problem. Previous non-sequential MCS could only give the estimation of mean value of random variable $T(t;x,y)$ under the assumption that the elements of random vector are unrelated. For sequential MCS, first we want to deduce the distribution of $T \sim g(t;x,b)$. Secondly, we want to deduce parameter b or part of elements in vector b from a . This will help us to understand the mechanism of blackout and the sensitivity analysis of parameters.

Since the computation of sequential MCS is time consuming, we run the sequential MCS on a parallel computer network to improve the computational efficiency.

This dissertation starts from the two factors involved in blackouts: deterministic and probabilistic factors, from which the mechanism of blackouts is proposed. The mechanism avoids the modeling of the system configuration and the load, and a statistical law is derived for blackouts from the mechanism for power system blackouts. Theoretical proofs of the derivation are provided. Numerical tests show that the proposed statistical law is valid for power system blackouts. Potential applications of this proposed law of blackouts are also suggested in this dissertation.

1.3 Contributions

The contributions of this dissertation to the power system engineering are listed as follows:

1) We investigate the general features of power system blackouts from the study of its mechanism through the employment of statistical and probability theory. The statistical distribution of blackouts is first proposed based on the mechanism model. From the analysis of mechanism of blackout, we classify the blackout into different levels. We statistically analyze the probabilities of cascading failures that can lead to blackouts and proved that each level satisfies Gamma distribution. Then we can deduce that the power system life satisfies mixture of Gamma distribution.

2) How to estimate these parameters of the distribution is also provided in the dissertation. We indicate that the shape parameter γ equals to the order of the level and scale parameter β is only related to the distribution of each component in power system. We find the physical properties of power system (e.g. load, topology, etc) will not affect the distribution of each level. These factors only affect the probabilities of p_k . The conclusion could be used to greatly reduce the simulation samples in order to estimate the parameter with desired accuracy.

3) The theoretical proofs have been provided to justify the validity of the proposed distribution which is shown to be independent of the definition of blackouts and the modeling of power systems. A detailed power system model is built to verify the validity of the proposed distribution.

4) A new simulation program package has been developed to evaluate complex radial distribution systems. In our simulation, load could change with different time and it could also be voltage dependent. Effects of automated switches to distribution system are also studied. The package is very flexible and almost all elements in distribution

systems could be included. Reliability indices on each load have been computed to obtain an overall reliability assessment of the system, and the sensitivity of the reliability indices to the location of automatic switches is also studied.

5) The main disadvantage of the sequential Monte Carlo simulation method is that it is time consuming. The Monte Carlo simulation needs to generate events for thousands of periods to obtain results with an acceptable accuracy. In order to perform Monte Carlo simulation on large system, distributed computation is applied in our program by dividing the large project into smaller chunks and submitting them to a computer cluster consisting of many computers. The Matlab Distributed Computing Toolbox (MDCT) and the Matlab Distributed Computing Engine (MDCE) enable us to coordinate and execute independent Matlab operations simultaneously on a cluster of computers, speeding up execution of large Matlab jobs.

1.4 Synopses of Chapters

The material in this dissertation is organized as follows:

Chapter 1 introduces the general background of the power system blackout, illustrates the motivation and objective of this dissertation, and lists the contribution of this research work.

Chapter 2 discusses the mechanism of blackouts or cascading failures. The statistical law of blackouts and its associated proofs are presented. A discussion is also provided in this chapter for a deeper understanding of the proposed statistical law.

Chapter 3 describes two parts of Monte Carlo simulation: normal modeling and reliability modeling, corresponding to the deterministic and probabilistic factors

respectively. The normal modeling models power systems such that analysis like power flow analysis, short current analysis, transient stability analysis and automatic generator control (AGC) could be appropriately performed. The reliability modeling models power systems such that the statistical characteristics like the failures of transmission lines, generators, protective relays, etc. could be precisely simulated.

Chapter 4 analyzes the simulation results of IEEE 24-bus system and IEEE 118-bus system. Through tracing the cascading process of blackout, we not only get the parameters of system blackout distribution, but also prove the validity of the statistical law deduced in chapter 2.

Chapter 5 presents a computationally efficient Monte Carlo simulation for distribution system reliability assessment. Analysis of the effect of each component's failure on the SAIFI and SAIDI of distribution system and the relation function for each component are provided. The feature of the Monte Carlo simulation used in this work is presented. A simulation program package is developed and described. The results of a practical distribution system are compared using both the historical record and Monte Carlo simulation techniques. The sensitivity analysis of a practical distribution system is presented.

Chapter 6 briefly introduce distributed computation using Matlab Distributed Computing Toolbox (MDCT) and the Matlab Distributed Computing Engine (MDCE)

Chapter 7 states the summary and conclusion of this dissertation and discusses the opportunity for further research.

CHAPTER 2

PROBABILITY DISTRIBUTION OF POWER SYSTEM BLACKOUTS

2.1 Background

The origin of blackout is usually a line tripping caused by overload, sag, animal, or tree falling down. Theoretically, power systems are robust for N-1 contingencies. However, due to hidden failure and human error, one component breakdown may cause a series of components getting out of service. The rapid spread of the cascading failure may finally make the power grid collapse. Even with the use of new technology developed in power engineering, in communication systems, and in computer engineering, it is recognized that these catastrophic events cannot be completely prevented. However, it would be possible to reduce their frequency, severity, and impact on society [15]. The analyses of cascading failures of complex networks have attracted a great deal of attention in recent years [26-28]. Because of the numerous factors involved in operating a complex system, a thorough understanding of the mechanism of a blackout is still unclear. Researchers have attempted to unveil the mystery of blackouts. Blackouts are very complex, and at the current stage of research, efforts are still needed for a thorough physical interpretation of power system blackouts.

In one of the studies, Dr. Ian Dobson of the University of Wisconsin at Madison and his colleagues inaugurated a remarkable quantitative study on blackouts [29]. By

statistically analyzing electric power transmission system blackout of North American for the last 15 years, they concluded that the dynamics of blackouts have some features of self-organized criticality (SOC) systems. SOC systems are characterized by both spectrums of spatial and temporal scales of the disruptions that exist in remarkably similar forms in a wide variety of physical systems [30]. Thus, if a power system has only a spectrum of temporal scales of the disruptions that behave like a SOC system, the power system is not necessarily a SOC system. Furthermore, because the historical data of the 15-year time series of the North American power system do not reflect the same system due to the building of new components (for example, new power plants or transmission lines), the claim that power systems are SOC systems needs further justifications [31].

Because load is one of the most important variables in power systems, which also has a cogent relationship with cascading failure, the load variation is especially studied in the aspect of affecting the dynamics of the power grid [26,27,29]. It is possible that blackouts may follow a certain law when system load is considered as the variable. However, it is also observed that the same amount of load with different patterns may reveal different information regarding blackouts for a system. From the physical system perspective, both load and system configuration have to be taken into consideration when studying the blackouts.

Because of the physical operation constraints and reliability characteristics of components, both deterministic and probabilistic factors are involved in the cascade of

failures. However current research is mainly focused on the deterministic factors of the networks.

This chapter starts from the two factors involved in blackouts: deterministic and probabilistic factors, from which the mechanism of blackouts is proposed. The mechanism avoids the modeling of the system configuration and the load, and a statistical law is derived for blackouts from the mechanism for power system blackouts. Theoretical proofs of the derivation are provided. Numerical tests will show that the proposed statistical law is valid for power system blackouts [32].

2.2 Review of Happened Blackouts

In recent years, many blackouts have occurred in power systems throughout the world [33]. This section provides brief review on some of the major historical blackout incidents in the power systems:

Around 1:31PM on Aug. 14, 2003, a 650MW power plant in Ohio shut down. Half an hour later, 1200MW capacity transmission lines tripped almost at the same time because high temperature caused these lines to sag and touch trees. It has triggered a series of cascading events that eventually led to the worst blackout in the US history.

In March 1999, a zone 3 relay tripped a 440kV line near Sao Paulo, Brazil, resulting in cascading outages of several plants and high voltage AC and DC lines finally leading to a total blackout affecting 75 million people.

In June 1998, a severe lightning storm in Minnesota initiated a series of events, causing a system disturbance that affected the entire Mid-Continent Area Power Pool

Region and the northwestern Ontario Hydro system of Northeast Power Coordinating Council.

In 1997, an ice storm in Quebec, Canada downed transmission lines and blacked out much of New England, USA.

In August 1996, all major transmission lines between Oregon and California were dropped because of line sag and hidden failures, which affected 10 western states.

In July, a falling tree branch in Idaho led to a cascading failure of several power plants and transmission lines blacking out 18 western states in the US.

It is clear that transmission lines form a major link in the cascading failure phenomenon. Although line failure may be caused by overloading, faulty protection setting, overgrown vegetation, or any other unpredictable system or weather conditions, a line failure is often associated with growing system oscillations, voltage or transient instability [33].

By reviewing the history of blackouts, the causes of a blackout can be divided into two types: the primary causes and causes of cascading failures. The primary causes of blackouts related to probabilistic failures: power plant fails, transmission lines fail, relay trips transmission line, an ice storm, etc. However, the causes of cascading failures resulting in large scale blackouts can be further divided into two groups: probabilistic and deterministic. Deterministic causes are defined to be the violations of the physical operating constraints. Table 2.1 summarizes the causes of blackouts.

Table 2.1 Causes of Blackouts

| | Primary Causes | Causes of Cascading | |
|------------------|--|---|---|
| | | Deterministic Factors | Probabilistic Factors |
| Blackouts | 1. Primary protective relay failure 2. Line fault 3. High winds causing line failure 4. Line sagged into trees 5. Hidden failure 6. Lightning 7. Phase-to-ground fault 8. Tower causing multiple lines out 9. A sequence of line trappings 10. Etc. | 1. Under-frequency 2. Overload 3. Over-current 4. Low voltage 5. Etc. | 1. Failure of the tap-changing mechanism 2. Additional lightning 3. Failure of Communication channel 4. Failure of Backup device 5. Operators' unawareness of failures 6. Failure of EMS system 7. Etc. |

A well-designed power system is resilient enough that can easily recover from a single element outage or malfunctioning. Thus no single failures should cause blackouts. Almost all blackouts are triggered by random events ranging from multiple equipment failures and bad weather to vandalism. The blackouts then typically become widespread through a series of cascading events.

2.3 Mechanism of Cascading Failures or Blackouts

From previous review of blackouts, we know that the factors of cascading can be divided into two types: deterministic factors and probabilistic factors.

2.3.1 Deterministic Factors

These factors include all causes that are generated from operation constraints or limits which are determined by physical conditions of power systems. For example, if a line outage causes the overload of neighboring lines, those overloaded lines will trip

because of the settings of their protective relays. Deterministic factors have nothing to do with the probabilistic factors, and they are basically decided by the system configuration, load pattern, capacities of devices, operation limits of devices, etc. But these factors will affect the probabilistic factors. For example, the same system with same possible of line outage, heavy load system will be more vulnerable than the light load system.

2.3.2 Probabilistic Factors

Unlike the deterministic factors, probabilistic factors are solely decided by the reliability characteristics of devices. For example, when a line will fail can not be predicted. It is a random event. But through prior experience, we know that statistically it satisfy a certain distribution, e.g. exponential distribution or gamma distribution; Another example is if a line is out, failure of protective relays in one of its neighboring lines may cause that line out. Whether this will happen is not deterministic either. It is also a random event. All these probabilistic factors and deterministic factors may cause blackouts.

For a given power system, since it is also a random event, it is difficult to predict when a blackout will happen. However, it should be able to fit into a certain distribution that is derived from the deterministic factors and the statistical parameters of probabilistic factors.

Figure 2.1 provides graphical demonstration regarding the process of cascading failures.

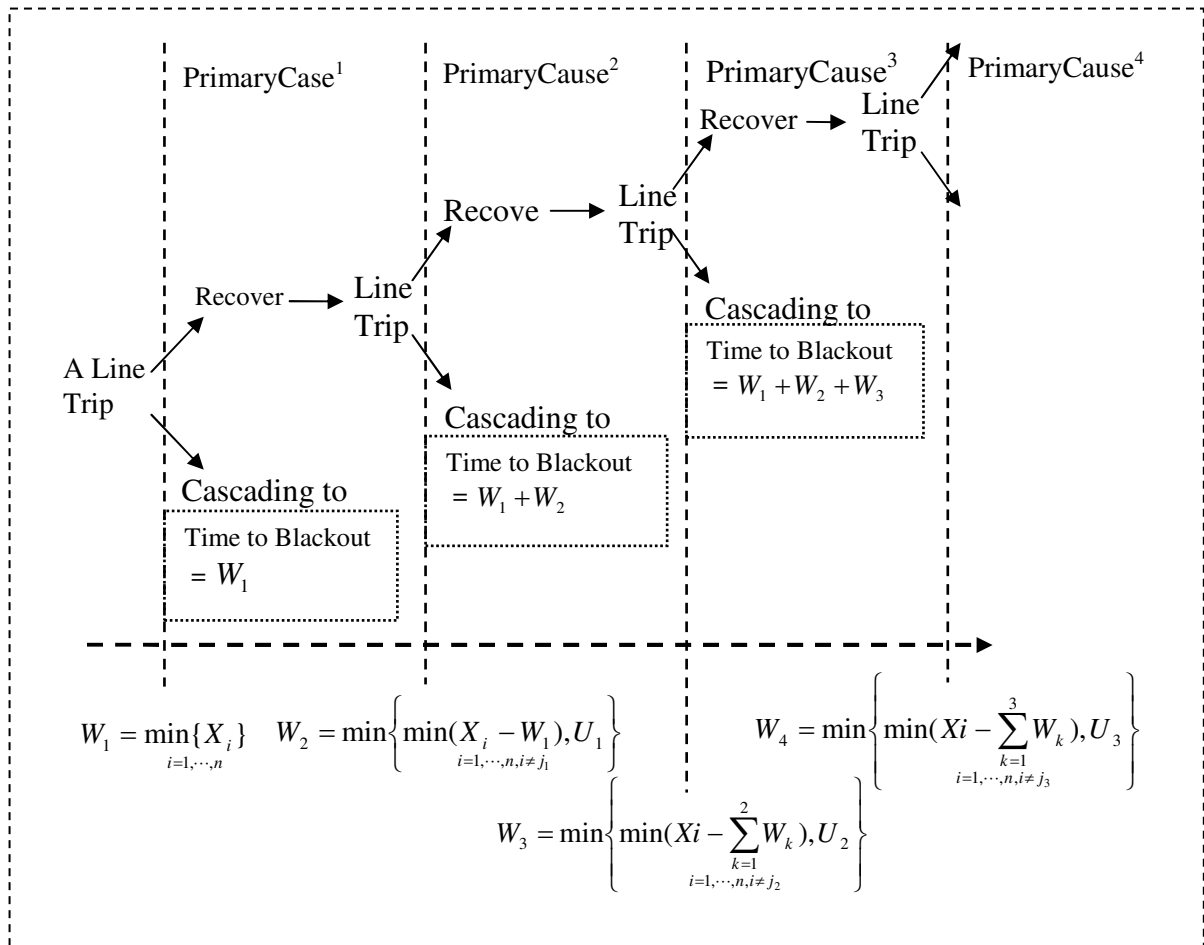

Figure 2.1 Mechanism of Cascading Failures or Blackouts

One can see that when a line is out due to the operation of protective relays, there are two possibilities: a cascading failure leading to a blackout; or the system recovers. For the case of a cascading failure leading to a blackout, the conditions of cascading include deterministic and/or probabilistic factors; for the case of the system recovery, the number of line outage might be one or more. After the system's recovery, the system is waiting for another incident; we call the next event as PrimaryCause2. If the system recovers again, then it will wait for PrimaryCause3. This process will continue until a blackout happens.

Blackouts are not clearly defined in the literature so far. Before we study the blackouts, first of all, we have to clarify their definitions [31].

Generally, “blackouts” means the loss of loads in a large area with a considerable duration. The difference between the definitions of blackouts and cascading failures is as follows:

- Blackouts are caused by cascading failures;
- Cascading failures do not necessarily cause blackouts.

It highly depends on the scale of the loss of loads by cascading failures, or the definition of blackouts. If the scale is large enough, then cascading failures cause blackouts; otherwise, cascading failures do not cause blackouts.

However, it is worth noting that the form of the proposed statistical distribution of blackouts in this paper is valid for any definition of blackouts which only affect the parameters in the proposed distribution.

2.4 Statistical Distribution of Blackouts

2.4.1 Preliminary Theory

Based on previous discussion, we can begin to statistically analyze the probabilities of cascading failures that can lead to blackouts. Suppose a system has n components C_1, \dots, C_n . Let X_i be life span of the component C_i with the distribution function F_i ; namely $P(X_i \leq x) = F_i(x)$, $x \geq 0$. Let $f_i = F_i'$ the density function of X_i . Suppose $X_i \sim \exp(\lambda_i)$, $1 \leq i \leq n$, be independent. Now let $W_1 = \min(X_1, \dots, X_n)$ and consider $X_1 - W_1, X_2 - W_1, \dots, X_n - W_1$. Then replace the smallest (which is zero) by an independent exponential distribution, which forms a new set of random numbers.

Similarly, let $W_2 = \min\left\{\min_{i=1, \dots, n, i \neq j_1}(X_i - W_1), U_1\right\}$ and consider $X_1 - W_1 - W_2, X_2 - W_1 - W_2, \dots, X_n - W_1 - W_2$. Replace the smallest by an independent exponential distribution, which forms a new set of random numbers.

Continue this process and we can reach the m -th step: let $W_m = \min\left\{\min_{i=1, \dots, n, i \neq j_2}(X_i - \sum_{k=1}^{m-1} W_k), U_{m-1}\right\}$ and consider $X_1 - \sum_{i=1}^{m-1} W_i, X_2 - \sum_{i=1}^{m-1} W_i, \dots, X_n - \sum_{i=1}^{m-1} W_i$.

Fig. 2.1 also gives the time at every PrimaryCause. The down time of PrimaryCause¹ is given by $W_1 = \min\{X_i, i=1, \dots, n\}$ which is the down time of the first faulted line or device. If more than one line or device is out, X_1 is still the down time of the first line, while the time of relays trip causing other lines out is small enough to be ignored. Furthermore, the up time of all the down devices is contained in X_2 , therefore, the time between PrimaryCause¹ and PrimaryCause² is X_1 , and the time between PrimaryCause² and PrimaryCause³ is X_2 , etc. The following proposition is obviously obtained from Fig.2.1.

Proposition 1. Based on Fig. 2.1, if a blackout occurs after k -th PrimaryCause, then the time to blackout is the sum of all the time used by k PrimaryCauses, $T_k = \sum_{i=1}^k W_i$.

The following Theorem shows that W_1 follows the exponential distribution.

Theorem 1. Assume that the limit

$$\lim_{m \rightarrow \infty} \frac{1}{m} \sum_{i=1}^m f_i(0) = \lambda \text{ exists.}$$

Then $W_1 = \min\{X_i, i = 1, \dots, n\}$ is asymptotically distributed as the exponential distribution with parameter $\sum_{i=1}^n \lambda_i$.

Proof:

Since X_1, \dots, X_n are independent, for $t \geq 0$, we have

$$P(T \geq t) = \prod_{i=1}^n P(X_i \geq t) = \prod_{i=1}^n [1 - F_i(t)]$$

Therefore, for small t ,

since $F_i(0)=0$, $\log(1 - \delta) = -\delta + O(\delta^2)$ and $F_i(t) - F_i(0) \approx t f_i(0)$,

$$\begin{aligned} \log P(T \geq t) &= \sum_{i=1}^n \log[1 - F_i(t)] \\ &= \sum_{i=1}^n [F_i(t) + O(F_i^2(t))] \\ &= \sum_{i=1}^n [f_i(0)t + O(t^2)] \rightarrow \lambda t \end{aligned}$$

In the special case where X_i is exponential distribution, then W_1 is also an exponential distribution. ■

Obviously, $W_1 \sim \exp(\lambda)$, where $\lambda = \sum_{i=1}^n \lambda_i$. Now consider the sequence $X_1 - W_1, X_2 - W_1, \dots, X_n - W_1$, and the smallest $X_T - W_1$ (which is zero since $X_T = W_1 = \min(X_1, \dots, X_n)$) is replaced by an independent exponential random variable U with parameter λ_T . Then we will show that sequence $(X_1 - W_1, X_2 - W_1, \dots, X_{T-1} - W_1, U, X_{T+1} - W_1, \dots, X_n - W_1)$ has the same distribution as the original sequence (X_1, X_2, \dots, X_n) .

Theorem 2. We have the distributional equality

$$(X_1 - W_1, X_2 - W_1, \dots, X_{T-1} - W_1, U, X_{T+1} - W_1, \dots, X_n - W_1) =_D (X_1, \dots, X_n)$$

Proof:

Let $x_1, \dots, x_n > 0$ and

$$A = \{X_1 - W_1 \geq x_1, \dots, X_{T-1} - W_1 \geq x_{T-1}, U \geq x_T, \\ X_{T+1} - W_1 \geq x_{T+1}, \dots, X_n - W_1 \geq x_n\}.$$

Then $\mathbf{P}(A) = \sum_{t=1}^n \mathbf{P}(A, T=t)$. Let $1 \leq t \leq n$. Since $\{T=t\}$ implies that X_t is the

smallest and hence $X_t = W_1$,

$$\begin{aligned} \mathbf{P}(A, T=t) &= \mathbf{P}(X_1 - X_t \geq x_1, \dots, X_{t-1} - X_t \geq x_{t-1}, \\ &\quad U \geq x_t, X_{t+1} - X_t \geq x_{t+1}, \dots, X_n - X_t \geq x_n) \\ &= e^{-\lambda_t x_t} P(X_1 - X_t \geq x_1, \dots, X_{t-1} - X_t \geq x_{t-1}, \\ &\quad X_{t+1} - X_t \geq x_{t+1}, \dots, X_n - X_t \geq x_n) \\ &= e^{-\lambda_t x_t} \int_0^\infty e^{-\sum_{j=1}^n \lambda_j (z+x_j) + \lambda_t (z+x_t)} dz \\ &= \int_0^\infty e^{-\sum_{j=1}^n \lambda_j (z+x_j) + \lambda_t z} dz \end{aligned}$$

So the conditional probability is

$$\begin{aligned} \mathbf{P}(A | T=t) &= \frac{\mathbf{P}(A, T=t)}{\mathbf{P}(T=t)} \\ &= \frac{\int_0^\infty e^{-\sum_{j=1}^n \lambda_j (z+x_j) + \lambda_t z} dz}{\int_0^\infty e^{-\sum_{j=1}^n \lambda_j z + \lambda_t z} dz} \\ &= e^{-\sum_{j=1}^n \lambda_j x_j} \end{aligned}$$

Therefore, $\mathbf{P}(A) = e^{-\sum_{j=1}^n \lambda_j x_j}$ and the Theorem is proven. ■

From Theorem 1 and 2, we have the following lemma.

Lemma 1. Let $X_i \sim \exp(\lambda_i)$, $1 \leq i \leq n$, be independent. Now let $W_1 = \min(X_1, \dots, X_n)$ and $W_m = \min(X_1 - \sum_{i=1}^{m-1} W_i, \dots, X_n - \sum_{i=1}^{m-1} W_i)$, $m = 1, \dots$. Theorem 1 and 2 imply that W_m are all exponential distribution with the same parameter $\lambda = \sum_{i=1}^n \lambda_i$.

Theorem 1 shows that W_1 follows exponential distribution;

Theorem 2 implies that W_2 has the same distribution as W_1 because the two sequences where W_1 and W_2 are obtained have the distributional equality. Applying the same logic reasoning, we then know that Lemma 1 is true.

2.4.2 Distribution of PrimaryCause

2.4.2.1 Distribution of PrimaryCause¹

In Fig. 2.1, when a line is tripped due to a fault, if there is no overload on other lines and no hidden failures on the protective relays, this line will be waiting for repair. If there is a hidden failure on a protective relay (normally its neighboring relay), the corresponding line will be tripped due to the mis-operation of the relay. Now suppose that a system has m transmission lines R_1, \dots, R_m . Let Y_i be the life span of the protective relay R_i , which has the distribution function F_i ; namely, $P(Y_i \leq y) = F_i(y)$, $y \geq 0$. Let $f_i = F_i'$ be the probability density function of Y_i . Suppose $Y_i \sim \exp(\xi_i)$, $1 \leq i \leq m$, are independent.

When a line is tripped due to a fault, whether another line is tripped in succession because of a hidden failure is decided by which one of its neighboring relays is already at the state of failure. So, the probability of another line that is tripped due to

hidden failure is the condition probability $P(X_i > x_i | X_i > Y_j)$. The following theorem shows that the distribution of the PrimaryCause¹ is a mixture of exponential distribution.

Theorem 3. The distribution of blackouts due to the PrimaryCause¹ is a mixture of exponential distribution.

Proof:

To calculate this probability, we need to calculate the following probabilities.

$$\begin{aligned}
 & P(X_i > Y_j) \\
 &= \iint_{x>y>0} \lambda_i e^{-\lambda_i x} \zeta_j e^{-\zeta_j y} dx dy \\
 &= \frac{\zeta_j}{\lambda_i + \zeta_j}
 \end{aligned}$$

And

$$\begin{aligned}
 & P(X_i > x, X_i > Y_j) \\
 &= \int_{x=x_0}^{\infty} \int_{y=0}^x \lambda_i e^{-\lambda_i x} \zeta_j e^{-\zeta_j y} dx dy \\
 &= e^{-\lambda_i x} - \frac{\lambda_i e^{-(\lambda_i + \zeta_j)x}}{\lambda_i + \zeta_j}
 \end{aligned}$$

So we have

$$\begin{aligned}
 & P(X_i > x | X_i > Y_j) \\
 &= \frac{P(X_i > x, X_i > Y_j)}{P(X_i > Y_j)}
 \end{aligned}$$

$$= \frac{(\lambda_i + \zeta_j)e^{-\lambda_i x} - \lambda_i e^{-(\lambda_i + \zeta_j)x}}{\zeta_j}$$

The probability density function (pdf) is

$$\begin{aligned} & \frac{d}{dx} P(X_i > x, X_i > Y_j) \\ &= \frac{\lambda_i(\lambda_i + \zeta_j)}{\zeta_j} \left[e^{-\lambda_i x} - \lambda_i e^{-(\lambda_i + \zeta_j)x} \right] \end{aligned}$$

■

The distribution in Theorem 3 is a negatively exponential since the coefficient $e^{-(\lambda_i + \zeta_j)x}$ is negative. The latter distribution is different from the one in the literature, which is positive mixed.

In order to derive the blackout distribution recursively, we use a Gamma distribution to approximate this new distribution. For the distribution with pdf $g(x) = \lambda_i(\lambda_i / \zeta_j + 1)(e^{-\lambda_i x} - \lambda_i e^{-(\lambda_i + \zeta_j)x})$, we start to approximate it with the Gamma distribution of the form $f_{k,\theta}(x) = x^{k-1} e^{-\frac{x}{\theta}} / \Gamma(k)$. We shall apply the method of moments and derive the parameters (k, θ) such that $g(x)$ can be best approximated by $f_{k,\theta}(x)$.

Because

$$\int_0^{\infty} x g(x) dx = \frac{1}{\lambda_i} + \frac{1}{\lambda_i + \zeta_j}$$

And

$$\int_0^{\infty} x^2 g(x) dx = \frac{6\lambda_i^2 + 6\lambda_i\zeta_j + 2\zeta_j^2}{\lambda_i^2(\lambda_i + \zeta_j)^2}$$

Furthermore, observe that

$$\int_0^{\infty} x f_{k,\theta}(x) dx = k\theta$$

And

$$\int_0^{\infty} x^2 f_{k,\theta}(x) dx = k\theta^2 + k^2\theta^2$$

Comparing the above equations, the parameters (k, θ) are solved:

$$\begin{cases} \theta = \frac{2\lambda_i^2 + 2\lambda_i\zeta_j + \zeta_j^2}{\lambda_i(\lambda_i + \zeta_j)(2\lambda_i + \zeta_j)} \\ k = \frac{4\lambda_i^2 + 4\lambda_i\zeta_j + \zeta_j^2}{2\lambda_i^2 + 2\lambda_i\zeta_j + \zeta_j^2} \end{cases}$$

Remarks:

1. It should be noted that normally $1 < k < 2$. However, if $\lambda_i \gg \zeta_j$ (which means that the transmission lines are much more prone to fault than the relays), then $k \approx 2$.
2. According to Theorem1, if we do not consider the hidden failures, blackouts due to the PrimaryCause¹ follow an exponential distribution instead of a Gamma distribution. Because power systems can tolerate N-1 contingencies under regular load patterns, a cascading failure occurs only when hidden failures exist. That is the reason why the distribution of the PrimaryCause¹ becomes a Gamma distribution.

2.4.2.2 Distribution of PrimaryCause² and Higher Causes

If the tripped transmission line is recovered because of non-cascading failures, then the recovered power system will be waiting for the next trip of a line. Now we

need to derive the probability that tripped transmission lines do not cause further lines out.

Theorem 4. The PrimaryCause¹ defined in Fig. 2.1, which does not cause any blackouts, follows an exponential distribution.

Proof:

For $X_i \sim \exp(\lambda_i), 1 \leq i \leq n$, and $Y_i \sim \exp(\zeta_i), 1 \leq i \leq m$, we have the following theorem.

$$\begin{aligned}
 & P(X_i > x_0, X_i < Y_j) \\
 &= \int_{x=x_0}^{\infty} \int_{x < y} \lambda_i e^{-\lambda_i x} \zeta_j e^{-\zeta_j y} dx dy \\
 &= \int_{x=x_0}^{\infty} \lambda_i e^{-\lambda_i x} e^{-\zeta_j x} dx \\
 &= \frac{\lambda_i}{\lambda_i + \zeta_j} e^{-(\lambda_i + \zeta_j)x_0}
 \end{aligned}$$

Let $x_0=0$ in the above expression, we know that $P(X_i < Y_j) = \frac{\lambda_i}{\lambda_i + \zeta_j}$. So we have:

$$\begin{aligned}
 & P(X_i > x | X_i < Y_j) \\
 &= \frac{P(X_i > x, X_i < Y_j)}{P(X_i < Y_j)} \\
 &= e^{-(\lambda_i + \zeta_j)x}
 \end{aligned}$$

which finishes the proof. ■

Now, we show how the distribution of the PrimaryCause² defined in Fig. 2.1 can be approximated by Gamma distributions.

Let $X_i \sim \exp(\lambda_i), 1 \leq i \leq n$; $Z_l \sim \exp(\xi_l = \lambda_i + \zeta_j)$,

where $Z_l = X - W, 1 \leq i \leq n$; $Y_i \sim \exp(\zeta_i), 1 \leq i \leq m$. We want to approximate the conditional distribution $[X_i + Z_l | X_i + Z_l > Y_j]$ by a Gamma distribution.

Let $S = X_i + Z_l$; S then has a pdf as follows

$$\begin{aligned} f_S(s) &= \int_0^s \lambda_i e^{-\lambda_i t} \xi_l e^{-\xi_l (s-t)} dt \\ &= \lambda_i \xi_l e^{-\xi_l s} \int_0^s e^{-(\lambda_i - \xi_l)t} dt \\ &= \frac{\lambda_i \xi_l}{\xi_l - \lambda_i} (e^{-\lambda_i s} - e^{-\xi_l s}) \end{aligned}$$

Let us define $f_{Y_j}(y_j) = \zeta_j e^{-\zeta_j y}$ as the density of Y_i . Then,

$$F_{Y_j}(y_j) = 1 - e^{-\zeta_j y}$$

$$A := P(S > Y_j) = E\{F_{Y_j}(S)\} = \int_0^{\infty} f_S(s) F_{Y_j}(s) ds \quad (*)$$

and

$$\begin{aligned} &P(S > a, S > Y_j) \\ &= \int_a^{\infty} \int_0^s f_S(s) F_{Y_j}(y_j) dy_j ds \\ &= \int_a^{\infty} f_S(s) F_{Y_j}(s) ds \end{aligned}$$

Hence, the conditional density is

$$\begin{aligned} & \frac{d}{da} P(S = X_i + Z_l \leq a \mid S_i > Y_j) \\ &= \frac{f_S(a)F_{Y_j}(a)}{\int_a^\infty f_S(s)F_{Y_j}(s)ds} \end{aligned}$$

Recalling Eq. (*), we have

$$\begin{aligned} A &= \int_0^\infty (1 - e^{-\zeta_j s}) \frac{\lambda_i \xi_l}{\xi_l - \lambda_i} (e^{-\lambda_i s} - e^{-\xi_l s}) ds \\ &= \frac{\lambda_i \xi_l}{\xi_l - \lambda_i} \left(\frac{1}{\lambda_i} - \frac{1}{\xi_l} - \frac{1}{\zeta_j + \lambda_i} + \frac{1}{\zeta_j + \xi_l} \right) \\ &= 1 - \frac{\lambda_i \xi_l}{\xi_l - \lambda_i} \frac{\xi_l - \lambda_i}{(\zeta_j + \lambda_i)(\zeta_j + \xi_l)} \\ &= 1 - \frac{\lambda_i \xi_l}{(\zeta_j + \lambda_i)(\zeta_j + \xi_l)} \end{aligned}$$

Next, we will compute the first and second moments of the distribution in

Eq.(*). To this end, let

$$\begin{aligned} M_1 &= \frac{1}{A} \int_0^\infty a f_S(a) F_{Y_j}(a) da \\ &= \frac{1}{A} \int_0^\infty a (1 - e^{-\zeta_j a}) \frac{\lambda_i \xi_l}{\xi_l - \lambda_i} (e^{-\lambda_i a} - e^{-\xi_l a}) da \\ &= \frac{1}{A} \frac{\lambda_i \xi_l}{\xi_l - \lambda_i} \left(\frac{1}{\lambda_i^2} - \frac{1}{\xi_l^2} - \frac{1}{(\zeta_j + \lambda_i)^2} + \frac{1}{(\zeta_j + \xi_l)^2} \right) \end{aligned}$$

The second moment is

$$\begin{aligned}
M_2 &= \frac{1}{A} \int_0^{\infty} a^2 f_w(a) F_{Y_j}(a) da \\
&= \frac{1}{A} \int_0^{\infty} a^2 (1 - e^{-\zeta_j a}) \frac{\lambda_i \xi_l}{\xi_l - \lambda_i} (e^{-\lambda_i a} - e^{-\xi_l a}) da \\
&= \frac{2}{A} \frac{\lambda_i \xi_l}{\xi_l - \lambda_i} \left(\frac{1}{\lambda_i^3} - \frac{1}{\xi_l^3} - \frac{1}{(\zeta_j + \lambda_i)^3} + \frac{1}{(\zeta_j + \xi_l)^3} \right)
\end{aligned}$$

With M_1 and M_2 computed, we can approximate the distribution of the PrimaryCause² by Gamma distribution, where pdf is $f_{k,\theta}(x) = x^{k-1} e^{-\frac{x}{\theta}} \theta^{-k} / \Gamma(k)$.

If we let $M_1 = k\theta$ and $M_2 = (k^2 + k)\theta^2$, we obtain

$$\begin{cases} \theta = \frac{M_2}{M_1} - M_1 \\ k = \frac{M_1^2}{M_2 - M_1^2} \end{cases}$$

The density function of PrimaryCause beyond PrimaryCause² defined in Fig. 2.1 can be approximated by a Gamma distribution in a similar way.

If $X_m \sim \Gamma(k_m, \theta_m), 1 \leq m \leq I$, the density function of $Q = X_1 + X_2 + \dots + X_I$ can be derived as follows:

Let

$$M_1 = k_1 \theta_1 + k_2 \theta_2 + \dots + k_I \theta_I$$

and

$$M_2 = (k_1^2 + k_1) \theta_1^2 + (k_2^2 + k_2) \theta_2^2 + \dots + (k_I^2 + k_I) \theta_I^2$$

Then we have

$$Q \sim \Gamma(k, \theta),$$

where

$$\begin{cases} \theta = \frac{M_2}{M_1} - M_1 \\ k = \frac{M_1^2}{M_2 - M_1^2} \end{cases}$$

2.4.3 Distribution of Blackouts

According to Proposition 1, the time of blackouts is a sum of X_i which follows the exponential distribution. Therefore, it is obvious that the overall distribution of blackouts should be the mixture of Gamma distributions.

The classical Gamma distribution with shape parameter γ and scale parameter β has the density function

$$f_{\gamma,\beta}(x) = \frac{x^{\gamma-1} \exp(-x/\beta)}{\beta \Gamma(\gamma)}, \quad x \geq 0. \quad (2.1)$$

To be more specific, let X_k be a Gamma random variable with shape parameter k and scale parameter β (because of Lemma 1); let X be the life of the system which takes the value X_k with probabilities p_k , $1 \leq k \leq K_0$, where K_0 is the maximal times of PrimaryCauses. The mixture probabilities p_k satisfies $\sum_{k=1}^{K_0} p_k = 1$. Then the distribution function of X is given by

$$P(X \leq x) = \sum_{k=1}^{K_0} p_k P(X_k \leq x) \quad (2.2)$$

and its probability density function is

$$f(x) = \sum_{k=1}^{K_0} p_k f_{k,\beta}(x), \quad x \geq 0. \quad (2.3)$$

Based on this formula, we can get the mean [34]

$$E(X) = \sum_{k=1}^{K_0} k\beta p_k \quad (2.4)$$

And the second moment

$$E(X^2) = \sum_{k=1}^{K_0} p_k (k^2\beta^2 + k\beta^2). \quad (2.5)$$

In practice, the mixture probabilities p_k and the scale parameter β can be estimated from the data. Based on which we can obtain the hazard function $f(x)/P(X > x)$, so that the time of blackout can be predicted with certain pre-assigned confidence levels.

It has to be noted that the form of the above proposed distribution function and density function do not depend on the definition of blackouts. The definition of blackouts only affects the value of the mixture probabilities p_k . The way to calculate the mixture probabilities p_k is given in [12].

2.4.4 Discussion of the Proposed Distribution of Blackouts

We have proposed the distribution of blackouts in previous sections. In this section, we will discuss the conditions where the proposed distribution is valid.

The proposed distribution is based on the mechanism given in Figure 2.1. Figure 2.1 contains the following assumptions:

1) Assumption:

The repair time of faulted lines is small compared with power system life time so that it can be ignored. The operation experience shows that the above assumption is

reasonable. But we include the possibility of the occurrence of another component fault during the process of return after each PrimaryCause.

2) Conditions of Validity

The conditions of validity of the proposed distribution are given as follows:

- The validity of Fig. 2.1 is independent of the components including transmission lines. The proposed distribution is held when all components likely to be fault are considered.

- The proposed distribution is also true when all reasons of faults are considered once all the reasons are modeled by exponential distributions.

- From the Theorem 1, we know the condition of each component should satisfy exponential distribution is not necessary. We can relax this condition to any non-negative distribution if only their probability density function exit at $t = 0$;

- The proposed distribution is true for different criterions or definition of blackouts. That means different criterions of blackouts can only affect the parameters in the proposed distribution other than the form of the proposed distribution.

- The proposed distribution is independent of the load levels. This means that for different load levels blackouts should have the same form of distribution but with different values of parameters.

- The deterministic factors are reflected in the parameters p_k . For different physical operating conditions and constraints, p_k is different.

2.5 Summary

This chapter investigated the general features of power system blackouts from the study of its mechanism through the employment of statistical and probability theory. The mechanism model of blackouts is presented, and the deterministic and probabilistic factors involved in blackouts are introduced. The statistical distribution of blackouts is proposed based on the mechanism model.

From the analysis of mechanism of blackout, we classify the blackout into different levels. We have proved that each level satisfy gamma distribution. The probability density function is:

$$f_{\gamma,\beta}(x) = \frac{x^{\gamma-1} \exp(-x/\beta)}{\beta\Gamma(\gamma)}, \quad x \geq 0. \quad (2.6)$$

Where the shape parameter γ is the order of the level and scale parameter β is only related to the distribution of each component in power system. For example, if n components all satisfy exponential distribution (which is not necessary) with parameter λ_i , then $\beta = \sum_{i=1}^n \lambda_i$.

From above analysis, we find the physical properties of power system (e.g. load, topology, etc) will not affect the distribution of each level. These factors only affect the probabilities of p_k . So the pdf of system blackout is:

$$f(x) = \sum_{k=1}^{\infty} p_k f_{k,\beta}(x), \quad x \geq 0. \quad (2.7)$$

Where p_k is the probability of blackout happened in level k and $\sum_{k=1}^{\infty} p_k = 1$

The theoretical proofs have been provided to justify the validity of the proposed distribution which is shown to be independent of the definition of blackouts and the modeling of power systems. Numerical results will verify the validity of the proposed distribution in chapter 4. Applications of this proposed distribution are needed to be studied to improve the reliability and security of power system expansion and operations.

CHAPTER 3

POWER SYSTEM MODELING IN MONTE CARLO SIMULATION

The modeling of power systems in Monte Carlo simulation includes two parts: power system modeling and reliability modeling, which correspond to the deterministic and probabilistic factors, respectively. Power system modeling simulates power system in such a way that analyses like Power Flow analysis, Short Circuit analysis, Transient Stability analysis and AGC can be appropriately performed. Reliability modeling models power systems in such a way that statistical characteristics like the failures of transmission lines, generators, protective relays, etc., can be precisely simulated. The details of the modeling are provided in the following sections.

3.1 Power System Modeling

Since Power Flow and Short Circuit analyses are commonly used in power systems, they will not be discussed here. Instead, a brief description of Transient Stability analysis and AGC will be discussed.

3.1.1 Time Domain Simulation

Classical research on transient stability of power system relies on the use of reduced network models that represent the system as an n-port. Based on these models, loads have to be considered as constant impedance. It will hide some properties of power system network. In our simulation, we abandon reduced network models and

propose to leave its structure in its original form. Structure-preserving model first was report in 1985[33]. Attached to each bus there is a machine or a load, and the buses are interconnected through transmission lines. Generator dynamics are represented by the classical model and network model are considered. The structure-preserving model allows a more realistic treatment of the loads and it fosters a more nature view of the entire network as the power-preserving interconnection of its components.

A sufficiently accurate model of short term power system behavior is obtained when machines are represented using classical machine model [34]:

$$\begin{aligned}
 \dot{\delta}_i &= \varpi_i & i=2,\dots,m \\
 M_i \dot{\varpi}_i &= T_{mi} + P_{Li} - \sum_{k=1}^n V_i V_k Y_{ik} \cos(\delta_i - \delta_k - \theta_{ik}) & i=2,\dots,m \\
 \sum_{k=1}^n V_i V_k Y_{ik} \cos(\delta_i - \delta_k - \alpha_{ik}) &= P_{Li} & i=m+1,\dots,n \\
 \sum_{k=1}^n V_i V_k Y_{ik} \sin(\delta_i - \delta_k - \alpha_{ik}) &= Q_{Li} & i=m+1,\dots,n
 \end{aligned}
 \tag{3.1}$$

where

δ_i = generator rotor angle

ϖ_i = generator rotor speed

M_i = mechanical starting time

T_{mi} = mechanical torque

The differential algebraic equations (DAEs) (3.1) can be solved by forward Euler method or Trapezoidal method. The forward Euler integration method is generally faster but less accurate than the trapezoidal method. The trapezoidal method is widely used in most power system software packages. It is proved to be very robust and reliable in our simulations.

For a generic time t , assume a time step Δt , the equations (3.1) will become the following problem[35]:

$$\begin{aligned} f(x(t + \Delta t), y(t + \Delta t), f(t)) &= 0 \\ g(x(t + \Delta t), y(t + \Delta t)) &= 0 \end{aligned} \quad (3.2)$$

where f and g represent the differential and algebraic equations and f is a function that depends on the integration method. Equations (3.2) are nonlinear and their solutions are obtained by means of Newton-Raphson technique which in turn consists of computing iteratively the increment Δx and Δy of the state and algebraic variables and updating the actual variables

$$\begin{aligned} \begin{bmatrix} \Delta x^i \\ \Delta y^i \end{bmatrix} &= - \begin{bmatrix} I - 0.5\Delta t F_x^i & -0.5\Delta t F_y^i \\ G_x^i & J_{LFV}^i \end{bmatrix}^{-1} \begin{bmatrix} f^i \\ g^i \end{bmatrix} \\ \begin{bmatrix} x^{i+1} \\ y^{i+1} \end{bmatrix} &= \begin{bmatrix} x^i \\ y^i \end{bmatrix} + \begin{bmatrix} \Delta x^i \\ \Delta y^i \end{bmatrix} \end{aligned} \quad (3.3)$$

where I is the identity matrix of the same dimension of the dynamic order of the system, and the other matrices are the Jacobian matrices of the algebraic differential equations, i.e. $F_x = \nabla_x f$, $F_y = \nabla_y f$, $G_x = \nabla_x g$, $J_{LFV} = \nabla_y g$

$$\text{and } f^i = x^i - x(t) - 0.5\Delta t(f^i + f(t)).$$

When the system changes from one topology to another, the time span of each simulation depends upon the fault-clearing time set by the protection relays. The initial condition of each differential equation is the final state of the previous equation.

After solving the above differential algebra equations, we can get the δ curve for different generators. A simple way to judge whether the system can remain stable is if, in a certain period (for example 10 s), the maximum angle difference does not exceed the maximum security relative to swing angle (default value is 180°).

Generally, “blackout” means the loss of electricity in a large area with a considerable duration. Here, we consider that a blackout occurs when one of the following conditions is satisfied:

- The system loses its transient stability.
- The system frequency deviation is greater than 2 Hz.
- The loss of loads in the system is more than 20% of the total load.

When using the sequential MCS model to simulate system operations, the process will be stopped and the lifetime of the system will be recorded whenever one of the above conditions is encountered. Then we refresh the system data and start the simulation for other sequence of event. This process continues until the mean time of the system life converges.

3.1.2 Automatic Generator Control (AGC)

AGC response is much slower than the governor response [36]. Normally, AGC sends signals out every 4 s in operations. The purpose of AGC is to bring the system frequency back to base frequency (60 Hz) when there is an imbalance between the

generation and the load, while governor attempts to re-balance the generation and load at a certain frequency. The basic idea is to find a way for generation to be re-distributed after load curtailment. Thus, it is not important to know the transient response of the system. Instead, the steady-state target frequency is good enough in AGC simulation.

We set the procedure as follows:

1. Fault period (0 ~ 1 s)

System wide generation; G_0 , load; L_0 .

Use TS analysis to check whether the system is stable after a topology change. If yes, go to step 2; otherwise stop.

2. Governor action period (1 ~ 4 s) :

If there is no load curtailment (ΔP), then no frequency change occurs and no governor action is taken. Otherwise:

a. Calculate the target frequency f .

b. Calculate load changes due to frequency change (ΔL).

c. Calculate generation change due to frequency change (ΔG).

d. Update the load ($L_1 = L_0 - \Delta P + \Delta L$) and the generation ($G_1 = G_0 - \Delta G$) levels.

3. If no additional outage occurs before AGC response (within 4 s), update the load ($L_2 = L_0 - \Delta P$) and generation ($G_2 = G_0 - \Delta P$) excluding ΔL and ΔG . This mimics the AGC response.

4. If there is generation insufficiency due to loss of generators, AGC cannot return the frequency to 60 Hz. The target frequency and corresponding load and generation changes can be obtained in a similar way as in step 2. If the frequency drop exceeds

a certain level, the under-frequency relay (UFR) should operate and shed part of load.

The parameters needed in the simulation include:

D : Damping constant

R : Percent speed regulation or droop

$$\beta : \frac{1}{R} + D.$$

These parameters are known, or we can use some typical values. Because we consider only one area system, with $AGC, ACE = \beta \Delta f = 0$, provided there is no generation insufficiency [37]. Figure 3.1 shows the flowchart for the additional consideration of the governor and AGC .

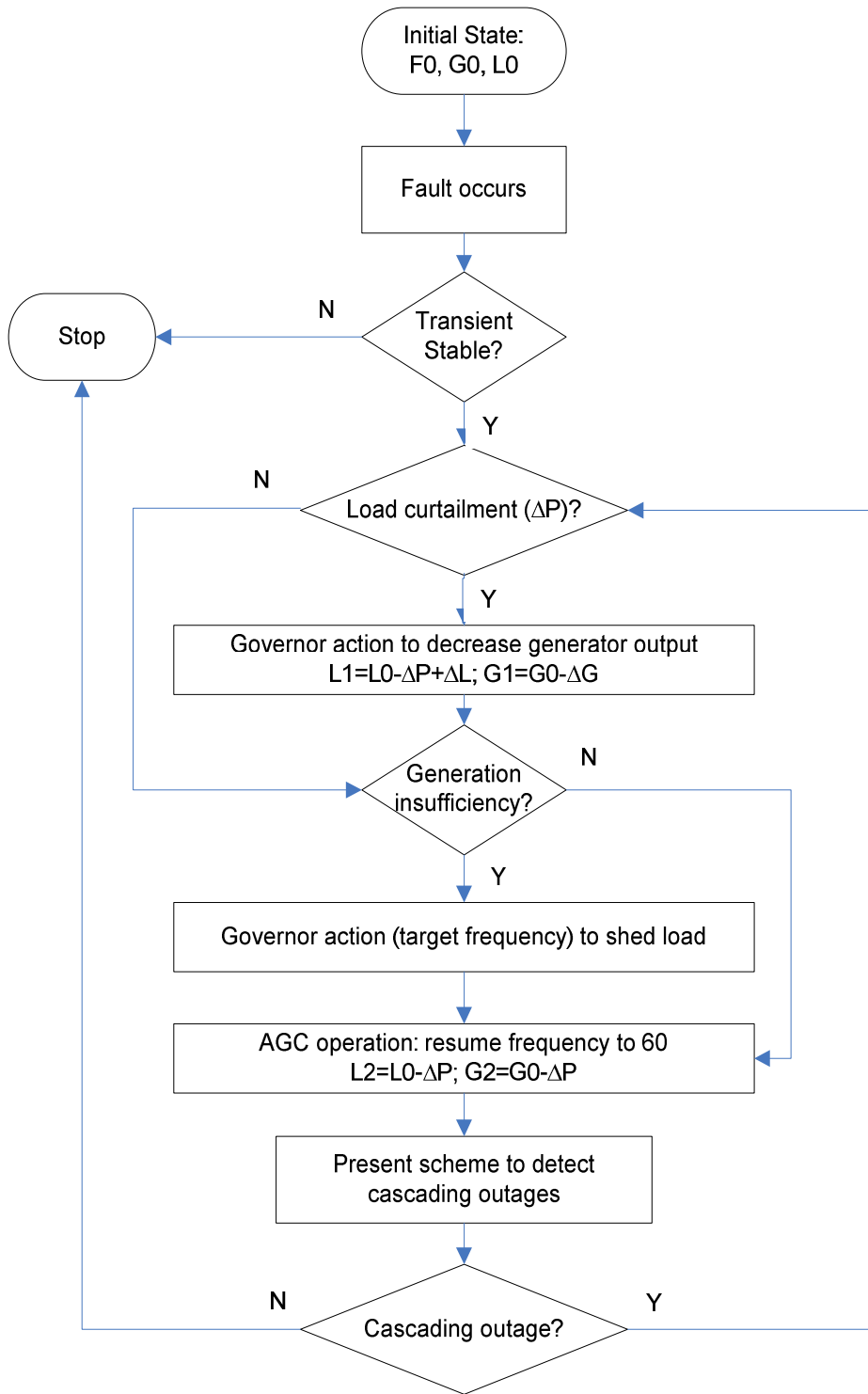

Figure 3.1 Flowchart of governor and AGC procedures

3.1.3 Hidden Failure

Among all the probabilistic factors closely related to blackouts, hidden failure is observed to be the most dominant one [7, 13, 14]. Normally, power systems are designed to be able to withstand an N-1 contingency, which is to say that taking one line out of the system will not cause cascading failure. However, hidden failure of the protective relays can cause additional lines to go out service after an N-1 contingency. Detail hidden failure modeling is provided in the following section.

A hidden failure is a defect from which any of the protection system elements may suffer. Each line has a different load-dependent probability of incorrect trip, which is modeled as an increasing function of the line current seen by the line protective relay. The probability is low when the line flow is below its zone III setting point and it increases linearly to 1 when the line flow is beyond its protection zone I setting point.

In accordance with hidden failure definition, a “failure to operate” will also be considered as a hidden failure. If a relay fails to clear the fault, then all the lines connected to the faulted lines (called exposed lines) will be tripped.

In other words, there are two modes of hidden failure: “refuse to trip” and “unwanted tripping” [19]. “Refuse to trip” means that when a fault occurs on a line, the relay on either side of the line may refuse to trip because of hidden failure—i.e., it fails to clear the fault. Then all of the exposed lines have to be tripped by the backup protection. “Unwanted tripping” refers to either spontaneous operation in the absence of a fault or a trip on faults outside the protection zone. Both failure modes will worsen the impact of faults on power systems and may cause cascading failure. Although the

probability of hidden failure is rare, if it occurs, the impact on the system is catastrophic. As we mentioned before, these hidden failures are random and remain undetected, so it is difficult to detect them using traditional analysis methods.

3.2 Design of Sequential Monte Carlo Simulation

3.2.1 Monte Carlo Simulation Model

The research of blackout is to identify uncertainties and potential threats of future operating conditions in power system planning and operation and usually require sophisticated mathematical models. The modeling approaches can be classified as analytical or Monte Carlo Simulation [38].

Analytical models have several attractive features: they are accurate, computationally efficient and, perhaps most important, they provide the planner with insights on the relationships between input variables and final results. Their major limitations are related to the simplifying assumptions which may be required for analytical tractability [39].

Among the advantages of the Monte Carlo Simulations (MSC), conceptual simplicity and flexibility are the most important. Conceptual simplicity means each sampled scenario can be seen as a possible ‘history’ of system operation. Flexibility means it is easy to incorporate complex modeling features. The disadvantage of MSC is related to the computational effort, which increases quadratically with the required accuracy of the estimates [40, 41].

This dissertation utilizes the sequential Monte Carlo simulation for the vulnerability analysis of a power system. In the model, it is assumed that each

component in the system (including transmission lines, protection relays, and weather condition) has at least two states (normal state—up, and faulty state—down) and maybe more [42]. These components stay in one of these states randomly according to their failure and repair rates.

When a fault occurs on the system, we first calculate the short circuit current and bus voltage and derive the impedance seen by the relay. If the value is less than the protection relay's setting value, it will trip the related breaker, and the fault will be cleared. In the mean time, we have to check the state of the protection relay. If the protection system is in a "hidden failure" state, we must derive the probability of hidden failure. First, we check the state of the relays on the faulted line. If the relays are in the state of "refuse to trip," we trip all of the exposed lines and continue to calculate the post-fault currents. If the fault is correctly cleared by the protection system, we still need to check the state of the relays on the exposed lines [17, 20]. Each line has its own probability of incorrect tripping, as illustrated in Fig. 3.2 [21]. The model shows the probability of the exposed line tripping incorrectly as a function of the impedance seen by the relay. That the impedance is dependent upon the current system operating state implies that it can be calculated after each topology change.

If a hidden failure occurs, ("unwanted tripping," or tripping of the exposed lines is caused by "refuse to trip"), we need to calculate the post-fault power flow. Because tripped lines may cause loss of load or generator, we need to consider AGC that will act automatically and redistribute the generation according to frequency difference.

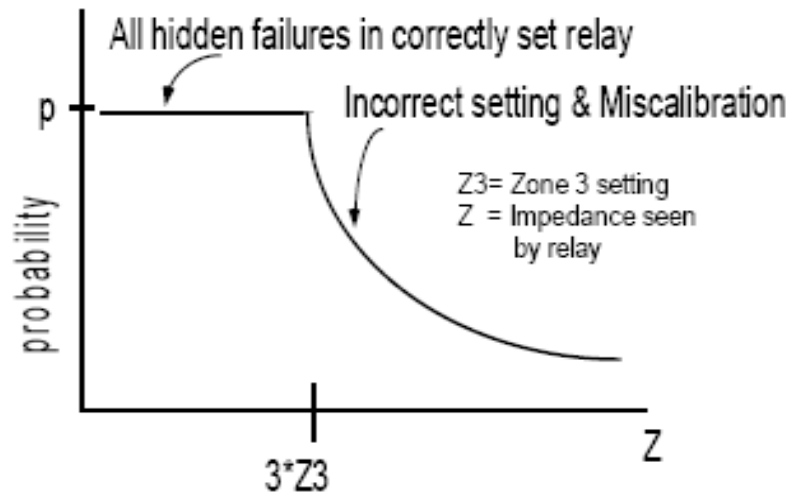

Figure 3.2 Probability of hidden failure

Because those newly tripped lines change the topology of the power system, power flows in the system change accordingly. We also need to calculate the branch currents seen by the over-current protection relay. If they are higher than the relay's setting value, the protection system will also act and trip the corresponding line. If all of the currents are below the setting value, we need to check the state of the relays on those new exposed lines, and if they are in the "hidden failure" state we need to calculate the probability of "unwanted tripping" again. This time, the probability of "unwanted tripping" is the function of current seen by the over-current protection relay [18].

3.2.2 Flowchart of Sequential Monte Carlo Simulation

Sequential Monte Carlo simulation is flexible enough to incorporate dependent failures, and thus it is suitable for large, complex systems. In addition, sequential Monte Carlo simulation can also produce the probability distribution of random variables other than their mean values [21].

There are two approaches for Monte Carlo simulation: sequential simulation and random sampling. The sequential simulation proceeds by generating a sequence of events using random numbers and probability distributions of random variables defined as component state durations. In addition, there are two methods of representing the duration of time in sequential simulations: the fixed-interval method, also called synchronous timing, and the next-event or asynchronous timing method. In the fixed-interval method, time is advanced in steps of fixed length, and the system state is updated at each step. In the next-event method, time is advanced until the occurrence of the next event. In this dissertation, the next-event sequential method is used to simulate power system blackouts.

3.2.2.1 Description of the Proposed Approach

The time to the next event is generated by using the inverse of probability distribution method. This is achieved by drawing a random number between 0 and 1 and then computing the time of next event [22]. As “time” proceeds, we check the component with the minimum random variable and force it to fault, which is defined as the “next event.” If this next event is related to weather, then we need to use the corresponding failure rates of transmission lines. If the next event occurs on a relay, we change the state of the relay and go on to the new next event. If the next event occurs on a transmission line, we check whether the current state of the line is “up”. If the answer is “no”, we change the state of the transmission line to “up” and continue; if the answer is “yes”, then an evaluation of this stage for adequacy and security is performed.

If the next event occurs on a transmission line where the current state is “up”, it means that the line is faulted. Then we check if there is a hidden failure happened on any exposed lines. We calculate the short circuit current of the whole system. Here, we use a short circuit current program to calculate the bus voltage and line current during the fault. Based on these fault parameters, the impedance seen by the relay at each bus can be calculated.

In addition, the relays on “neighborhood” lines (exposed) lines may malfunction with a low probability, which is known as a hidden failure. That means we need to check the state of the relays on these lines. If the state of any of these relays is “down” which means there exists a hidden failure, then the neighbor or exposed line is also out of service. We continue to search if hidden failures exist in the exposed lines of the newly faulted line, and this process continues until a blackout occurs. The Monte Carlo method simulates the occurrences of blackouts until the reliability indices converge.

3.2.2.2 Flowchart of the Sequential Monte Carlo Simulation

Figure 3.3 presents a flowchart of the sequential Monte Carlo simulation. The basic methodology is explained as follows.

1. Set the initial state of all components to be “up”.
2. Find the next event and change the state of the corresponding component, then update total time.
3. If the component is a protective relay, change the state of the relay; If the component is the weather, change the failure rate of all transmission lines; go back to step 3.

4. If the component is a transmission line, calculate the short current of the system and list all exposed lines that are likely to mis-operate.
5. Compute the currents on the exposed lines by conducting a short current calculation.
6. Check the state of the relays for each exposed line after the short circuit current is computed in step 5. If the impedance seen by the relay is less than the set value, trip the line; if state of the corresponding relay is “down,” calculate the probability of incorrect tripping.
7. Determine the number of lines that will trip.
8. Cut the tripped lines and run AGC. Update the list of exposed lines based on newly tripped lines.
9. If new lines trip, go to step 6.
10. Record the cascading outages.
11. Calculate the reduced admittance matrix (including load) of each state of the system. Use the integration method to solve the differential equations and obtain the dynamic state of generator angle and speed. Check whether the system is stable during the process. If it is not, stop the simulation and go to step 12; if it is, go back to step 2.
12. If a blackout happens, record the total time as the system “up” time. Check whether the reliability indices converge. If yes, stop; Otherwise, go to step 1

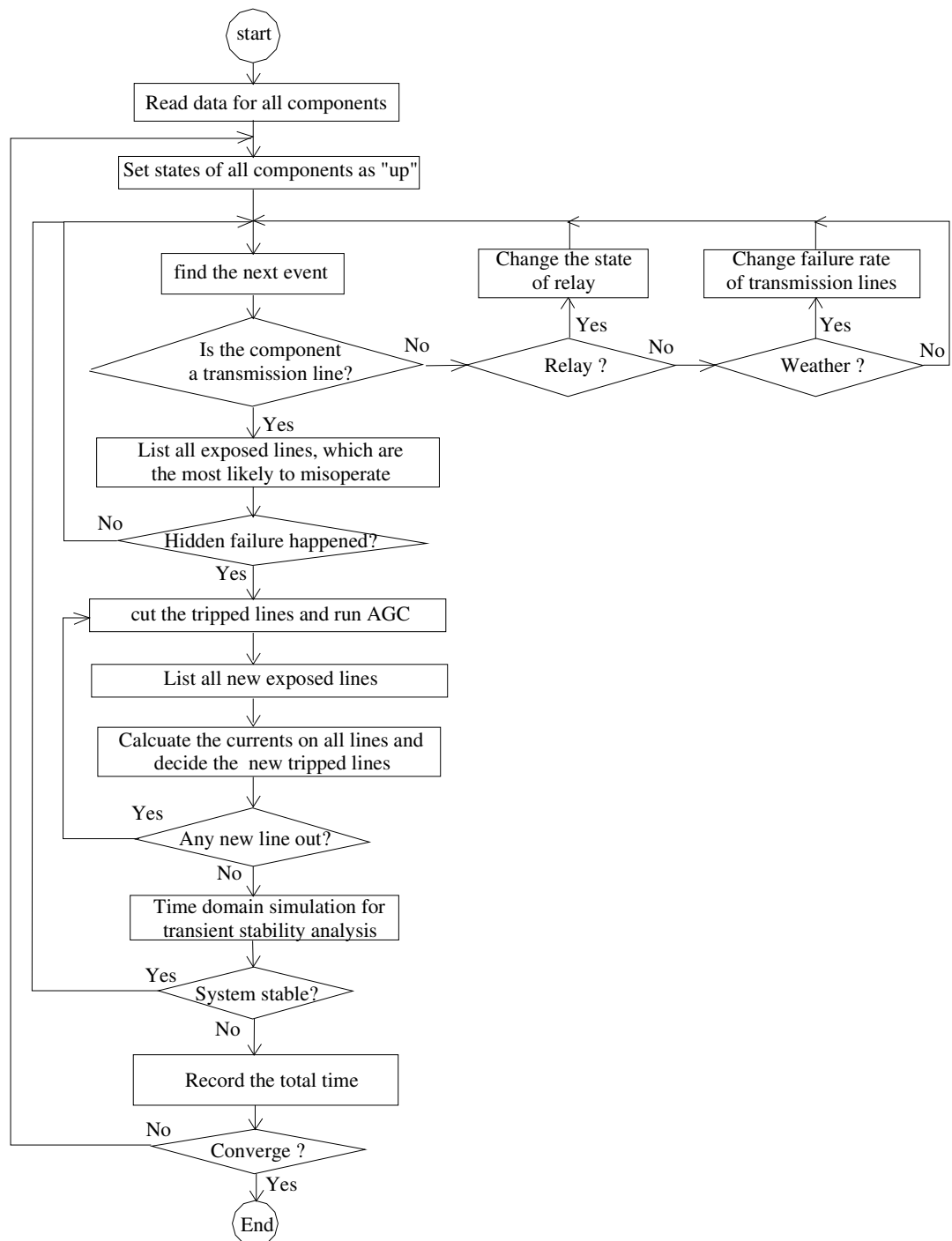

Figure 3.3 Flowchart of sequential MCS for power system

CHAPTER 4
SIMULATION RESULTS AND DATA ANALYSIS

The theory of power system blackouts has been established in Chapter 2 and the power system model has been provided in chapter 3. In this chapter, the developed theory is justified by using Monte Carlo simulation to evaluate the system reliability on the IEEE 24-bus system as shown in Fig. 4.1 and 118-bus system as shown in Fig. 4.2.

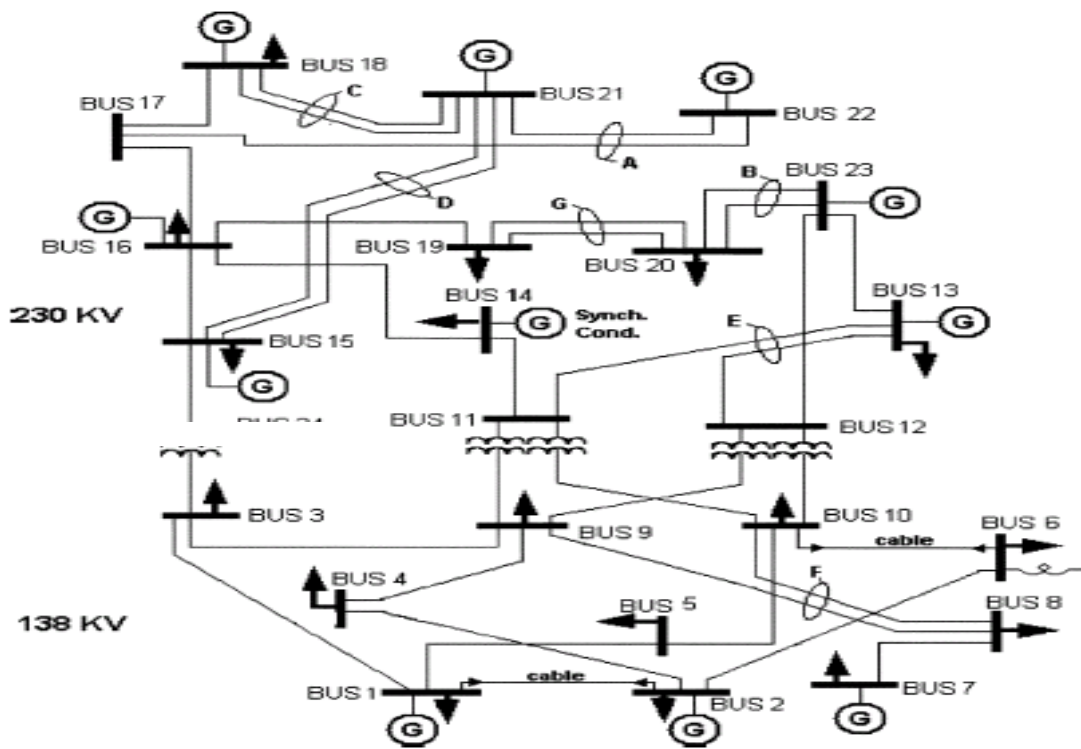

Figure 4.1 IEEE 24-bus system

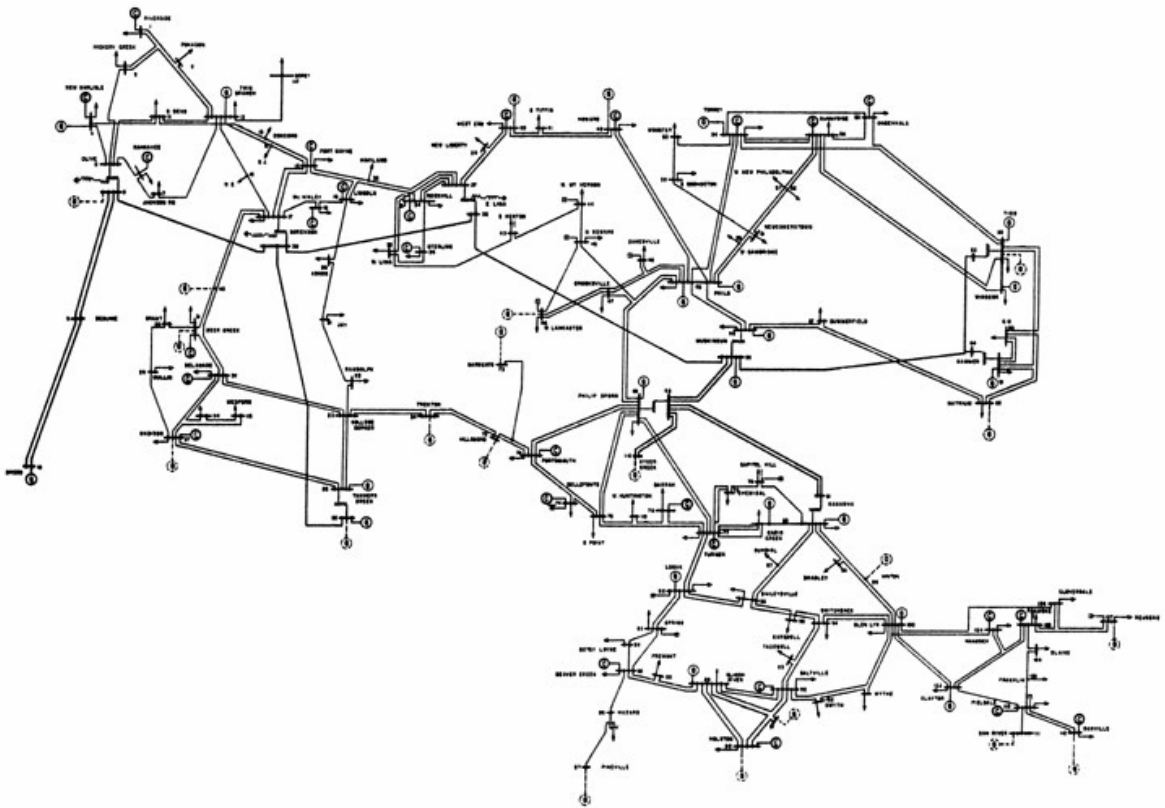

Figure 4.2 IEEE 118-bus system

4.1 Justification of Theory of Power System Blackouts

Monte Carlo simulation was used to evaluate the probability of blackouts on the sample system. The blackouts are defined as cascading failures causing loss of load of more than a specific amount (e.g. half of the total load). The flowchart of Monte Carlo simulation is given in Figure 3.3.

Let $W_1 = \min(X_1, \dots, X_n)$. Then Theorem 1 states that W_1 follows an exponential distribution. The simulated results and theoretical results match very well in Fig. 4.3.

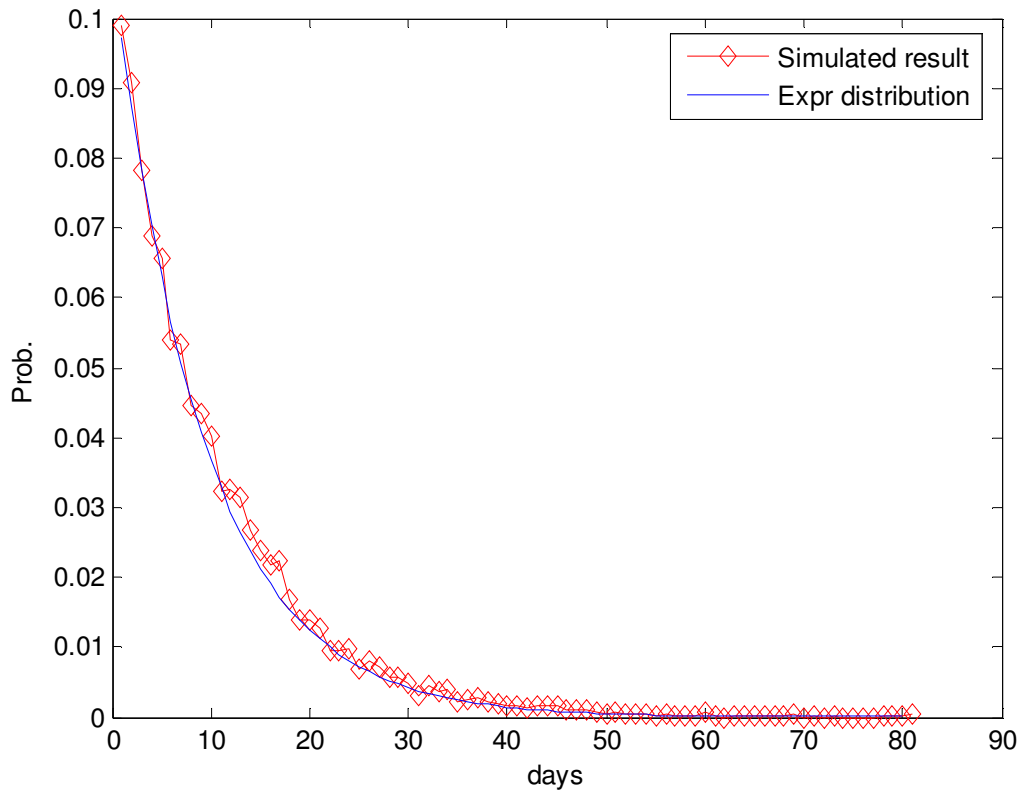

Figure 4.3 Justification of Theorem 1

Theorem 2 indicates that the sequence $(X_1 - W_1, X_2 - W_1, \dots, X_{T-1} - W_1, U, X_{T+1} - W_1, \dots, X_n - W_1)$ has the same exponential distribution as the original sequence (X_1, X_2, \dots, X_n) , which is shown in Fig. 4.4.

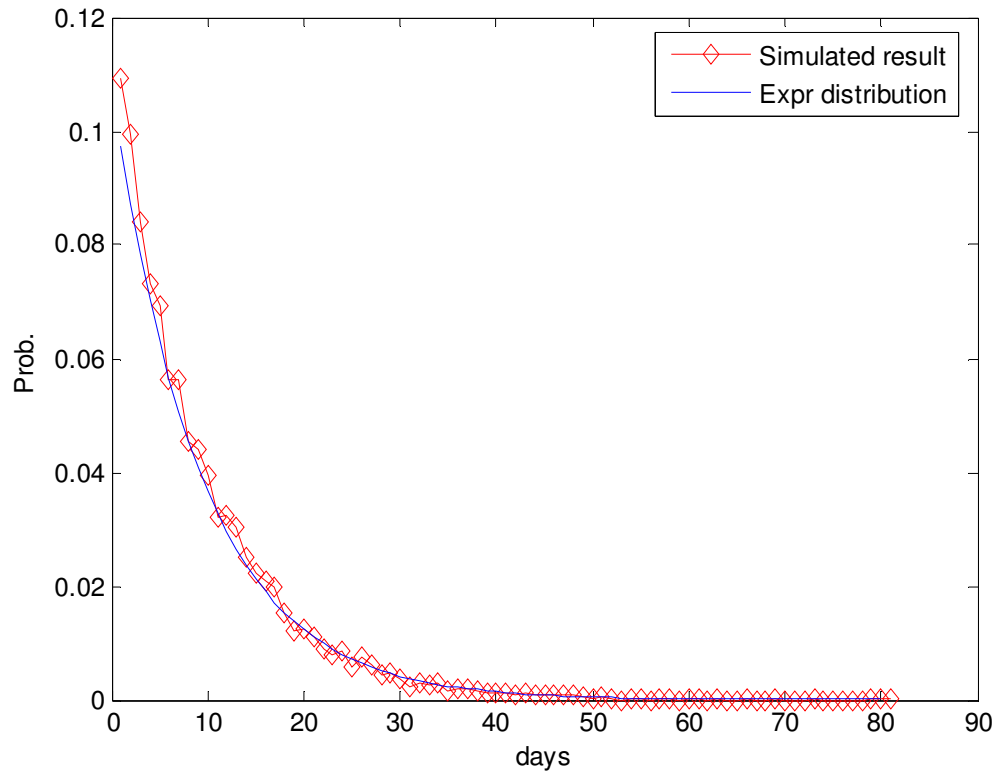

Figure 4.4 Justification of Theorem 2

Theorem 3 states that the distribution of blackouts due to the PrimaryCause¹ can be best approximated by a Gamma distribution. Fig. 4.5 shows the approximation of a Gamma distribution compared with the distribution of blackouts due to the PrimaryCause¹.

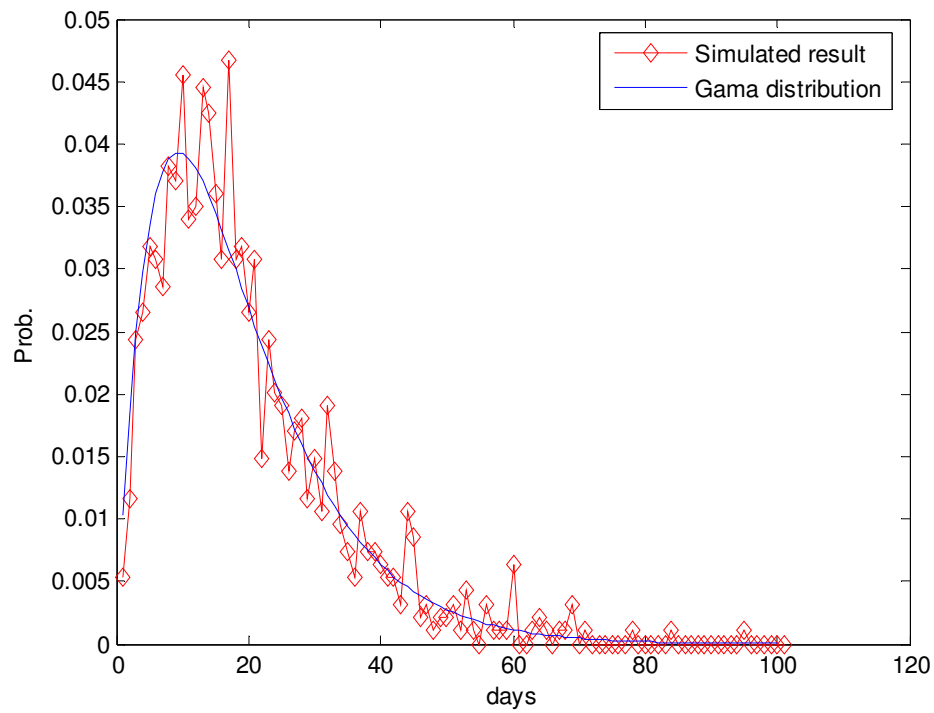

Figure 4.5 Justification of Theorem 3

Theorem 4 predicts that the PrimaryCause¹ defined in Fig. 2.1, which does not cause any blackouts, follows an exponential distribution. Fig. 4.6 shows that the theoretical results fit the simulated results very well.

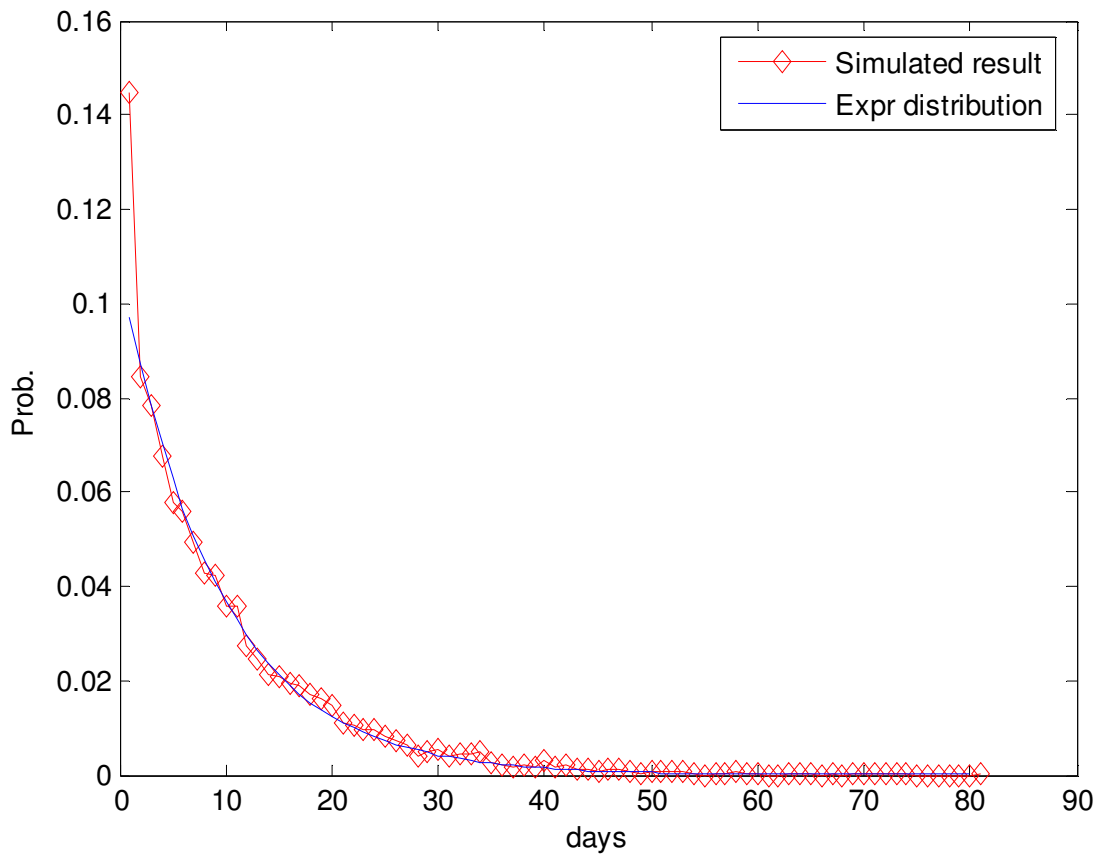

Figure 4.6 Justification of Theorem 4

In Chapter 2 we have shown that the PrimaryCause^2 defined in Fig. 2.1 approximately follows a Gamma distribution, which is shown to be correct in Fig. 4.7.

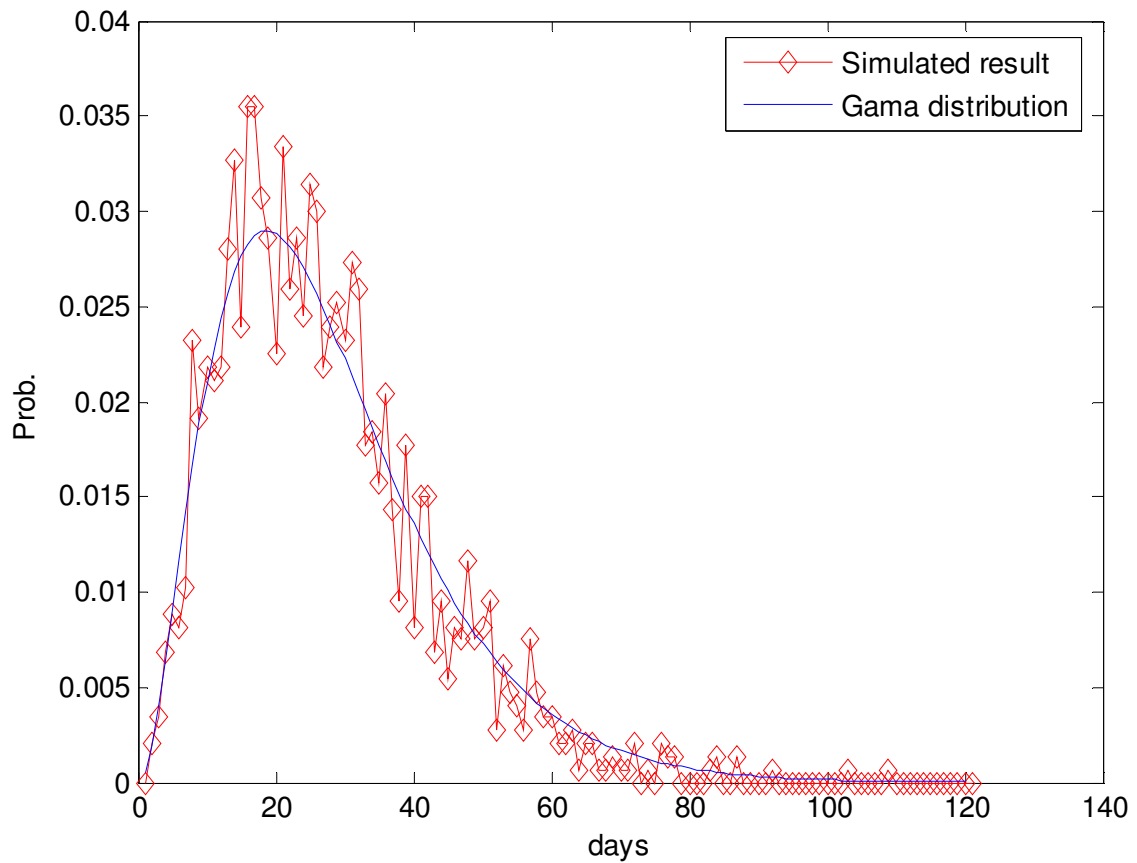

Figure 4.7 Comparison between the simulated results and theoretical results(primary Cause²)

In chapter 2 we also show that a high level of PrimaryCause follows a Gamma distribution. From Fig. 4.8 we can see the simulated result is quite close to the theoretical results (the level is the 5th PrimaryCause).

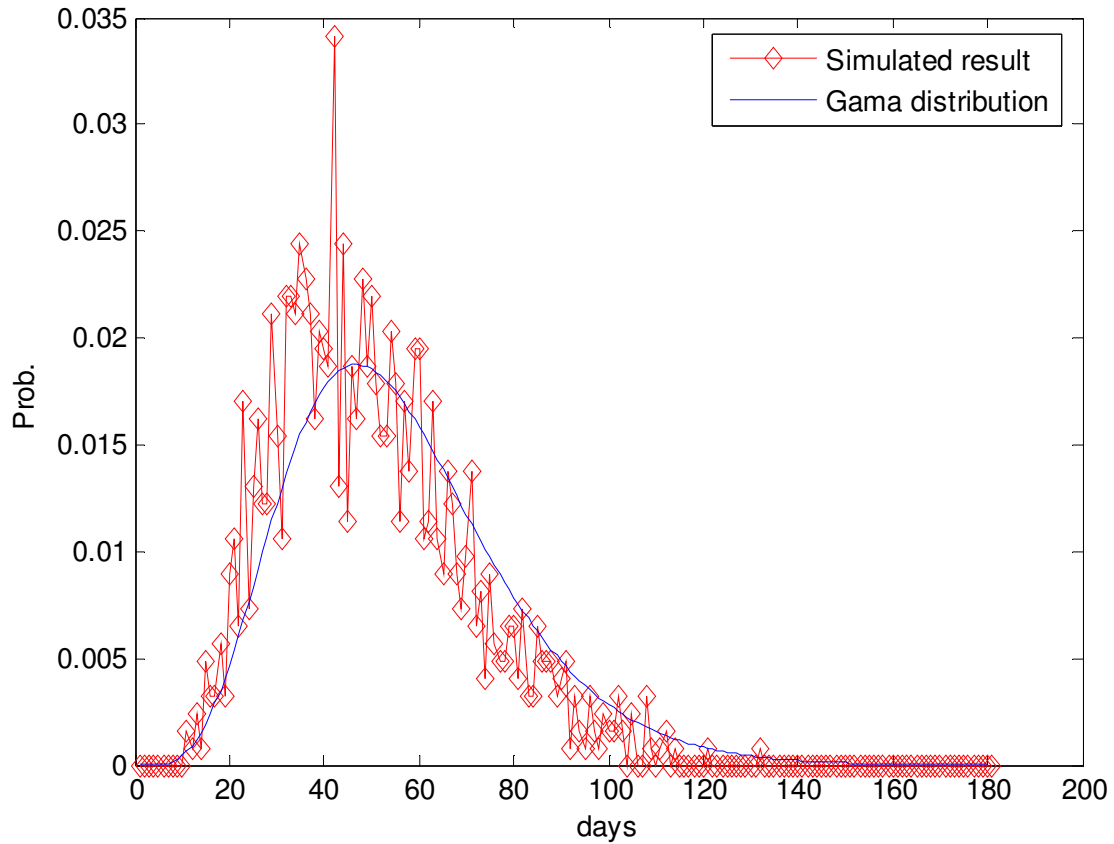

Figure 4.8 Comparison between the simulated results and the theoretical results(primary Cause⁵)

In order to verify the validity of Eqs. (2.2) and (2.3) proposed in chapter 2, we compared the distribution of blackouts by simulation and the distribution given by Eqs. (2.2) and (2.3). It is obvious that they match very well. Table 4.1 shows the parameters of different level:

Table 4.1 Parameters of different levels

| level | π_i | α_i | β_i |
|-------|----------|------------|-----------|
| 1 | 0.097478 | 2.01386 | 9.42067 |
| 2 | 0.15154 | 3.07524 | 8.64484 |
| 3 | 0.155778 | 4.04637 | 8.69919 |
| 4 | 0.145028 | 5.32661 | 7.90419 |
| 5 | 0.127248 | 6.01114 | 8.20967 |
| 6 | 0.098305 | 6.8406 | 8.31662 |
| 7 | 0.070912 | 7.92446 | 7.88942 |
| 8 | 0.053132 | 8.59431 | 7.97153 |
| 9 | 0.034422 | 10.0114 | 7.51307 |
| 10 | 0.02729 | 9.86875 | 8.30997 |
| 11 | 0.014368 | 11.0348 | 7.90556 |
| 12 | 0.00951 | 12.4654 | 8.04218 |
| 13 | 0.006719 | 12.6747 | 8.03688 |
| 14 | 0.002998 | 14.1883 | 7.56589 |
| 15 | 0.001757 | 15.4362 | 7.11447 |
| 16 | 0.001654 | 20.4018 | 5.72375 |
| 17 | 0.001137 | 62.369 | 1.96046 |
| 18 | 0.000207 | * | * |
| 19 | 0.000103 | * | * |
| 20 | 0.00031 | * | * |
| 21 | 0 | * | * |
| 22 | 0.000103 | * | * |
| 23 | 0 | * | * |

* the parameter can't be calculated because the number of samples is too less.

4.2 System Result and Data Analysis

In Chapter 2 It is proved that the blackout of power system satisfy a mixture Gamma distribution. The density function is:

$$f(x) = \sum_{k=1}^{K_0} p_k f_{k,\beta}(x), \quad x \geq 0. \quad (4.1)$$

where

$$f_{k,\beta}(x) \sim \text{Gamma}(k, \beta)$$

To verify the validity of Eqs. (4.1), we compared the distribution of blackouts by simulation and the distribution deduced from our theorem. Figure 4.9 and Figure 4.10 show that they match very well.

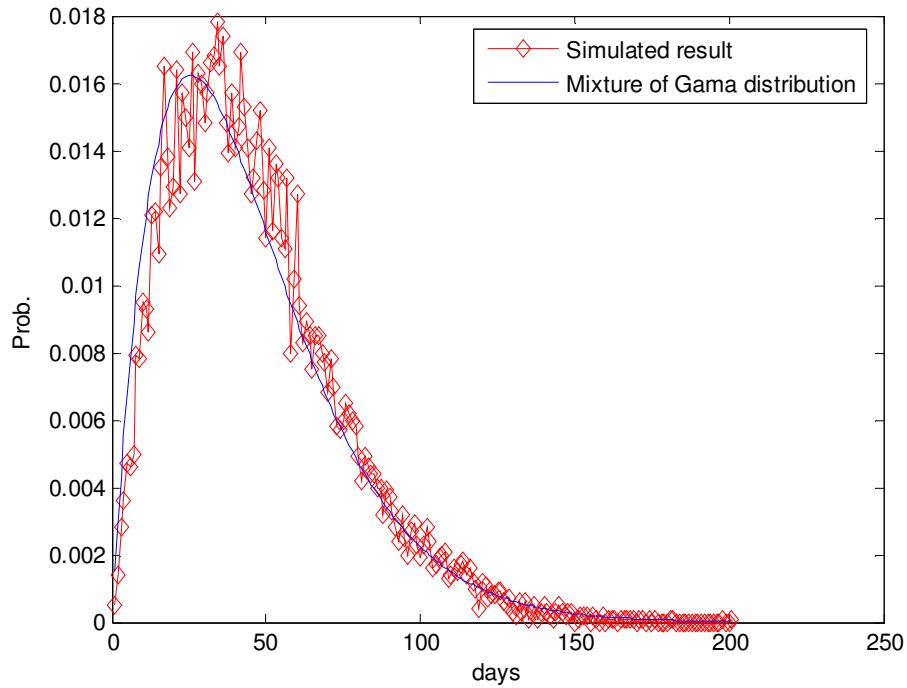

Figure 4.9 Comparison between the simulated blackout distribution and the theoretical distribution of blackouts (24-bus system)

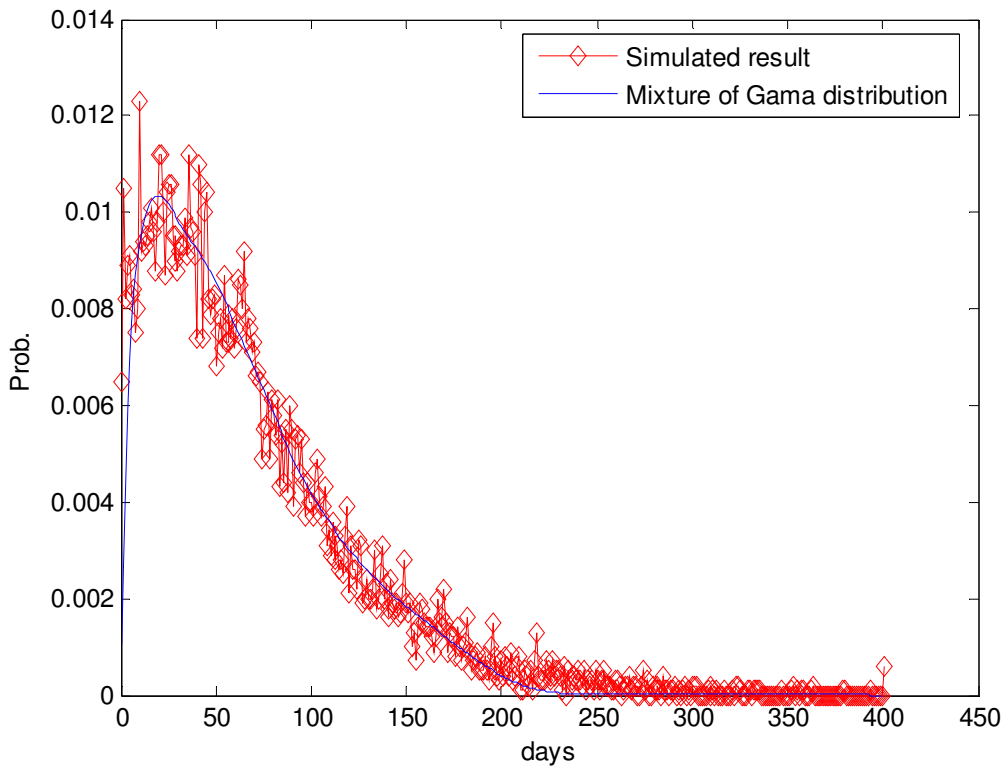

Figure 4.10 Comparison between the simulated blackout distribution and the theoretical distribution of blackouts (118-bus system)

In our simulation, we get 10,000 samples for each system. We find the main reason for blackouts are overload, frequency deviation, and transient stability. Table 4.2 shows the detail for both systems.

Table 4.2 Comparison of 24-bus system with 118-bus system (10,000samples)

| | 24-bus system | 118-bus system |
|-------------------------------|---------------|----------------|
| Total Load (MW) | 2850 | 3803 |
| Generators | 11 | 54 |
| Loads | 17 | 91 |
| Mean time (days) | 53.8 | 68 |
| β | 360/38 | 360/186 |
| Voltage instability (times) | 552 | 1406 |
| Frequency instability (times) | 1940 | 7570 |
| Transient instability (times) | 7498 | 1024 |

Several points of observation from Table 4.2:

- Although the load of 118-bus system is heavier than the 24-bus, it is still more reliable than the later (its mean time is 68days, longer than 53.8days of 24-bus system). So interconnection will increase the reliability of power system.
- For 24-bus system, most blackouts happen because of transient stability problem (7498 times). But for 118-bus system, it is different. Frequency deviation is the main reason that causes system blackouts (7570times). This shows that the reason of blackout for different system is different.
- The β value of 118-bus system ($360/186=1.935$) is much smaller than that of 24-bus system ($360/38=9.473$). But the distribution of P_i is also different (as shown in the Figure 4.11). For 24-bus system, P_i focuses on $i=3\sim 5$ (see Table 4.1). For 118

system, P_i focuses on $i=9\sim 16$. So the mean life time of 118-bus system is still longer than 24-bus system.

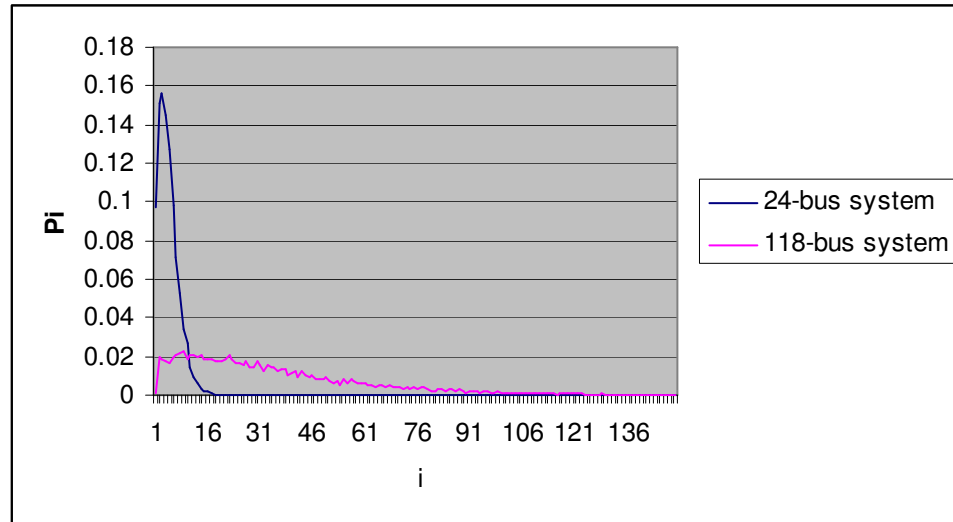

Figure 4.11 The P_i comparison of 24-bus system with 118-bus system

Through above analysis, we know the blackout of power system satisfy a mixture Gamma distribution. And β depends only on the failure rate of transmission lines. If we assume each line has the same failure rate λ , then β is λ/nb . nb is the number of transmission lines in the system. P_i depends on many factors, e.g. hidden failures, human errors, etc. They are the only parameters we need to estimate.

Figure 4.12 shows the 1000 samples' curve and the estimated curve

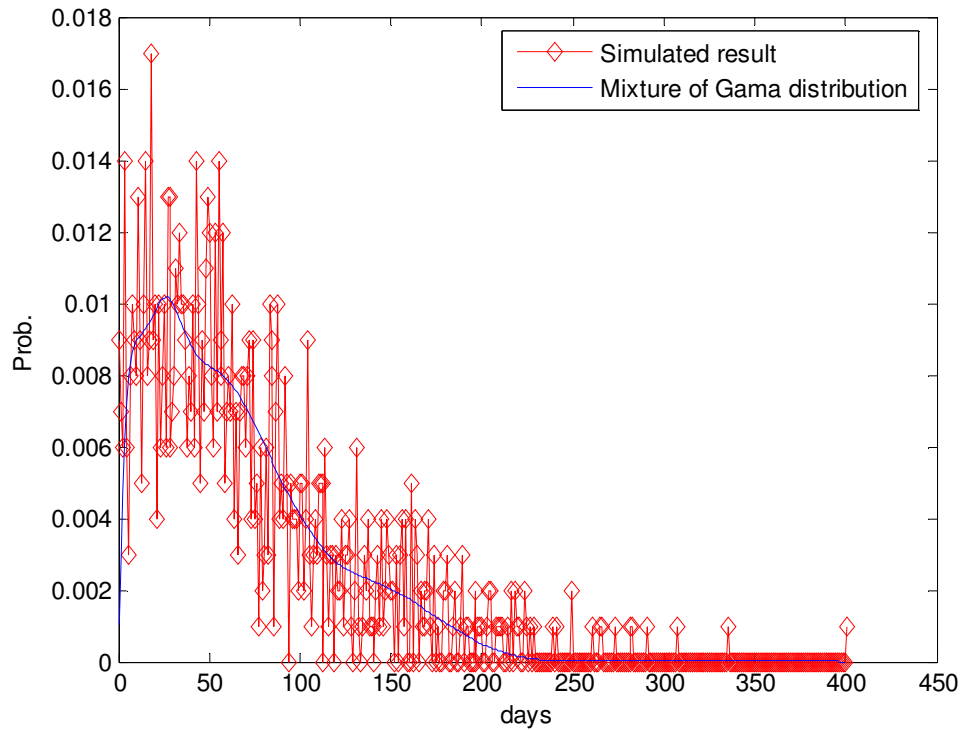

Figure 4.12 Comparison between the simulated blackout distribution and the theoretical distribution of blackouts (118-bus system, 1000 samples)

For Figure 4.12, if we use traditional method to estimate the distribution of system blackout (that is using red curve to estimate), we find 1000 samples are not enough for 118-bus system.

Now we know the distribution of blackouts satisfy mixture Gamma distribution. We could use these 1000 samples to estimate P_i first, then using Eq 4.1 to estimate the power system blackout distribution (as shown in blue curve).

Figure 4.13 shows the curve we deduced from 1000 samples already match quite well with simulated result of 10,000 samples. So the new method could greatly reduce the number of samples required.

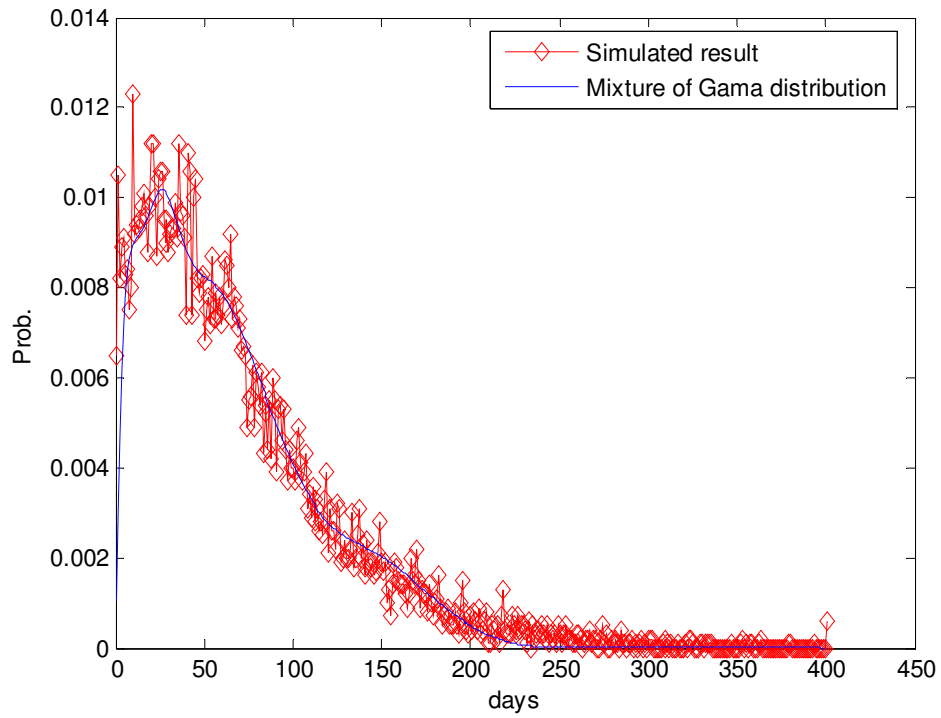

Figure 4.13 Comparison between the simulated blackout distribution (10,000samples) and the theoretical distribution of blackouts (parameters deduced from1000samples).

CHAPTER 5

DISTRIBUTION SYSTEM RELIABILITY ANALYSIS

Reliability is one of the most important subjects in distribution system operation and planning due to its high impact on the cost of electricity and its high correlation with customer satisfaction [43, 44]. System reliability can be improved by reducing the frequency of occurrence of faults and reducing the repair time by means of various design and maintenance strategies [45].

In an increasingly competitive market environment, there are consents among distribution system planners and operators regarding numerical evaluation of reliability cost. Actually, electrical utilities have been continuously investing on infrastructure improvement to satisfy the growing demand on reliability. Since customers' outage costs are different, their desired levels of reliability are also different. Building more facilities definitely could improve the whole distribution system's reliability, but the amount of improvement for different customers varies. It is therefore important to objectively assess the cost benefits of the projects. Reliability targets should be based on a customer's needs and the willingness to pay for a desired level of reliability so that the total cost (power supply cost plus customer outage costs) is minimized [46].

Thus, two sets of reliability indices—customer load point indices and system indices—should be established to assess the reliability performance of distribution

systems. Load point indices measure the expected number of outages and their duration for individual customers. System indices such as the System Average Interruption Duration Index (SAIDI) and the System Average Interruption Frequency Index (SAIFI) measure the overall reliability of the system [47].

There are two common approaches to distribution system reliability evaluation—analytical enumeration and Monte Carlo simulation [48-51]. Analytical approaches are efficient and should always be employed (1) when it is possible to develop models that can reasonably represent the physical systems, and (2) when such models are amenable to solution. Some problems are, however, too complex to be solved in this manner. Monte Carlo methods are generally more flexible when there is a need to incorporate complex operating conditions and system considerations such as multi-derated states, chronology, reservoir operating rules, bus load uncertainty, weather effects, etc.

But this method usually requires a larger investment in computing time and effort compared with analytical method. So in our program we also develop a distributed computing algorithm to save computing time (see chapter 6 for detail).

Our Distribution System Reliability Evaluation (DSRE) program written in Matlab is Windows based and has a very friendly interface. It calculates not only each feeder's SAIFI and SIADI but also the SAIFI and SAIDI of each customer.

Our program has been tested on Oncor's three feeders. The results show that our simulations match quite well with the historical record of reliability indexes.

5.1 Component Modeling

Feeders of distribution systems deliver power from distribution substations to customers. A feeder normally begins with a feeder breaker at the substation point, and the main components of a feeder include lines, poles, a breaker, switches and fuses, transformers, and capacitors [53-55].

1) Lines:

Lines can be broadly categorized into overhead lines and underground cables, which have different failure rates. If any line fails, the failure is assumed to be a short circuit fault, which will cause the corresponding switch or fuse to open.

2) Poles:

Poles support overhead distribution equipment and are an important part of overhead lines. Different types of poles are defined. A pole should at least be composed of two parts—an insulator and the pole itself—but for some three-phase lines a crossarm is also necessary. Some poles are used to connect between an overhead line and a cable or to connect several lines. This type of pole is composed of six parts: in addition to the crossarm, the insulator, the pole itself, a connector, an arrester, and a jumper. If any part of the pole fails, the entire pole fails. Then the lines connected to the pole are assumed to be short circuited except the jumper fails. Jumper failures have two types: short circuit or open circuit. If it is open, then it only means that the load side line is cut. Therefore no switch or fuse will trip.

3) Switches and Fuses:

Switches and fuses are used to isolate the faulted section. Usually, switches do not have fault-interrupting capability because when a switch is designed to isolate a fault, a breaker has to be opened to cut the fault current before the switch operates. All customers connected to the feeder will lose power after the breaker is open, and then the system will open the switch and close the breaker at the same time. If a fuse is overloaded, the breaker will not open unless the fuse fails to blow.

A fuse is a typical protection device designed to improve a distribution system's reliability, especially for radial branches. Both field experience and reliability studies show conclusively that laterals should be fused. The problems with fuses are nuisance fuse blowing and the inability to coordinate.

Sectionalizing switches have the potential to improve reliability by allowing faults to be isolated and customer service to be restored before the fault is cleared. The effectiveness of this process depends upon how much of the feeder must be switched out to isolate the fault and the capability of the system to reroute power to interrupted customers via normally open tie points. Generally, more manual, normally closed and normally open switches will result in reduced SAIDI but will not impact SAIFI. However, placing more switches on a feeder will not always improve the feeder's reliability because each switch has a probability of failure.

Automated switches are also considered in our program. An "automated switch" usually refers to a switch that can automatically open and close after a fault occurs. Automated switches can isolate a fault and re-configure the distribution system with the help of some communication equipment. Since the automated switches can be opened

and closed quicker than manual switches, their reliability impact on a distribution system is significant.

4) Capacitors:

Capacitors are used to provide reactive currents to counteract inductive loads. Typical distribution systems use fixed capacitors that are connected to feeders. Capacitor failure means that the line to which it is connected is short-circuited, which in turn trips the corresponding switch or fuse.

5) Transformers:

Distribution system transformers transfer the voltage to the customer levels and are usually classified as pole-mounted transformers (for overhead feeders) or pad-mounted transformers (for underground cables). They can be single phase or three phase transformers, and they usually have over-current and lighting protections.

Some distribution systems also include reclosers and sectionalizers, which are used to avoid the impact of temporary faults on distribution system power supplies. Because Oncor does not have this equipment in its three feeders, we will not discuss these models here.

5.2 System Modeling

A distribution system consists of thousands of components such as transformers, overhead lines, underground cables, fuses, sectionalizing switches, and poles. These components are the building blocks that can be assembled in a myriad of ways to create a wide variety of distribution systems with unique characteristics.

From a reliability perspective, nearly all of the information needed to create a distribution system model is contained in the distribution component information—a highly desirable feature. Given a palette of components, systems can be constructed from scratch by choosing components and connecting them together. Once a system model is created, modifications can easily be made by adding components, removing components, or modifying component characteristics.

5.2.1 Component Reliability Parameters

Needless to say, component models are critical to distribution system reliability. A component model should be as simple as possible but needs to capture all of the features critical to system reliability. Each distribution system component can be described by a set of reliability parameters, and we will now provide a detailed description of some the parameters used in our program.

Permanent Short-Circuit Failure Rate (λ_p) — λ_p describes the number of times per year that a component can expect to experience a permanent short circuit. This type of failure causes fault current to flow, requires the protection system to operate, and requires a crew to be dispatched for the fault to be repaired.

Temporary Short Circuit Failure Rate (λ_T) — λ_T describes the number of times per year that a component can expect to experience a temporary short circuit. This type of failure causes fault current to flow but will clear itself if the circuit is de-energized (allowing the arc to de-ionize) and re-energized. According to Oncor, temporary faults will not be considered in our program.

Mean Time To Repair (MTTR) represents the expected time it takes for a failure to be repaired (measured from the time that the failures occurs). A single MTTR is typically used for each component, but separate values can be used for different failure modes. In our program, a default MTTR is assigned for each component.

Probability of Operational Failure (POF) is the conditional probability that a device will not operate when it is supposed to operate. For example, if an automated switch fails to function properly 5 times out of every 100 attempted operations, it has a POF of 5%. This reliability parameter is typically associated with switching devices and protection devices.

All of the above-mentioned reliability parameters are important, but component failure rates have historically received the most attention.

5.2.2 Failure Rates and Bathtub Curves

It is typical to model component reliability parameters using a single scalar value. For example, an insulator might be modeled with a failure rate of 0.02 per year. However, the failure rates of certain components tend to vary with age. New installed electrical equipment may have manufacturing flaws, may have been damaged during shipment or installation, or may have been installed incorrectly. This period of high failure rate is referred to as the infant mortality period or the equipment break-in period. A graph that is commonly used to represent how a component's failure rate changes with time is known as a bathtub curve (as shown in Figure 5.1). The bathtub curve begins with a high failure rate (infant mortality), decreases to a constant failure rate (useful life), and then increases again (wearout).

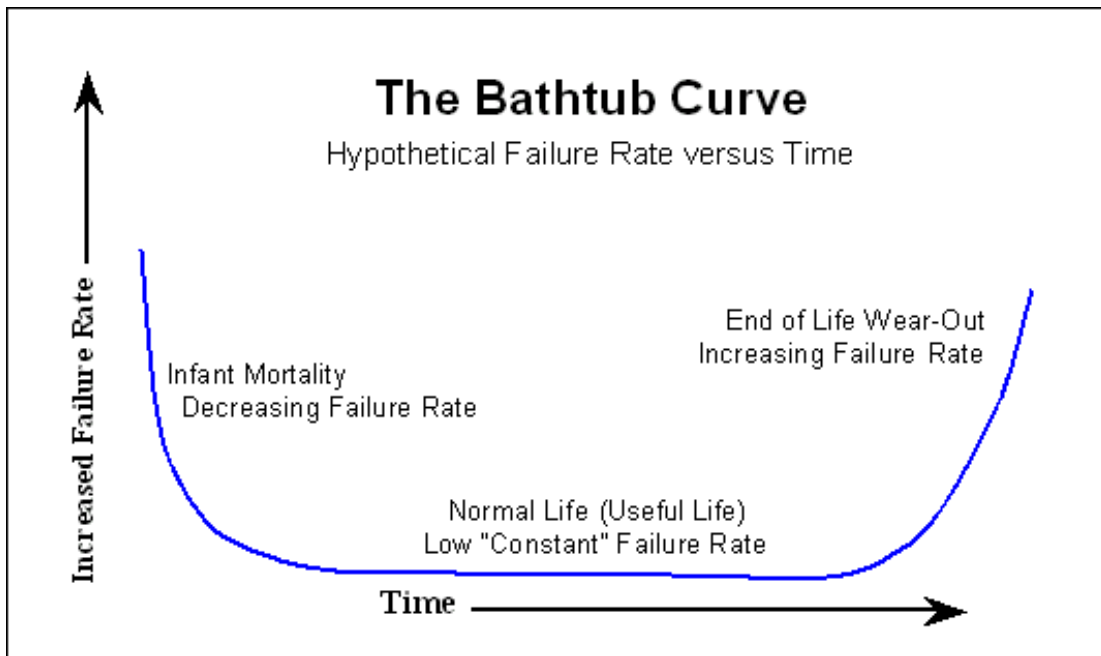

Figure 5.1 The Bathtub Curve

A more detailed curve used to represent a component's hazard function is the sawtooth bathtub curve (as shown in Figure 5.2). Instead of using a constant failure rate in the useful life period, this curve uses an increasing failure rate. The increase is attributed to normal wear and can be mitigated by periodic maintenance.

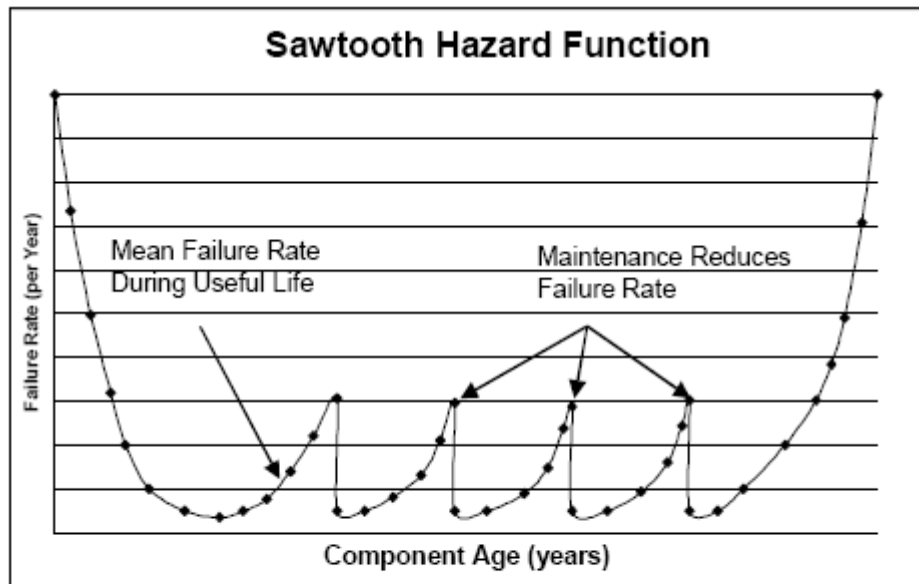

Figure 5.2 Component Failure Rate Curve versus Time

In our program, we just consider the failure rate as a constant λ . The reasons are as follows:

- The bathtub curve is very difficult to obtain in the real world. The effect of maintenance on failure rate is even harder to provide by user.
- Normally, the useful life of equipment used in distribution systems is very long. The infant mortality or break-in period is quite short compared with useful life. So it can be ignored.

5.2.3 Probability Distribution Functions

Probability distribution functions are mathematical equations allowing a large amount of information, characteristics, and behavior to be described by a small number of parameters. The most often used are the exponential, Weibull, gamma, normal, lognormal, and Poission distributions. In our program, we use exponential distribution.

The exponential distribution is the most common distribution function used in the field of reliability analysis because it is characterized by a constant failure rate, which fits the profile of electrical components during their useful life. A further advantage of the exponential distributions is that it is fully characterized by a single parameter, λ .

5.2.4 Reliability Data

The following reliability parameters are used for the distribution system. We approximate all the feeders with the same parameter.

Table 5.1 Reliability Data of Distribution System

| | (%/per year) | MTTR (hour) |
|-------------------|--------------|-------------|
| Overhead line | 1.58 * | 3.58 |
| Underground cable | 17.06* | 3.66 |
| Pole | 0.02 | 5.27 |
| Insulator | 0.0038 | 2.19 |
| Crossarm | 0.0071 | 2.89 |
| Connector | 0.24 | 1.67 |
| Arrestor | 4.21 | 1.60 |
| jumper | 0.0768 | 2.26 |
| Capacitor | 0.22 | 1.44 |
| Fuse | 0.0038 | 2.03 |

* Failure rates for lines are per circuit mile.

5.3 Monte Carlo Simulation

In Monte Carlo simulation, a stochastic process is simulated many times over a finite period of time in order to determine its characteristics from observations. The

Monte Carlo method is flexible enough to model any complex systems and their complicated operations.

5.3.1 Radial Structure

Most distribution systems, although highly interconnected, are connected radially by selectively choosing normally open points. A radial distribution system is defined as a system in which each component has a unique path to a source of energy. Thus, we can define a relation function for each component.

Radial structures are often referred to as trees, with the source of power being the root of the tree and the components being nodes of the tree. Figure 5.3 shows a simple radial power distribution system.

Line 2 is the unique source power for lines 3 and 10, so we will define line 2 as the father line of lines 3 and 10. Because of radial topology, we can form a relation function: $F(n)$. For example, $F(2) = 1$; $F(12) = 10$; $F(11) = 10$. Notice that $F(1)$ is a substation. Thus, the impact of any component's failure on the distribution system's reliability assessment can be easily deduced from this simple function.

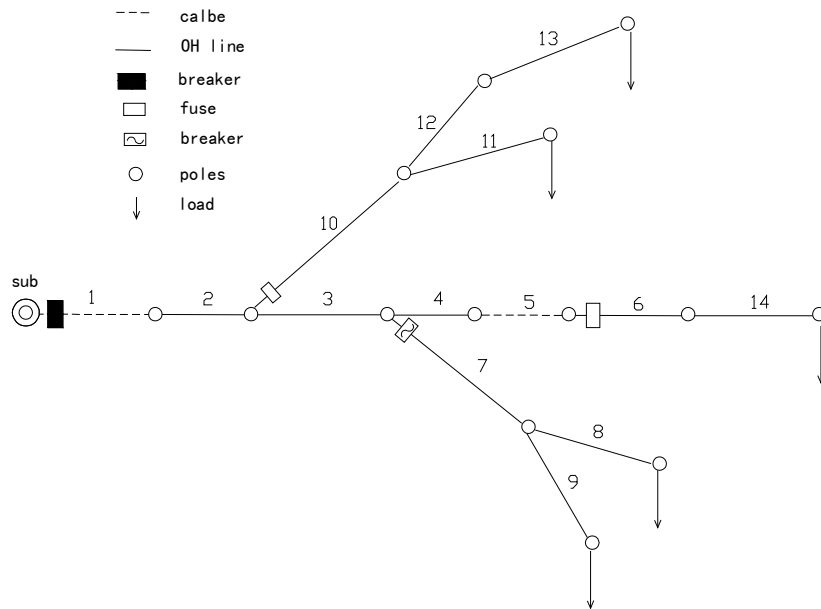

Figure 5.3 Example of a distribution feeder

For example, if a fault happens on line 13, we need to find which switch/fuse or breaker will trip. Because line 13 does not have switch or fuse, we need to trace upstream to find the nearest switch or fuse. Using relation function $F(n)$, we know that $F(13) = 12$, but when we check line 12 there is still no switch or fuse. If we continue to check $F(12) = 10$, we find that a switch is installed on line 10. However, this switch cannot trip the fault current, so we must trace further along upstream until we find the breaker. After the breaker trips, the switch will open to isolate the fault, and after the fault has been isolated the breaker will close and continue to supply power to the other customers. Then all of the customers who are not connected to the source will lose power during the above process. A flow chart of the upstream tracing process is shown in Figure 5.4.

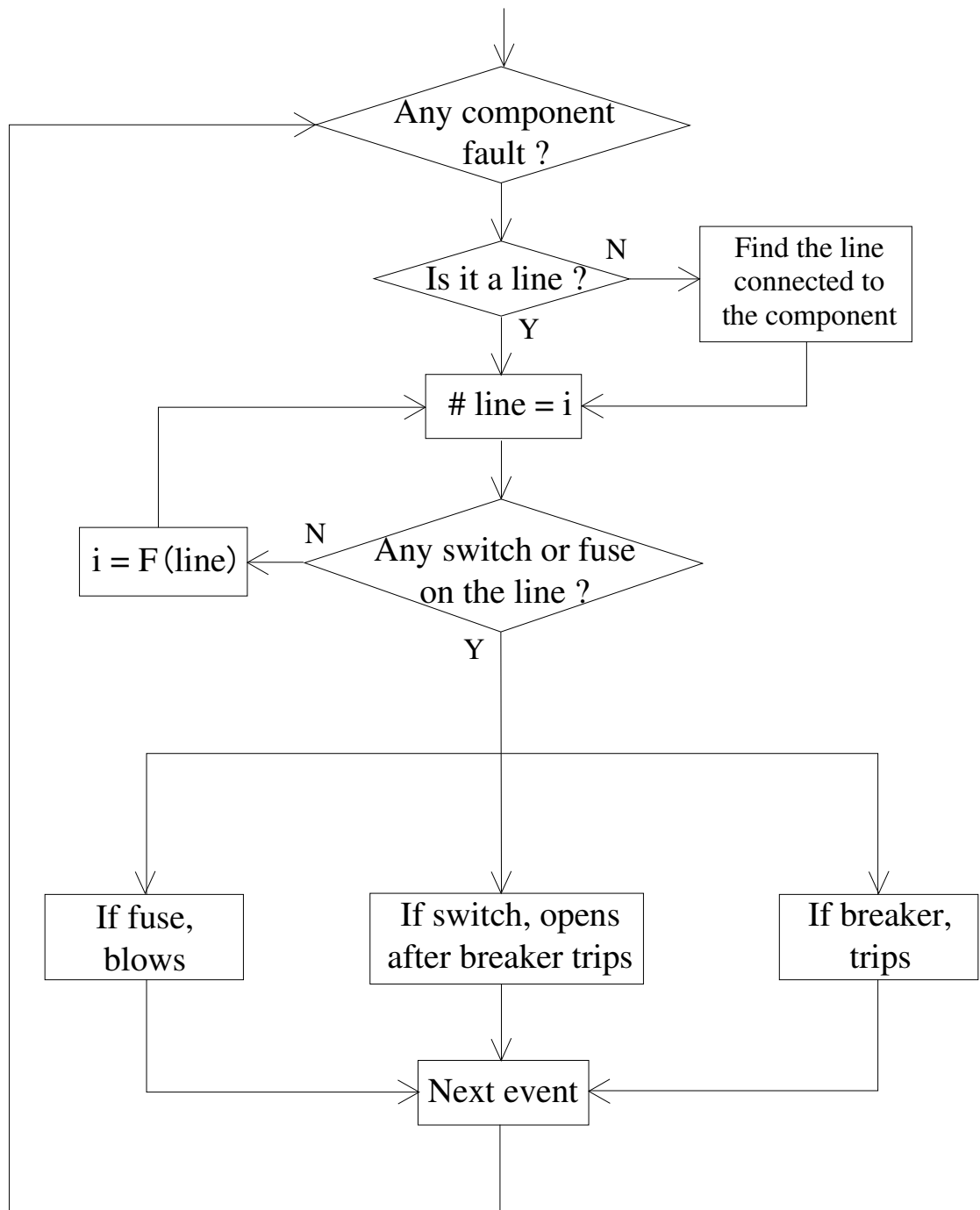

Figure 5.4 Flowchart of upstream tracing process

5.3.2 *The Effect of Automated Switches*

After a fault is cleared, the system needs to be reconfigured to isolate the fault and restore power for certain customers. This reconfiguration is performed by sectionalizing devices, most of which are manually operated. Thus, the customers have to wait for a crew to drive to the location and manually switch these devices on or off for system reconfiguration. In order to enhance reliability and improve customer satisfaction, electric utilities have begun to install automated switching systems in the distribution systems.

Automated switching systems are usually composed of several automated switches with the capability to cut fault current. These switches “talk” with one another to determine the status of the area they cover. The selection of the location of an automated switch should guarantee that the adjacent feeders have sufficient capacity to pick up all of the loads to which the other feeders need to transfer.

Figure 5.5 shows a sample system that consists of three substations supply three feeders in an urban area. Six automated switchers are installed along the feeders and at tie points between two adjacent feeders. If a fault occurs between substation 1 and switch 1, automated switch 1 will switch off and “tell” automated switch 2 that there is fault between substation 1 and automated switch 1. Then, after automated switch 2 receives the information and makes sure that automated switch 1 has isolated the fault, it will close and transfer the load between switch 1 and switch 2 to automated switch 3. At that point, the load between the two automated switches will feel no impact on their

SAIFI and SAIDI. (It is assumed that the automated switch isolates the fault and reconfigures the network immediately. The customer does not see the interruption.)

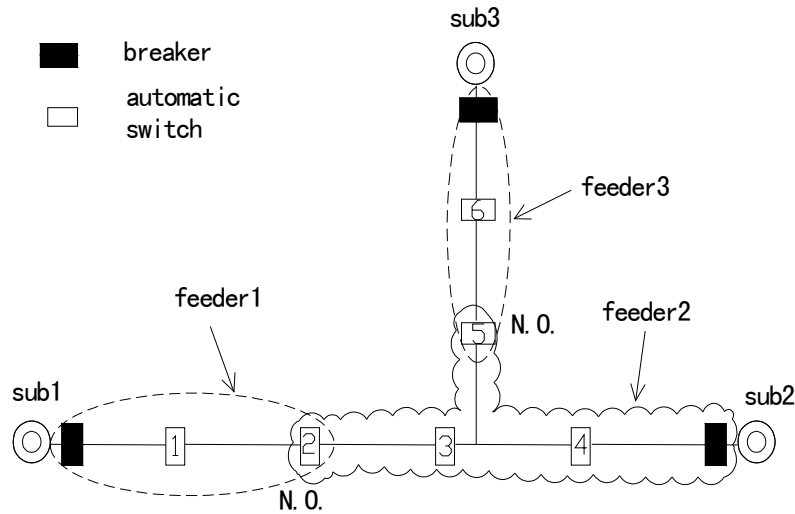

Figure 5.5 Example of a distribution system

In our simulation, we perform this function by dividing the whole system into several groups based on the location of the automated switch. If any fault occurs in a group, we use the upstream tracing method described in subsection A of this section to find a switch or fuse contained within this group. That is to say, after the automated switching system is installed, a fault will only affect the customers in this group unless the switching system fails or the adjacent feeders cannot pick up the transferred load. If the whole automatic switching system does not work, the three feeders will be independent, and they will simply be divided into three groups according to the normal open points.

For example, suppose a fault happens between substation 1 and switch 1. If there is no automatic switching system, the breaker of substation 1 will trip and all the

customers of feeder 1 will lose power for a certain amount of time, including the customers between switch 1 and switch 2. With automatic switching, as mentioned above, only the customers between substation 1 and switch 1 will lose power, and the customers between switch 1 and switch 2 will be transferred to substation 2 after automated switch 2 closes.

5.4 Result and Analysis

A program package has been developed to simulate the performance of a complex radial distribution system using the sequential Monte Carlo simulation. Exponential distributions are used to model the components by the rates of failure and repair, and by switching times.

This package obtains system topological data from an existing utility database and assigns user-specified default values to all component reliability data.

Reliability results can then be obtained on a system level, a feeder level, a customer level, or for any user-specified set of customers, respectively. These results can be displayed numerically and graphically.

5.4.1 The SAIFI and SAIDI without Automated Switches

In order to check our Monte Carlo simulation model, we first calculate the SAIFI and SAIDI of these three feeders without automated switching and compare the results with the historical record. The SAIDI and SAIFI values for each feeder are calculated and listed in Table 5.2.

Table 5.2 Comparison of Historical Record with MCS Results

| | SAIFI | | SAIDI | |
|------------|--------|------|--------|-------|
| | Record | MCS | Record | MCS |
| Haskell | 1.80 | 1.87 | 140.7 | 142.3 |
| White Rock | 1.81 | 1.55 | 143.4 | 160.0 |
| Lawther | 1.43 | 1.13 | 124.9 | 125.8 |

From the results of Table 5.2, we can see that the SAIFI and SAIDI calculated by the Monte Carlo simulation match quite well with the historical record.

The customers of a feeder have different SAIFI and SAIDI due to their different configurations and load demands. We calculate the SAIDI and SAIFI of different customers in Haskell #1, and the results are shown in Figures 5.6 and 5.7.

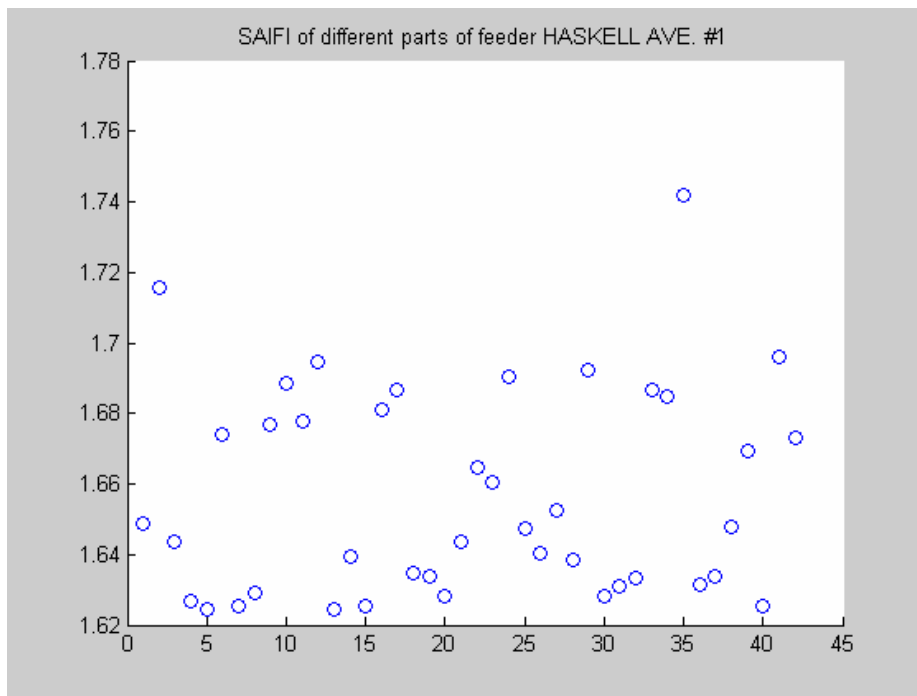

Figure 5.6 SAIFI of Different Customers on Haskell #1

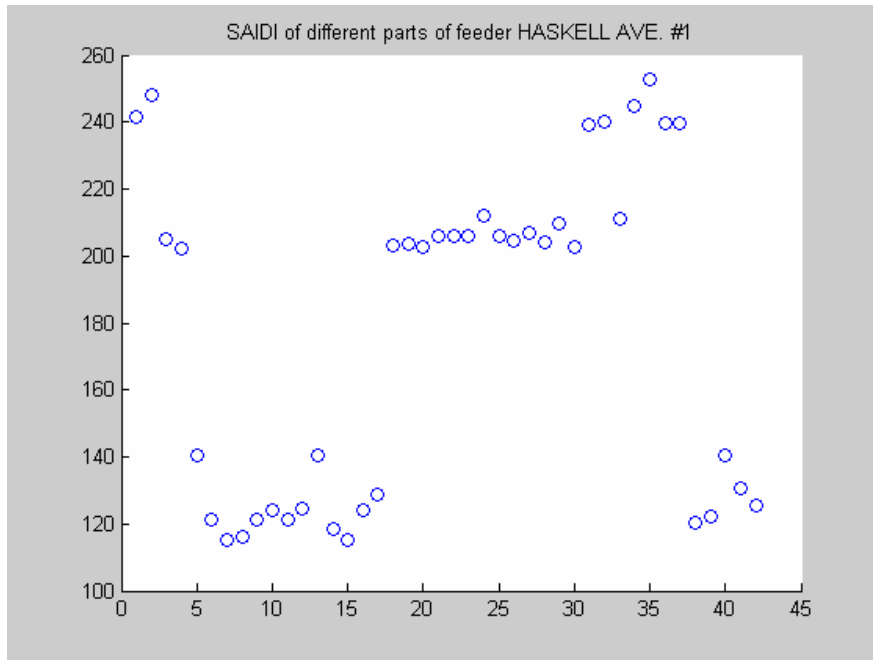

Figure 5.7 SAIDI of Different Customers on Haskell #1

From Figure 5.6 and 5.7, we know that the different customers' SAIFIs and SAIDIs are different. Through these figures, we could find the weak points in the feeders and find the optimal location to install automated switches.

5.4.2 The SAIFI and SAIDI with Automated Switches

In order to investigate the effects of an automatic switching system, we also simulated the system with six automated switches, and the results are shown in Table 5.3.

Table 5.3 Comparison of Effect of Automated Switches

| | SAIFI | | SAIDI (min) | |
|------------|--------|---------|-------------|---------|
| | W/O AS | With AS | W/O AS | With AS |
| Haskell | 1.87 | 0.61 | 142.3 | 59.2 |
| White Rock | 1.55 | 0.72 | 160.0 | 90.6 |
| Lawther | 1.13 | 0.67 | 125.8 | 76.9 |

From the table 5.3, we can see that the automated switches could improve the system's reliability considerably. For example, The SAIFI and SAIDI of Haskell decrease from 1.87 and 142.3 to 0.61 and 59.2 respectively.

5.4.3 The location of Automated Switches

If we move the location of the automated switch, the SAIFI and SAIDI of the feeder will also change. The impact on the customers near the automated switch is very significant, so this program is also a useful tool to help planning engineers to decide the location of the automated switch.

Since different customers have different reliability levels, and the effects of automated switches on different customers are also different. In particular, those customers who are near automated switch. For example, as shown in Figure 5.8, the installation of two automated switches has improved the SAIFI and SAIDI of this feeder from 1.55 min and 160 min to 0.681 and 83.7, respectively. But as shown in the figure, the SAIFI and SAIDI of customers near the automated switch (indicated in the circle) is still too high. We find that after we move the automatic switch to position 2 the SAIFI and SAIDI will decrease from 0.681 min and 83.7 min to 0.529 and 64.6, respectively. Definitely the SAIFI and SAIDI in the green area will increase a little. But the SAIFI and SAIDI here is quite low, so the effect is insignificant. The effect of change is shown in Table 5.4.

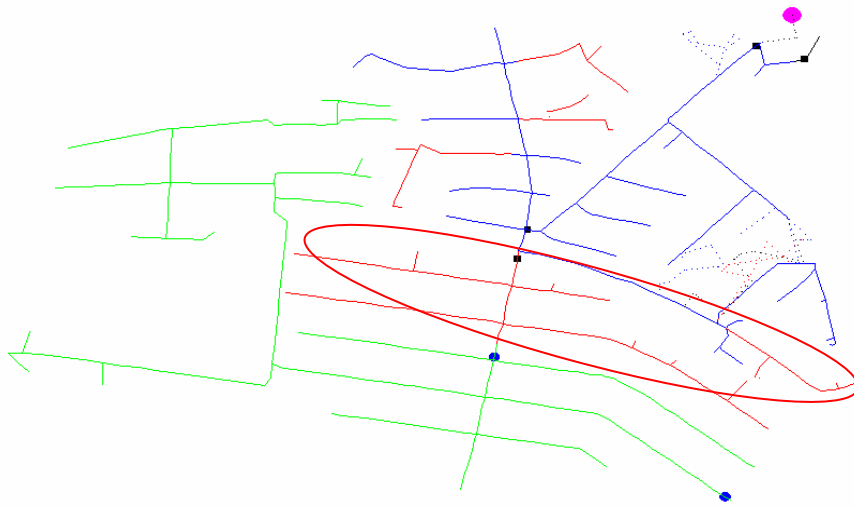

Figure 5.8 The SAIFI distribution of different customers

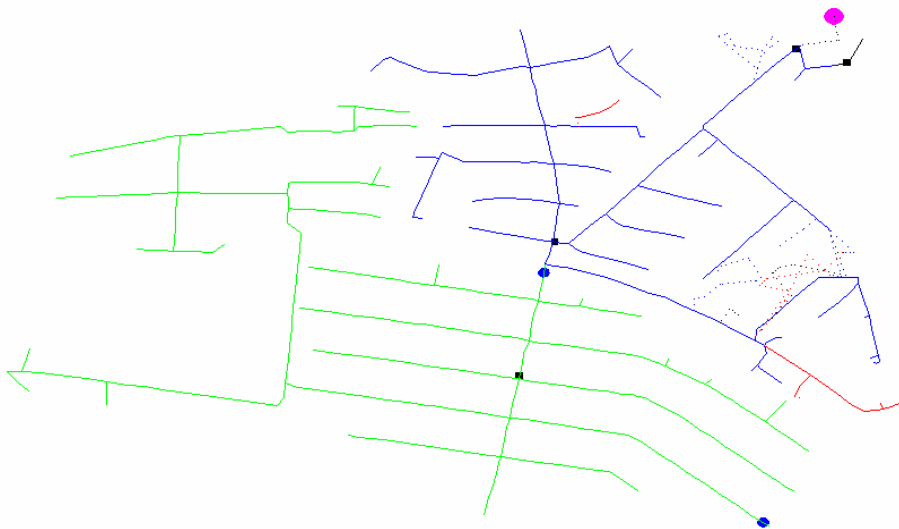

Figure 5.9 The SAIDI distribution of different customers

Table 5.4 Comparison of different location of automated switch

| | SAIFI | | SAIDI | |
|---------|------------|------------|------------|------------|
| | Position 1 | Position 2 | Position 1 | Position 2 |
| Lawther | 0.681 | 0.529 | 83.7 | 64.6 |
| Zone 7 | 0.89 | 0.10 | 125.0 | 9.0 |
| Zone 27 | 0.62 | 0.13 | 129.0 | 13.0 |
| Zone 28 | 0.97 | 0.20 | 136.0 | 21.0 |
| Zone 31 | 0.89 | 0.11 | 127.0 | 11.0 |
| Zone 32 | 0.93 | 0.14 | 0.14 | 14.0 |

CHAPTER 6

DISTRIBUTED COMPUTATION

6.1 The Concept of Distributed Computation

Distributed computing, an outcome of the development of computer networks, is a programming paradigm focusing on designing distributed, open, scalable, transparent, and fault-tolerant systems. Usually, distributed computing is applied to accomplish a huge and time-consuming project by dividing the larger project into smaller tasks and submitting them to a computer cluster consisting of many computers. Faster response can thus be achieved without super computers.

6.2 Applying Distributed Computation with Matlab

The Matlab Distributed Computing Toolbox (MDCT) and the Matlab Distributed Computing Engine (MDCE) enable us to coordinate and execute independent Matlab operations simultaneously on a cluster of computers, speeding up execution of large Matlab jobs.

The first step is setting up the distributed computing architecture with Matlab using MDCT and MDCE. The Matlab “client” is the MDCT–installed computer in which the job is located. The “job manager” is the computer that administers and coordinates the execution of jobs and the evaluation of their tasks. Matlab “workers” are

the MDCE–installed computers that together run the tasks distributed by the job manager.

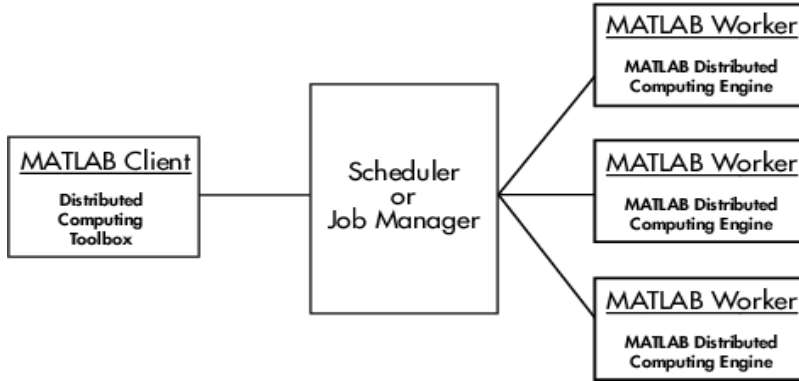

Figure 6.1 The basic distributed computing configuration

After the distributed computing cluster is set up, the job can be divided into several tasks and submitted to the job manager, which distributes the tasks among Matlab workers and conveys the final computing results to the Matlab client, where the job is placed after every task is done.

The distributed computing for power system blackout saves the CPU time almost 60% (see the Table 6.1).

Table 6.1 CPU time saved for power system blackout by distributed computation

| | Converged Mean Time (days) | CPU Time (s) |
|-----------------------|-------------------------------|-----------------|
| Normal Simulation | 53.7764 | 4395.2 |
| Distributed Computing | 52.9604 | 1488.2 |

The distributed computing for distribution system reliability saves the CPU time almost 55% (see the following table).

Table 6.2 CPU time saved for distribution system reliability by distributed computation

| | SAIFI | SAIDI | CPU Time (s) |
|-----------------------|-------|-------|--------------|
| Normal Simulation | 0.72 | 81.1 | 95.30 |
| Distributed Computing | 0.73 | 82.8 | 42.45 |

CHAPTER 7

SUMMARY AND CONCLUSIONS

7.1 Summary and Conclusions

In this dissertation, we use sequential Monte Carlo Simulation to study the power system blackout. A detailed description of power system models, including structure-preserving transient stability model, automatic generator control (AGC) model, are presented. In addition, a model of hidden failures and a normal reliability model are also described.

After the thorough analysis of blackout mechanism, we classify the factors that cause the blackout of power system into two types: deterministic factors and probabilistic factors. The effects of these two factors are different. The primary causes of blackouts are usually related to probabilistic factors. Deterministic factors and probabilistic factors combine to cause the cascading failures, which may cause the blackouts.

We investigate the general features of power system blackouts from the study of their mechanisms through the employment of statistical and probability theory. We classify the blackouts into different levels and find each level satisfies Gamma distribution. So the total power system blackout should satisfy mixture of Gamma distribution. The theoretical proofs are provided to justify the validity of the proposed

distribution and the numerical results are also given to prove the theory of power system blackouts proposed:

1. The distributions of power system blackout satisfy mixture of Gamma distribution.

The probability density function is:

$$f(x) = \sum_{k=1}^{\infty} p_k \text{Gamma}(x; k, \beta) \quad x \geq 0.$$

2. The shape parameter of Gamma distribution equals the level number of blackout.

The scale parameters are same for all Gamma distribution. It is only decided by the distribution of each element in the power system. So these Gamma distributions are uniquely decided by the probabilistic factors.

3. The physical properties (deterministic factors) of power system only affected the

distribution of p_k , where p_k satisfy $\sum_{k=1}^{\infty} p_k = 1$.

Monte Carlo simulation is a very flexible method to analyze power system reliability. In this dissertation, we also discuss how to evaluate the reliability of distribution system by using Monte Carlo simulation. A relation function is defined to model the radial distribution system. The results of a practical distribution system are compared in both the historical record and Monte Carlo simulation techniques. Our procedure is relatively simple and requires a relatively small amount of computer time. Reliability indices calculated by a series of trials and indices on the whole system as well as possible load points were obtained, which cannot be provided by analytical techniques.

In order to reduce the simulation time, distributed computing with Matlab is used.

7.2 Recommendation for Further Research

Although our Monte Carlo simulation has included detailed model of power system, if we want it to be widely used in larger and practical system, we still need some work to do:

Our research is about analysis of power system blackout. It dose not suggest any measures to prevent blackouts happen. In ref [56-59], some control strategies, such as islanding, are taken to prevent blackouts. We could also simulate these strategies in our MCS model.

The main disadvantage of sequential MCS is its huge computation time, especially for Time Domain Simulation. In recent years, direct methods are introduced to analyze the stability of power system [60, 61]. This method could save a lot of computation time. In our MCS model, we could use direct method instead of time domain simulation. It will reduce computation time a lot.

In our simulation, if any bus voltage is bigger than 1.25 or lower than 0.7, we will consider voltage collapse and blackout happens. But we didn't use reactive optimization. We simplify the problem by assume each generator unit as a PV bus. Sometimes it is difficult for a larger system power flow to converge. It is better to add reactive optimization in our MCS model for large system.

Our distributed computation only uses one master station and three slave station to perform parallel computation. In order to run the program efficiently, more slave stations are needed.

REFERENCES

- [1] Energy Policy Act of 1992. October 5. Public Law – 102-486, 102nd Congress.
- [2] A.P. Meliopoulos, “Analytical Techniques for Bulk Power System Reliability Assessment” IEEE Tutorial Course Electric Delivery System Reliability Evaluation, 2005.
- [3] Viktor A.Levi, Jovan M. Nahman, Dusko P. Nedic, “Security Modeling for Power System Reliability Evaluation” IEEE Transactions on Power Systems, Vol.16, No. 1, pp. 29-37, Feb. 2001.
- [4] Xiaochuan Luo, Chanan Singh, Alton D. Patton, “Power System Reliability Evaluation Using Learning Vector Quantization and Monte Carlo Simulation”, Electric Power Systems Research, Vol. 66, No 2, p. 163-169, Aug 2003
- [5] Massoud Amin, Phillip F.Schewe, “Preventing Blackouts”, Scientific American Magazine, May 2007, pp 60-61.
- [6] D.N. Kosterev, C.W. Taylor, and W.A. Mittelstadt, "Model Validation for the August 10, 1996 WSCC System Outage," *IEEE Trans. on Power System*, Vol. 14, pp. 967–979, Aug. 1999.
- [7] “Final Report, August 10, 1996 Event,” West Systems Coordinating Council, Oct. 1996.
- [8] Massoud Amin, Phillip F.Schewe, “Preventing Blackouts”, Scientific American Magazine, May 2007, pp 60-61.
- [9] U.S.-Canada Power System Outage Task Force, “Causes of the August 14th Blackout,” Nov. 2003
- [10] L. Milli, Q. Qiu, A.G. Phadke, “Risk Assessment of Catastrophic Failures in Electric Power Systems”, *Int. J. Critical Infrastructures*, Vol.1, No.1, pp38-63, 2004

- [11] Shijie Deng, Sakis Meliopoulos, Tim Mount, etc “Modeling Market Signals for Transmission Adequacy Issues: Valuation of Transmission Facilities and Load Participation Contracts in Restructured Electric Power Systems”, Power Systems Engineering Research Center, Feb 2007, pp 1.
- [12] Bei Gou, Hui Zheng, Weibiao Wu, and Xingbin Yu, “Investigating the Probability Distribution of Power system Blackouts—Part I: Mechanism and Theory,” submitted to IEEE Transactions on Power Systems.
- [13] S. Tamronglak, S.H. Horowitz, A.G. Phadke, and J.S. Thorp, “Anatomy of Power System Blackouts: Preventive Relaying Strategies,” IEEE Trans. on Power Systems, Vol. 11, No. 2, April 1996, pp. 708–715.
- [14] S. Tamronglak, “Analysis of Power System Disturbances Due to Relay Hidden Failures,” Ph.D. Dissertation, Virginia Polytechnic and State University, Blacksburg, Virginia, March 1994.
- [15] J. De La Ree et al., “Catastrophic Failures in Power Systems: Causes, Analyses, and Countermeasures,” Proc. IEEE, Vol. 93, No. 5, May 2005.
- [16] D. S. Kirschen, “Power System Security,” Power Engineering Journal, Oct. 2002.
- [17] A..G. Phadke and J.S. Thorp, “Expose Hidden Failures to Prevent Cascading Outages,” IEEE Comput. Appl. Power, Vol. 9, July 1996, pp. 20–23.
- [18] S. Tamronglak et al., “Anatomy of Power System Blackouts: Preventive Relay Strategies,” IEEE Trans. Power Delivery, Vol. 11, Apr. 1996, pp. 708–715.
- [19] D. C. Elizondo and J. De La Ree, “Analysis of Hidden Failures of Protection Schemes in Large Interconnected Power Systems,” IEEE PES General Meeting, June 2004, pp. 107–114.
- [20] D.C. Elizondo, J. De La Ree, A.G. Phadke, and S.H. Horowitz, “Hidden Failures in Protection Systems and Their Impact on Wide-area Disturbances,” presented at the IEEE Power Engineering Soc. Winter Meeting, Columbus, OH, 2001.
- [21] K. Bae and J.S. thorp, “An Importance Sampling Application: 179-bus WSCC System Under Voltage Based Hidden Failures and Relay Misoperation,” Proc. 1998 System Science 31st Hawaii Int. Conf., Vol. 3, pp. 39–46

- [22] PJM J. Chen and J.S. Thorp, "A Reliability Study of Transmission System Protection via a Hidden Failure DC Load Model," Power System Management and Control, April 2002 Conference No. 488 @ IEE 2002, pp. 17–19.
- [23] Xingbin Yu and C. Singh, "A Practical Approach for Integrated Power System Vulnerability Analysis with Protection Failures," IEEE Trans. Power Sys., Vol. 19, Nov. 2004, pp. 1811–1820.
- [24] C. Singh, Joydeep Mitra, "Monte Carlo Simulation for Reliability Analysis of Emergency and Standby Power Systems" Industry Applications Conference, Vol. 3, Oct. 1995, pp. 2290–2295.
- [25] Bei Gou, Hui Zheng, Weibiao wu, Xingbin Yu, "Probability Distribution of Power System Blackouts" Power engineering society general Meeting, June 2007 pp1-8.
- [26] P. Crucitti, V.Latora, M. Marchiori, "Model for Cascading Failures in Complex Networks," Phys. Rev. E, Vol 69, 045104, 2004.
- [27] A. E. Motter, Y.C. Lai, "Cascade-based attacks on Complex Networks," Phys. Rev. E, Vol 66, 065102, 2002.
- [28] X.F. Wang, J.Xu, "Cascading Failures in Coupled Map Lattices," Phys. Rev. E, Vol 70, 056113, 2004.
- [29] B.A. Carreras, D.E. Newman, I. Dobson, A.B. Poole, "Evidence for Self-organized Criticality in a Time Series of Electric Power System Blackouts." IEEE Transactions on Circuits and Systems I, vol 51, no 9, Sept. 2004, pp 1733-1740.
- [30] H. J. Jensen, "Self-Organized Criticality." Cambridge University Press, 1998, ISBN: 0 521 48371 9.
- [31] Bei Gou, Hui Zheng, Weibiao Wu, Xingbin Xu, "Probability Distribution of Blackouts in complex Power Networks," Circuits and Systems, 2007. ISCAS 2007. IEEE International Symposium on 27-30 May 2007 pp69 – 72.
- [32] Bei Gou, Hui Zheng, Weibiao Wu, Xingbin Xu, "The Statistical Law of Power System Blackouts," NAPS 2006, 38th North American, Sept. 2006, pp495-501.

- [33] Alvvro Giuso, Romeo Ortega, Alexander Standkovic, "On Transient Stabilization of Power Systems: A Power-Shaping solution for Structure-Preserving Models," Proceedings of the 45th IEEE Conference on Decision & Control, December 2006.
- [34] Byongjun Lee, Venkataramana Ajjarapu, "Factors to Be Considered in the Study of Voltage Stability of Structure Preserving Power System Model," Circuits and Systems, 1993., Proceedings of the 36th Midwest Symposium on 16-18 Aug. 1993 Page(s):700 - 703 vol.1.
- [35] F. Milano, Documentation for PSAT version, Chap 8, July 2005, pp.71-74.
- [36] Allen J. wood, Bruce F. Wollenberg, *Power Generation Operation and Control*, New York: John Wiley & Sons, 1996, p. 352.
- [37] P. Kundur, *Power System Stability and Control*, New York: Mc-Graw-Hill, 1994, p. 813.
- [38] EPRI, Workshop Proceedings: Power System Planning and Engineering –Research Needs and Priorities, Report EL-6503, Oct. 1989
- [39] A.Breipohl, F.N.Lee, J.Huang, Q.Feng, "Sample Size Reduction in Stochastic Production Simulation," *IEEE/PES 1990 Winter Meeting, Paper 90 WM 122-2 PWRS*, Feb. 1990.
- [40] J.Kleijnen, *Statistical Techniques in Simulation – Part I*, Marcel Dekker, New York, 1974.
- [41] M.Pereira, M.Maceira, G.Oliveira, L.Pinto, "Combining Analytical Models and Monte-Carlo Techniques in Probabilistic Power System Analysis," *IEEE Trans.on Power System*, Vol. 7, No. 1, pp.265-272, Feb. 1992.
- [42] A.Melo, M.Pereira, A.da Silva, "Frequency and Duration Calculations in Composite Generation and Transmission Reliability Evaluation," *IEEE Trans.on Power System*, Vol. 7, No. 1, pp.265-272, Feb. 1992.
- [43] R.E. Brown, *Electric Power Distribution Reliability*. Marcel Dekker, Inc., New York, 2002.
- [44] R.E. Brown, "Distribution System Reliability: Analytical and Empirical Techniques," IEEE Power Engineering Society General Meeting, 2005.

- [45] J. N. Balijepalli, S. S. Venkata, R. D. Christie, "Modeling and Analysis of Distribution Reliability Indices," IEEE Trans. Power Delivery, Vol. 19, No. 4, Oct, 2004.
- [46] J.A. Momoh, "Value-based Distribution System Reliability Analysis," 1997 IEEE SMC 0-7803-4053-4, pp. 3452–3457.
- [47] J. J. Chen and S. Chang "A Neural Network Approach to Evaluate Distribution System Reliability," Systems Engineering, 1992.
- [48] R. Billinton and R.N. Alan, Reliability Evaluation of Engineering Systems, 2nd Edition, Plenum Press, New York, 1994.
- [49] R. Billinton and P. Wang, "Teaching Distribution System Reliability Evaluation Using Monte Carlo Simulation," IEEE Trans. on Power Systems, Vol. 14, No. 2, May 1999.
- [50] J R.E. Brown, "Distribution System Reliability Assessment Using Hierarchical Markov Modeling," IEEE Trans. on Power Delivery, Vol. 11, No. 4, Oct. 1996.
- [51] R. Billinton and Rajesh Karki, "Application of Monte Carlo Simulation to Generating System Well-being Analysis," IEEE Trans. on Power Systems, Vol. 14, No. 3, Aug. 1999.
- [52] R.E. Brown, "Distribution System Reliability: Analytical and Empirical Techniques," IEEE Power Engineering Society General Meeting, 2005.
- [53] R.H. Stillman, "Modeling Failure Data of Overhead Distribution System," IEEE Trans. on Power Delivery, Vol. 15, No. 4, Oct. 2000.
- [54] S. Asgarpoor M.J. Mathine, "Reliability Evaluation of Distribution Systems with Non-exponential Down Times," IEEE Trans. on Power System, Vol. 12, No. 2, May 1997.
- [55] W.E. Khattam Y.G. Hegazy M.M.A. Salama, "Investigating Distributed Generation Systems Performance Using Monte Carlo Simulation," IEEE Trans. on Power System, Vol. 21, No. 2, May 2006.
- [56] S.S.Ahmed, N.C.Sarker, A.B.Khairuddin, etc, "A Scheme for Controlled Islanding to Prevent Subsequent Blackout", IEEE Trans. on Power System Vol. 18, No1, Feb. 2003, pp136-143.

- [57] Haibo You, Vijay Vittal, "Self-Healing in Power System: An Approach Using Islanding and Rate of Frequency Decline-based Load Shedding", IEEE Trans. on Power System Vol. 18, No1, Feb. 2003, pp174-181.
- [58] Haibo You, Vijay Vittal, "Slow Coherency-Based Islanding", IEEE Trans. on Power System Vol. 9, No3, Aug 1994, pp1194-1208.
- [59] Bo Yang, Vijay Vittal, "Slow-Coherency-Based Controlled Islanding-A Demonstration of the Approach on the August 14, 2003 Blackout Scenario". IEEE Trans on Power Systems, Vol. 21, No.4, Nov. 2006, pp 1840~1847
- [60] Hsiao-Dong Chiang, F.F Wu, P.P. Varaiya, "A BCU method for direct analysis of power system transient stability", IEEE Trans. on Power System Vol. 9, No3, Aug 1994, pp1194-1208.
- [61] Y.S.Xue, T.V. Cutsem, R.M. Pavella, "A Simple Direct Method for Fast Transient Stability Assessment of Large Power Systems". IEEE Trans on Power Systems, 1998, Vol. 9, No.2, pp 400~412

BIOGRAPHICAL INFORMATION

Hui Zheng received Bachelor's and Master's degrees in Electrical Engineering department from Shanghai Jiaotong University, Shanghai, China, in 1992 and 1997. His employment experience includes being a Assistant Engineer in Hefei (China) Power Supply Bureau in Anhui Province during 1992-1994 and an Engineer in East China Electric Power Design Institute (ECEPDI) in Shanghai during 1997-2004. His areas of interest are power system transient stability analysis, power system reliability, unit commitment, power deregulation, and power system operation.